

ISO/~~XX~~FDIS 7972:2023(E)

ISO TC61/SC 11/WG 5

Secretariat: JISC

Date: ~~2022-12-23~~2023-02-06

Adhesives — Absorption of water into an adhesive layer using an open-faced specimen and determination of shear strength by secondary bonding

iTeh STANDARD PREVIEW (standards.iteh.ai)

ISO/FDIS 7972

<https://standards.iteh.ai/catalog/standards/sist/f96dfd23-0bf6-4f8c-b6ad-8365ca398071/iso-fdis-7972>

© ISO ~~2022~~2023

All rights reserved. Unless otherwise specified, or required in the context of its implementation, no part of this publication may be reproduced or utilized otherwise in any form or by any means, electronic or mechanical, including photocopying, or posting on the internet or an intranet, without prior written permission. Permission can be requested from either ISO at the address below or ISO's member body in the country of the requester.

ISO copyright office

CP 401 • Ch. de Blandonnet 8

CH-1214 Vernier, Geneva

Phone: +41 22 749 01 11

Email: copyright@iso.org

Website: www.iso.org~~www.iso.org~~

Published in Switzerland

iTeh STANDARD PREVIEW (standards.iteh.ai)

ISO/FDIS 7972

<https://standards.iteh.ai/catalog/standards/sist/f96dfd23-0bf6-4f8c-b6ad-8365ca398071/iso-fdis-7972>

Contents

Foreword	Error! Bookmark not defined.
Introduction	Error! Bookmark not defined.
1 Scope	Error! Bookmark not defined.
2 Normative references	Error! Bookmark not defined.
3 Terms and definitions	Error! Bookmark not defined.
4 Principle	Error! Bookmark not defined.
5 Apparatus	Error! Bookmark not defined.
5.1 Linear measuring device	Error! Bookmark not defined.
5.2 Beakers, enclosures, the thermometer, and the ventilated ovens	Error! Bookmark not defined.
5.3 Tensile-testing machine	Error! Bookmark not defined.
6 Test specimens	Error! Bookmark not defined.
6.1 Open-faced specimen	Error! Bookmark not defined.
6.1.1 Dimension and deposition	Error! Bookmark not defined.
6.1.2 Layer thickness	Error! Bookmark not defined.
6.1.3 Surface treatment	Error! Bookmark not defined.
6.1.4 Cleaning and immersion in water	Error! Bookmark not defined.
6.2 Specimen for single lap shear test	Error! Bookmark not defined.
6.2.1 Dimensions and alignment	Error! Bookmark not defined.
6.2.2 Number of specimens	Error! Bookmark not defined.
6.3 Accuracy	Error! Bookmark not defined.
7 Conditioning of test	Error! Bookmark not defined.
8 Procedure	Error! Bookmark not defined.
8.1 Immersion in water	Error! Bookmark not defined.
8.2 Secondary bonding	Error! Bookmark not defined.
8.3 The tensile shear test	Error! Bookmark not defined.
9 Precision data	Error! Bookmark not defined.
10 Calculation and expression of results	Error! Bookmark not defined.
11 Test report	Error! Bookmark not defined.
Foreword	iv
Introduction	v
1 Scope	1
2 Normative references	1
3 Terms and definitions	1
4 Principle	2
5 Apparatus	2
6 Test specimens	2
6.1 Open-faced specimen	2

6.1.1	Cleaning	2
6.1.2	Surface treatment	3
6.1.3	Deposition and control of the adhesive thickness	3
6.1.4	Immersion in water	3
6.2	Specimen for single lap shear test	4
6.2.1	Dimensions and alignment	4
6.2.2	Number of specimens	4
6.3	Accuracy	4
7	Conditioning of test	5
8	Procedure	5
8.1	Immersion in water	5
8.2	Secondary bonding	5
8.3	Tensile shear test	5
9	Precision data	5
10	Calculation and expression of results	6
11	Test report	6
Annex A (informative) Example of preparation of open-faced specimen		7
Annex B (informative) Example of secondary bonding		10
Bibliography		14

iTeh STANDARD PREVIEW
(standards.iteh.ai)

[ISO/FDIS 7972](https://standards.iteh.ai/catalog/standards/sist/f96dfd23-0bf6-4f8c-b6ad-8365ca398071/iso-fdis-7972)

<https://standards.iteh.ai/catalog/standards/sist/f96dfd23-0bf6-4f8c-b6ad-8365ca398071/iso-fdis-7972>

Foreword

ISO (the International Organization for Standardization) is a worldwide federation of national standards bodies (ISO member bodies). The work of preparing International Standards is normally carried out through ISO technical committees. Each member body interested in a subject for which a technical committee has been established has the right to be represented on that committee. International organizations, governmental and non-governmental, in liaison with ISO, also take part in the work. ISO collaborates closely with the International Electrotechnical Commission (IEC) on all matters of electrotechnical standardization.

The procedures used to develop this document and those intended for its further maintenance are described in the ISO/IEC Directives, Part 1. In particular, the different approval criteria needed for the different types of ISO documents should be noted. This document was drafted in accordance with the editorial rules of the ISO/IEC Directives, Part 2 (see www.iso.org/directives).

Attention is drawn to the possibility that some of the elements of this document may be the subject of patent rights. ISO shall not be held responsible for identifying any or all such patent rights. Details of any patent rights identified during the development of the document will be in the Introduction and/or on the ISO list of patent declarations received (see www.iso.org/patents).

Any trade name used in this document is information given for the convenience of users and does not constitute an endorsement.

For an explanation of the voluntary nature of standards, the meaning of ISO specific terms and expressions related to conformity assessment, as well as information about ISO's adherence to the World Trade Organization (WTO) principles in the Technical Barriers to Trade (TBT), see www.iso.org/iso/foreword.html.

This document was prepared by Technical Committee ISO/TC 61, *Plastics*, Subcommittee SC 11, *Products*.

Any feedback or questions on this document should be directed to the user's national standards body. A complete listing of these bodies can be found at www.iso.org/members.html.

Introduction

Adhesives absorb moisture from the environment over a long period of time. The absorbed water often decreases the strength of the adhesive. Therefore, it is important to evaluate the effect of absorbed water properly to ensure the durability of adhesive bonding joints. Such an evaluation is generally time-consuming because the penetration of water into the adhesive layer is a slow process. Additionally, ~~over time~~, the moisture in the adhesive layer can alter the chemical and physical properties of the adhesive layer and interface over time.

iTeh STANDARD PREVIEW
(standards.iteh.ai)

ISO/FDIS 7972

<https://standards.iteh.ai/catalog/standards/sist/f96dfd23-0bf6-4f8c-b6ad-8365ca398071/iso-fdis-7972>

Adhesives — Absorption of water into an adhesive layer using an open-faced specimen and determination of shear strength by secondary bonding

1 Scope

This document specifies a method for the rapid permeation of water to an adhesive layer using a specimen with one side open, the secondary bonding the specimens with the adhesive layer that is still moistened, and a shear strength test of the secondary bonded specimen, for the selection of water-resistant adhesives and the determination of suitable surface treatments. It does not assess the water resistance of the actual joint itself, as the distribution of water in the adhesive layer is different. This test procedure does not provide design information.

2 Normative references

The following documents are referred to in the text in such a way that some or all of their content constitutes requirements of this document. For dated references, only the edition cited applies. For undated references, the latest edition of the referenced document (including any amendments) applies.

ISO 175, *Plastics — Methods of test for the determination of the effects of immersion in liquid chemicals*

ISO 291, *Plastics — Standard atmospheres for conditioning and testing*

ISO 472, *Plastics — Vocabulary*

ISO 4587, *Adhesives — Determination of tensile lap-shear strength of rigid-to-rigid bonded assemblies*

~~ISO 4588, *Adhesives — Guidelines for the surface preparation of metals*~~

ISO 10365, *Adhesives — Designation of main failure patterns*

~~ISO 13895, *Adhesives — Guidelines for the surface preparation of plastics*~~

3 Terms and definitions

For the purposes of this document, the terms and definitions given in ISO 472 and the following apply.

ISO and IEC maintain terminological databases for use in standardization at the following addresses:

— ISO Online browsing platform: available at <https://www.iso.org/obp>

— IEC Electropedia: available at <https://www.electropedia.org/>

3.1 open-faced specimen

specimen with an adhesive layer on an adherend, such that one side of the adhesive layer is not in contact with the adherend and is open

3.2

primary adhesive

adhesive used to prepare an open-faced specimen

3.3

secondary adhesive

adhesive for adhering open-faced specimens together

4 Principle

The adhesive layers of the open-faced specimens are completely immersed in water. The water permeates through the open surface of adhesive layer in the specimen consequently shortening the time required to saturate the adhesive layer with water, in comparison to a usual specimen. Two open-faced specimens are joined with a secondary adhesive to prepare a specimen for the lap-shear test. The test specimen is prepared quickly while the adhesive layer is still wet using secondary adhesives. The characteristic of the secondary bonding adhesive shall be that it hardens within 24 hours without heating (ambient temperature). The adhesive lap-shear bond strength is determined by stressing a single-overlap joint in shear by applying a tensile force parallel to the bond area along the major axis of the specimen. Drying is avoided by completing the strength test within one day of the secondary bonding process. This enables the evaluation of strength while the adhesive layer is wet.

NOTE Single-lap specimens are economical, practical, and easy to fabricate. They are the most widely used for the development, evaluation, and comparative study of adhesives and bonded products, including manufacturing quality control.

5 Apparatus

standards.iteh.ai/catalog/standards/sist/f96dfd23-0bf6-4f8c-b6ad-8365ca398071/iso-fdis-7972

5.1 Linear measuring device, such as vernier callipers or a micrometre, capable of measuring the width and thickness of the specimen with an accuracy of at least 0,01 mm, should be used.

5.2 Beakers, enclosures, the thermometer, and the ventilated ovens, used shall be in accordance with ISO 175.

5.3 Tensile-testing machine, which shall be in accordance with ISO 4587.

6 Test specimens

6.1 Open-faced specimen

NOTE See Annex A.

6.1.1 Cleaning

The open-faced specimen shall be constructed from a rigid adherend such as metals and hard plastics, with the dimensions shown in Figure 1. The surface of the adherend in the open-faced specimen should be clean. If not, it should be washed with a solvent, such as high-purity acetone. The surface of the primary adhesive layer should not be touched.

6.1.2 Surface treatment

The adherend surface should be treated properly to obtain an optimum bond. Surface treatments can be performed per the manufacturer's instructions or in accordance with ISO 4588 for metal and ISO 13895 for plastics.

6.1.3 Deposition and control of the adhesive thickness

The adhesive shall be sandwiched between an adherend and a flat plate. The surface of the flat plate shall be covered with a PTFE film or tape to prevent adhesion. The use of mould release agents, which can be contaminants, is not preferred. The flat plate should be larger than 15 mm × 25 mm. Subsequently, the specimen shall be clamped to maintain its state. The adhesive shall be cured per the recommendations of the adhesive manufacturer or the applicable material standard. The excess adhesive, squeezed out during curing, shall be removed, along with the clamp and cover. Special care shall be taken to prepare individual specimens that layer thicknesses are as uniform and as constant as possible. For example, thickness can be controlled by inserting small glass spheres into the primary adhesive. Depending on the purpose, the layer thickness and its accuracy can be changed. Unless otherwise specified, a typical thickness is 0,15 mm.

6.1.4 Immersion in water

The open-faced specimens shall be immersed in water for a specified duration and at a specific temperature, such that all the adhesive-covered tips are submerged in water completely.

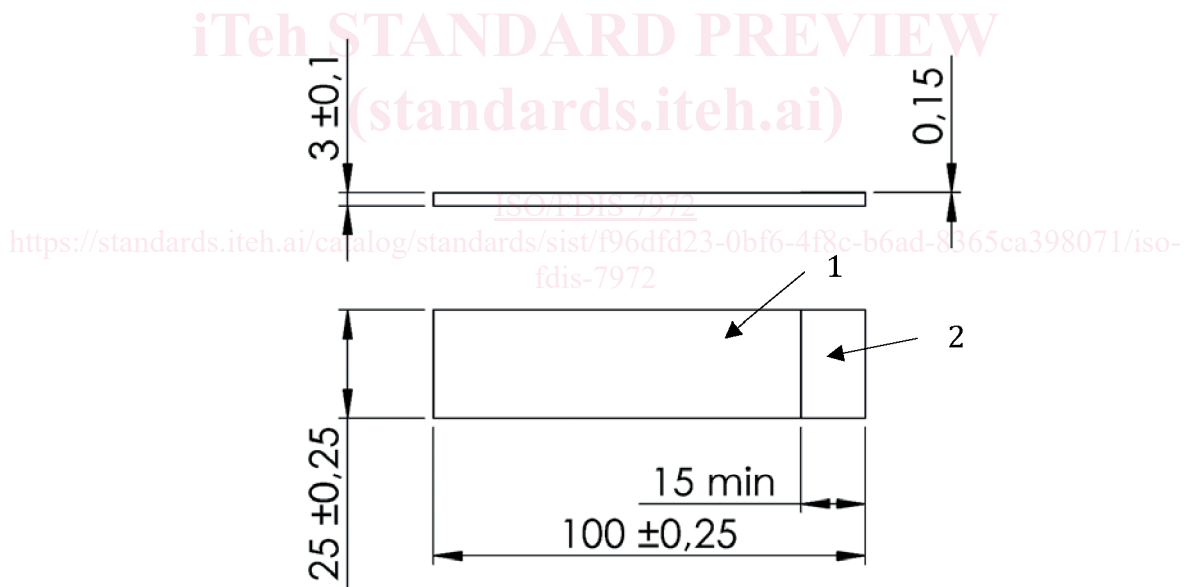

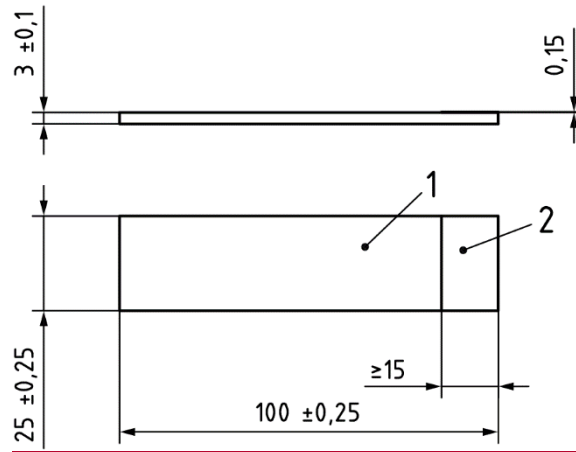

- Key**
- 1 rigid adherend
 - 2 primary adhesive layer

Figure 1 — Open-faced specimens

6.2 Specimen for single lap shear test

6.2.1 Dimensions and alignment

Test specimens for single lap shear test shall conform to the form, dimensions and alignment of the two open-faced specimens bonded together with secondary adhesives as shown in Figure 2. The length of overlap shall be 12,5 mm ± 0,25 mm. Special care shall be taken in preparing individual specimens to ensure proper alignment and that bond thicknesses are thin as possible as you can. Area held in grips is covered with tabs to apply force parallel to the adhesive surface.

6.2.2 Number of specimens

The number of specimens will depend on the precision required, but reliance should not be placed on fewer than five observations.

6.3 Accuracy

Measure the specimen dimensions to within ±0,01 mm.

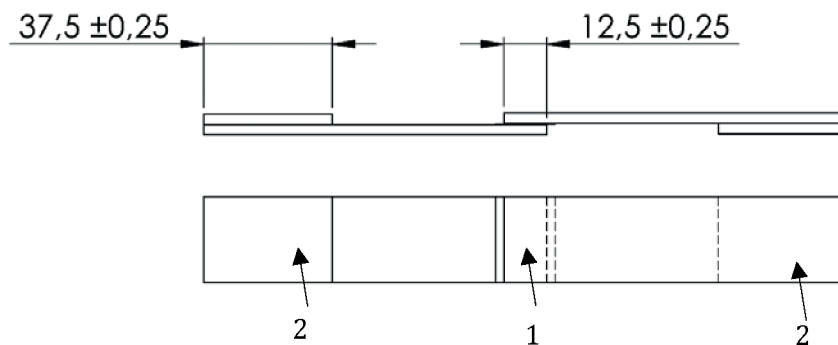

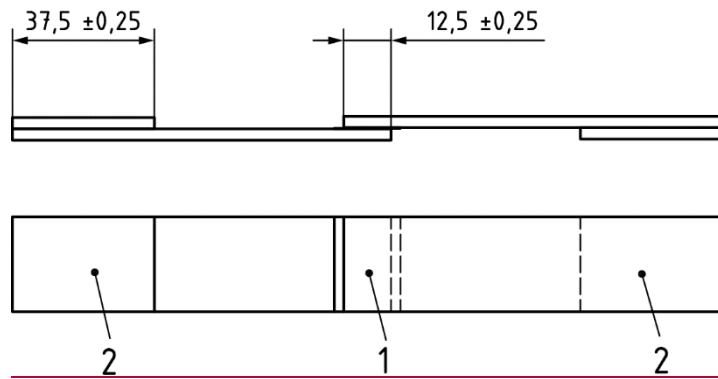
**Key**

- 1 area of secondary bond
- 2 area held in grips, tab

Figure 2 — Specimen for single lap shear test

7 Conditioning of test

The specimens shall be conditioned and tested in one of the standard conditioning atmospheres specified in ISO 291.

8 Procedure

8.1 Immersion in water

Immersion of the open-faced specimens in water shall be in accordance with ISO 175, except for the dimensions of the specimen. The immersion time and temperature can be arbitrarily set based on the characteristics of the adhesive. The water temperature shall be controlled at a constant temperature with a tolerance of ± 2 °C.

8.2 Secondary bonding

After removing the sample from the water and returning it to ambient temperature, 23 ± 1 °C. the excess water on the surface shall be gently wiped off with a filter paper or removed by short blowing air on it. Two open-faced specimens shall be immediately bonded with a secondary adhesive, such as cyanoacrylate. The curing time should follow the manufacturer's recommendations.

The tensile See Annex B.

8.3 Tensile shear test

The tensile shear test shall be performed in accordance with ISO 4587. The tensile test shall be completed within one day after the completion of the immersion. The fracture surface shall be observed after the tensile test. If it is broken by the secondary adhesive layer, the immersion conditions or secondary adhesive shall be changed. The appearance of a secondary adhesive layer on the fracture surface can be confirmed using surface analysis, such as ATR-FTIR.

9 Precision data

No relevant precision data are available at the time of publication.