

2023-04-27

ISO/~~DIS-PRF~~ 18279:2022(E)

ISO/TC 44/SC 13

Secretariat: DIN

Date: 2023-08-17

Brazing — Imperfections in brazed joints

Brasage fort — Défauts dans les assemblages réalisés par brasage fort

iTeh STANDARD PREVIEW

FDIS stage

ISO 18279

<https://standards.iteh.ai/catalog/standards/sist/e230c805-772f-44af-9cb2-79291098a086/iso-18279>

© ISO ~~2022~~2023

All rights reserved. Unless otherwise specified, or required in the context of its implementation, no part of this publication may be reproduced or utilized otherwise in any form or by any means, electronic or mechanical, including photocopying, or posting on the internet or an intranet, without prior written permission. Permission can be requested from either ISO at the address below or ISO's member body in the country of the requester.

ISO copyright office
CP 401 • Ch. de Blandonnet 8
CH-1214 Vernier, Geneva
Phone: + 41 22 749 01 11
~~Email~~E-mail: copyright@iso.org
Website: www.iso.org

Published in Switzerland

iTeh STANDARD PREVIEW (standards.iteh.ai)

ISO 18279

<https://standards.iteh.ai/catalog/standards/sist/e230c805-772f-44af-9cb2-79291098a086/iso-18279>

Contents

Foreword	iv
Introduction.....	v
1 Scope	1
2 Normative references.....	3
3 Terms and definitions	3
4 Symbols.....	3
5 Classification	4
5.1 General	4
5.2 External imperfections	5
5.3 Internal imperfections	5
Annex A (informative) Guidelines for practical evaluation of imperfections	13
Annex B (informative) Evaluation.....	14
Bibliography	19

iTeh STANDARD PREVIEW
(standards.iteh.ai)

ISO 18279

<https://standards.iteh.ai/catalog/standards/sist/e230c805-772f-44af-9cb2-79291098a086/iso-18279>

Foreword

ISO (the International Organization for Standardization) is a worldwide federation of national standards bodies (ISO member bodies). The work of preparing International Standards is normally carried out through ISO technical committees. Each member body interested in a subject for which a technical committee has been established has the right to be represented on that committee. International organizations, governmental and non-governmental, in liaison with ISO, also take part in the work. ISO collaborates closely with the International Electrotechnical Commission (IEC) on all matters of electrotechnical standardization.

The procedures used to develop this document and those intended for its further maintenance are described in the ISO/IEC Directives, Part 1. In particular, the different approval criteria needed for the different types of ISO documents should be noted. This document was drafted in accordance with the editorial rules of the ISO/IEC Directives, Part 2 (see www.iso.org/directives).

Attention is drawn to the possibility that some of the elements of this document may be the subject of patent rights. ISO shall not be held responsible for identifying any or all such patent rights. Details of any patent rights identified during the development of the document will be in the Introduction and/or on the ISO list of patent declarations received (see www.iso.org/patents).

Any trade name used in this document is information given for the convenience of users and does not constitute an endorsement.

For an explanation of the voluntary nature of standards, the meaning of ISO specific terms and expressions related to conformity assessment, as well as information about ISO's adherence to the World Trade Organization (WTO) principles in the Technical Barriers to Trade (TBT), see www.iso.org/iso/foreword.html.

This document was prepared by Technical Committee ISO/TC 44, *Welding and allied processes*, Subcommittee SC 13, *Brazing materials and processes*, in collaboration with the European Committee for Standardization (CEN) Technical Committee CEN/TC 121, *Welding and allied processes*, in accordance with the Agreement on technical cooperation between ISO and CEN (Vienna Agreement).

This second edition cancels and replaces the first edition (ISO 18279:2003), which has been technically revised.

The main changes are as follows:

- —An additional quality level for brazed joint imperfections has been added in [Annex B](#) in order to reflect the technical progress that has been achieved over the past decade as well as the need for increased requirements regarding reliability of brazed joints for critical applications. Quality levels have been reevaluated.

Any feedback or questions on this document should be directed to the user's national standards body. A complete listing of these bodies can be found at www.iso.org/members.html. Official interpretations of ISO/TC 44 documents, where they exist, are available from this page: <https://committee.iso.org/sites/tc44/home/interpretation.html>.

Introduction

Brazed joints usually contain imperfections of various types, some of which are detrimental in almost every case while others can be detrimental or harmless, depending entirely on the service requirements of the joint in question. Therefore, it is often necessary to classify the imperfections in a brazed joint and then try to assess the significance of their effects on the behaviour of the joint in service. The classification is relatively easy and [Table 1](#) describes the imperfections that most commonly occur. The assessment of significance is not easy (see also [Annex A](#)).

For welded joints, there has been extensive work carried out for many years on the significance of imperfections in service; however, such work has not been carried out on brazed joints. Moreover, the work on welded joints is only rarely relevant to brazed joints, mainly because of differences in geometry and stressing. Therefore, this document cannot give definitive quality levels for brazed joints. These can only be produced as experience is gained from industrial applications. However, [Annex B](#) gives some suggestions for quality levels for general applications, which [may](#) be of help where detailed information is not available. The use of quality levels can only be successful if the imperfections that are relevant to the application of the brazed joint are determined.

iTeh STANDARD PREVIEW
(standards.iteh.ai)

[ISO 18279](#)

<https://standards.iteh.ai/catalog/standards/sist/e230c805-772f-44af-9cb2-79291098a086/iso-18279>

Brazing — Imperfections in brazed joints

1 Scope

This document details a classification of imperfections that can occur in brazing joints. In addition, guidance is provided on quality levels and suggested limits for imperfections are detailed.

For requirements not covered by this document, reference can be made to other sources, [e.g. such as](#) statutory regulations, codes of practice and technical delivery conditions.

No information is given on how imperfections are to be assessed in individual cases because this depends on the requirements for the particular brazed joint. These imperfections are not always detectable by the use of non-destructive testing alone.

This document covers only imperfections that can occur in connection with brazing without the effect of any additional service loads. Only the type, shape and position of such imperfections are covered; no indication is given of the conditions of occurrence or causes.

For requirements for brazed joints which are relevant and essential to the particular function of the component, reference can be made to the relevant documentation, [e.g. for example](#) manufacturing documents or procedure sheets.

It is important that these requirements be precisely prescribed and that conformity with them be verifiable. Conformity can be established by testing either the brazed assembly itself or a test piece produced under comparable conditions.

This document does not specify requirements for acceptance levels for imperfections, since these will differ very markedly depending on the application, but it does suggest some quality levels which could be of value in the absence of more detailed information.

For the purposes of this document, the areas of a brazed assembly are designated as shown schematically in [Figure 1](#).

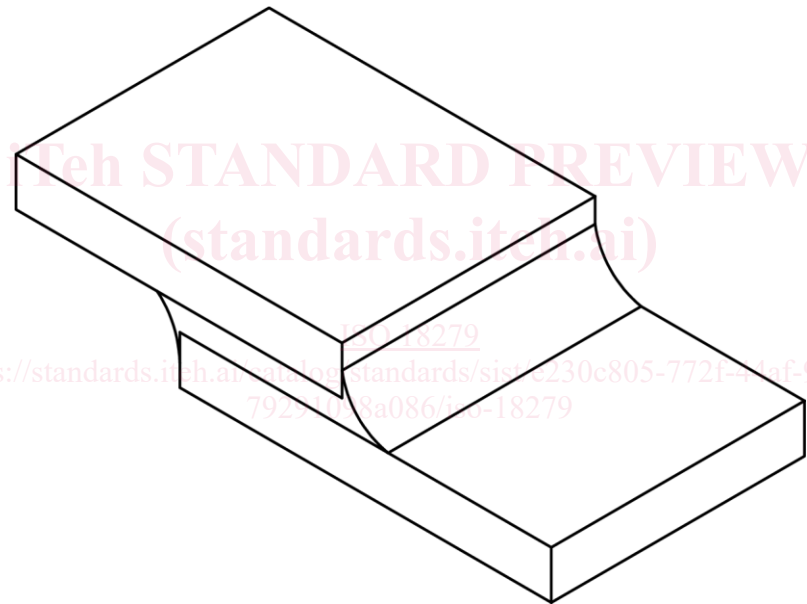
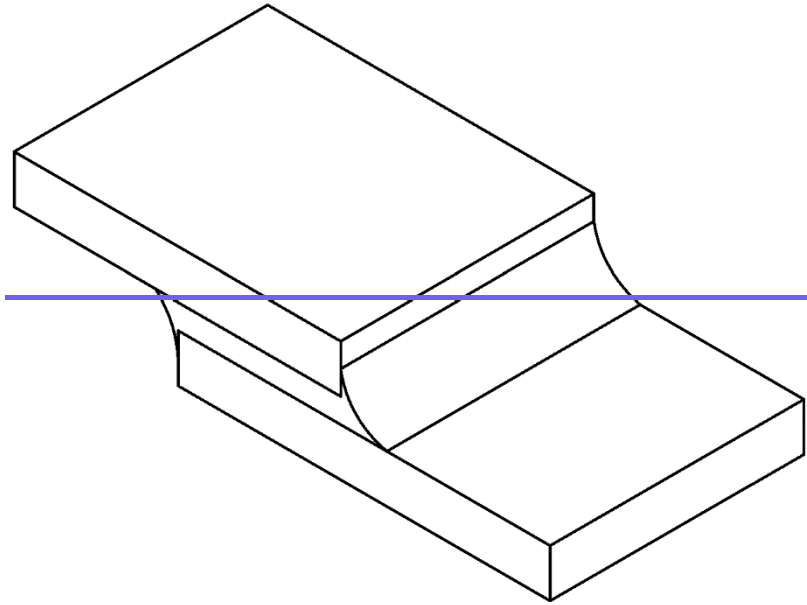

a) Simple brazed assembly

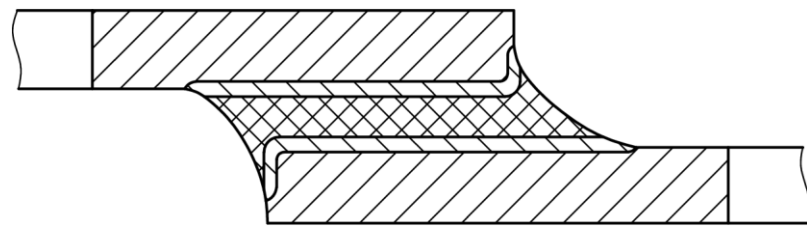
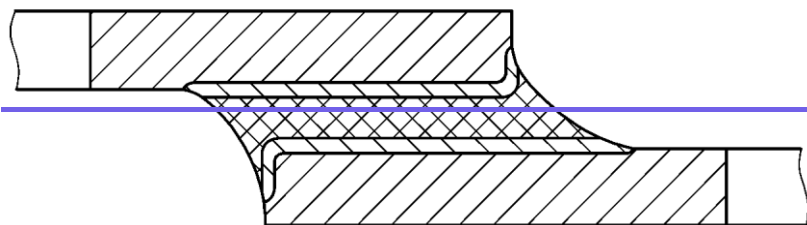

b) Section through assembly in a)

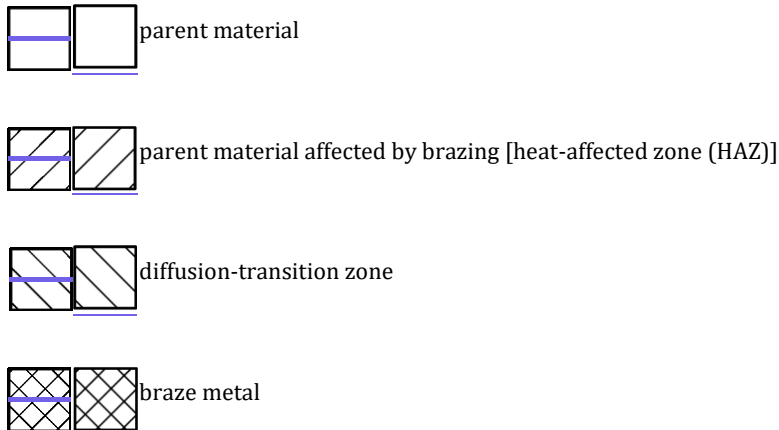
Key

NOTE Extent of HAZ will vary with materials and brazing process.

Figure 1 — Schematic of brazed assembly

2 Normative references

There are no normative references in this document.

3 Terms and definitions

For the purposes of this document, the following terms and definitions apply.

ISO and IEC maintain terminology databases for use in standardization at the following addresses:

- —ISO Online browsing platform: available at <https://www.iso.org/obp>
- —IEC Electropedia: available at <https://www.electropedia.org/>

3.1

imperfection

irregularity in the brazed joint or deviation from the intended relative positions of the parts joined by brazing and from the intended shape of the brazed component, where such deviations are dependent on the brazing

EXAMPLE For an example of an imperfection see [Figure 2](#).

4 Symbols

For the purposes of this document, the following symbols apply.

- l length of the brazed overlap;
- l_r required brazed length;
- l_u length of overlap before brazing;
- $l_{1,2}$ dimensions of the brazed imperfection;
- t_j thickness of brazed joint;
- $t_{1,2}$ wall or plate thickness or thicknesses.

[Figure 2](#) illustrates a planar imperfection by using the symbols.

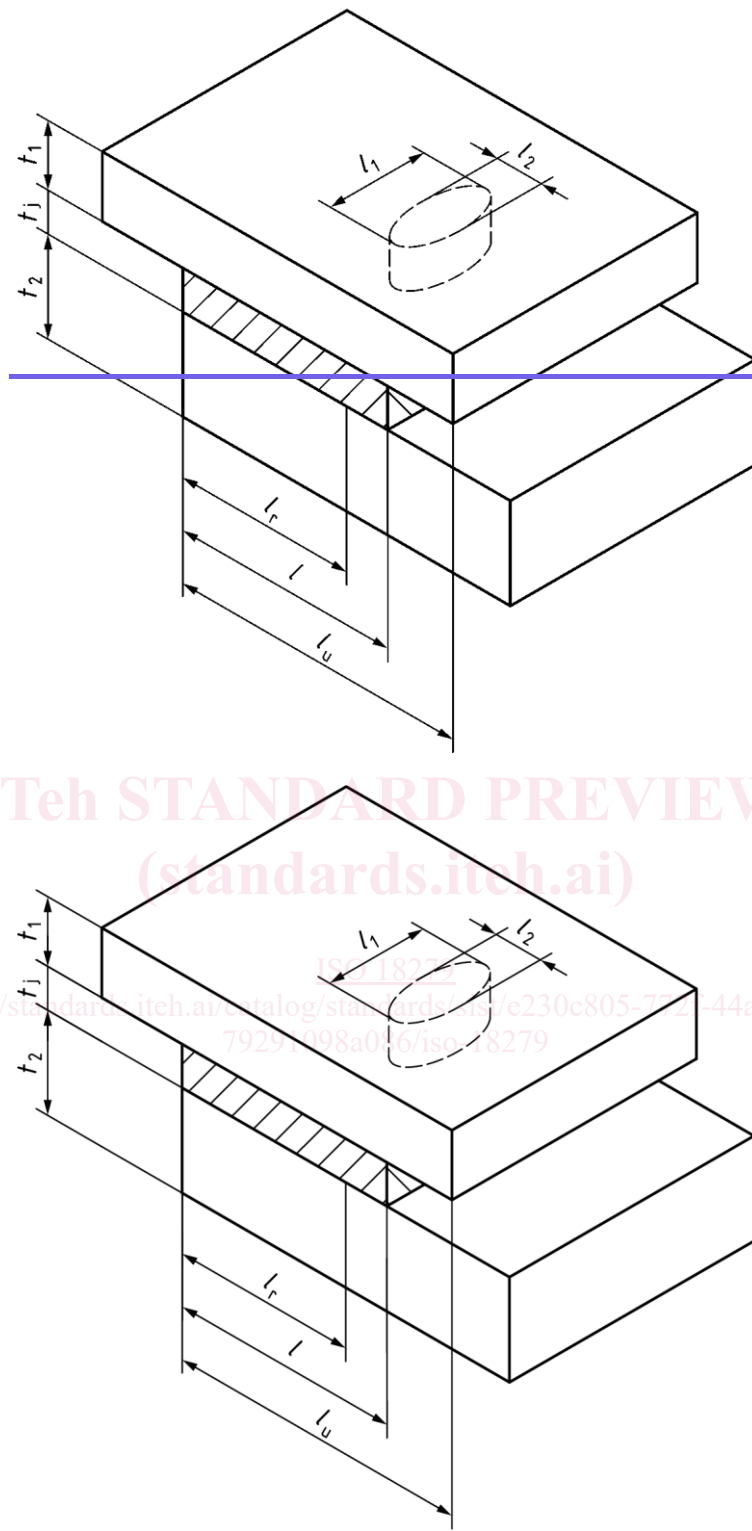

Figure 2 — Symbols used for dimensions

5 Classification

5.1 General

The imperfections are classified into six groups as follows:

- group I: cracks;

- ~~—~~group II: cavities;
- ~~—~~group III: solid inclusions;
- ~~—~~group IV: bonding imperfections;
- ~~—~~group V: shape and size imperfections;
- ~~—~~group VI: miscellaneous imperfections.

Imperfections are identified by designations which are given with descriptions in [Table 1](#)~~Table 1.~~

A further distinction can be made between the external and internal imperfections that can occur in brazed joints.

5.2 External imperfections

External imperfections in brazed joints include:

- ~~—~~underfill;
- ~~—~~crack(s);
- ~~—~~surface-breaking porosity;
- ~~—~~incomplete fillet;
- ~~—~~overlap;
- ~~—~~localized melting;
- ~~—~~rough surface of seam;
- ~~—~~flux seepage;
- ~~—~~discolouration;
- ~~—~~spatter;
- ~~—~~residual flux;
- ~~—~~surface erosion of parent material.

5.3 Internal imperfections

Internal imperfections in brazed joints include:

- ~~—~~crack(s);
- ~~—~~filling imperfection;
- ~~—~~solid inclusion;
- ~~—~~gas entrapment;
- ~~—~~flux inclusion;
- ~~—~~lack of fusion;