



Standard Test Method for Windload Resistance of Rigid Plastic Siding¹

This standard is issued under the fixed designation D5206; the number immediately following the designation indicates the year of original adoption or, in the case of revision, the year of last revision. A number in parentheses indicates the year of last reapproval. A superscript epsilon (ϵ) indicates an editorial change since the last revision or reapproval.

1. Scope

1.1 This test method describes methods for testing and evaluating windload resistance of rigid plastic siding when fastened in accordance with Practice D4756.

1.2 The proper use of this test method requires a knowledge of the principles of pressure measurement.

1.3 This test method describes the apparatus and the procedures to be used to determine an average maximum sustained static test pressure, or ultimate test pressure values, or both, with static pressure applied uniformly to a specimen.

NOTE 1—There is no known ISO equivalent to this test method.

1.4 The values expressed in inch-pound units are to be regarded as the standard. The SI equivalents in parentheses are for information only.

1.5 *This standard does not purport to address all of the safety concerns, if any, associated with its use. It is the responsibility of the user of this standard to establish appropriate safety and health practices and determine the applicability of regulatory limitations prior to use.* For specific precautionary statements, see Section 7.

2. Referenced Documents

2.1 ASTM Standards:²

D883 Terminology Relating to Plastics

D1600 Terminology for Abbreviated Terms Relating to Plastics

D3679 Specification for Rigid Poly(Vinyl Chloride) (PVC) Siding

D4756 Practice for Installation of Rigid Poly(Vinyl Chloride) (PVC) Siding and Soffit

E631 Terminology of Building Constructions

¹ This test method is under the jurisdiction of ASTM Committee D20 on Plastics and is the direct responsibility of Subcommittee D20.24 on Plastic Building Products.

Current edition approved Jan. 1, 2013. Published January 2013. Originally approved in 1991. Last previous edition approved in 2006 as D5602 – 06a. DOI: 10.1520/D5206-13.

² For referenced ASTM standards, visit the ASTM website, www.astm.org, or contact ASTM Customer Service at service@astm.org. For *Annual Book of ASTM Standards* volume information, refer to the standard's Document Summary page on the ASTM website.

3. Terminology

3.1 *General*—Definitions are in accordance with Terminologies D883 and E631 and abbreviations are in accordance with Terminology D1600 unless otherwise indicated.

3.2 Definitions of Terms Specific to This Standard:

3.2.1 *maximum sustained static test pressure*—the greatest difference in static air pressure (negative or positive) that a test specimen withstands without failure, expressed as force per square foot (or pascals).

3.2.2 *nail hem thickness*—the average thickness of the nail hem as measured between the nail slots.

3.2.3 *specimen*—the entire assembled siding panel as described in Section 8.

3.2.4 *static test pressure*—the specific difference in static air pressure (positive or negative) for which the specimen is to be tested expressed as force per square foot (or pascals).

3.2.5 *ultimate test pressure*—the difference in static air pressure (positive or negative) at which failure occurs expressed as force per square foot (or pascals).

4. Summary of Test Method

4.1 This method can be used to determine either the maximum sustained static test pressure or the ultimate pressure, or both, for the siding specimen. The procedure consists of sealing the test specimen with or against one face of a test chamber, supplying air to or exhausting air from the chamber at a rate required to maintain a specific static air pressure across the specimen for a specific time period. Pressure is applied in increments and the sample observed for failure at each stage, to determine the maximum sustained static test pressure, the ultimate test pressure, or both.

5. Significance and Use

5.1 This test method is a standard procedure for determining windload resistance of rigid plastic siding under specified uniform static pressure difference. This typically is intended to represent the effects of wind loads on exterior building surfaces. The actual loading on building surfaces is quite complex, varying with wind direction, time, height above ground, building shape, terrain, surrounding structures, and other factors.

5.2 Design wind pressure is selected for specific geographical locations from wind velocity maps prepared by the National Weather Service or other sources. Refer to Annex A1 of Specification D3679 for additional detailed information relating to use of this test method for evaluation of rigid poly(vinyl chloride) (PVC) siding.

NOTE 2—In applying the results of this test method, note that the performance of rigid PVC siding is a function of installation, and the specimen may or may not truly represent the actual application. In service, performance will also depend on the rigidity of supporting construction, and on the resistance of other components to deterioration by various causes, to thermal expansion and contraction, etc.

6. Apparatus

6.1 The description of apparatus is general in nature; any equipment capable of performing the test procedure within the allowable tolerances is permitted.

6.2 Major Components (See Fig. 1):

6.2.1 Test Chamber—A test chamber or box with an opening, a removable mounting panel, or one open side in which or against which the specimen is installed. Either the positive test chamber configuration or the negative test chamber configuration shall be used to perform this test. (See Fig. 1.) At least one static pressure tap shall be provided to measure the chamber pressure and shall be so located that the reading is unaffected by the velocity of the air supply to or from the chamber or any other air movement. The air supply opening into the chamber shall be arranged so that the air does not impinge directly on the test specimen with any significant

velocity. A means of access into the chamber to facilitate adjustments, observations, and measurements after the specimen has been installed is permitted.

NOTE 3—The test chamber or the specimen mounting frame, or both, must not deflect under the test load in such a manner that the performance of the specimen will be affected.

6.2.2 Air System—A controllable blower, a compressed air supply, an exhaust system, or reversible controllable blower designed to provide the required maximum air pressure difference across the specimen. The system shall provide an essentially constant air pressure difference for the required test period.

6.2.3 Pressure Measuring Apparatus—A device to measure the test pressure difference within a tolerance of ±2 %.

7. Safety Precautions

7.1 Take proper precautions to protect the observers in the event of any failure. At the pressures used in this test method, considerable energy and hazard are involved. In cases of failure, the hazard to personnel is less with a negative pressure configuration, as the specimen will tend to blow into the test chamber rather than out. Do not permit personnel in such chambers during tests and lockout chambers during tests.

8. Test Specimens

8.1 Sampling—Siding samples for test specimens shall be selected at random from production stock.

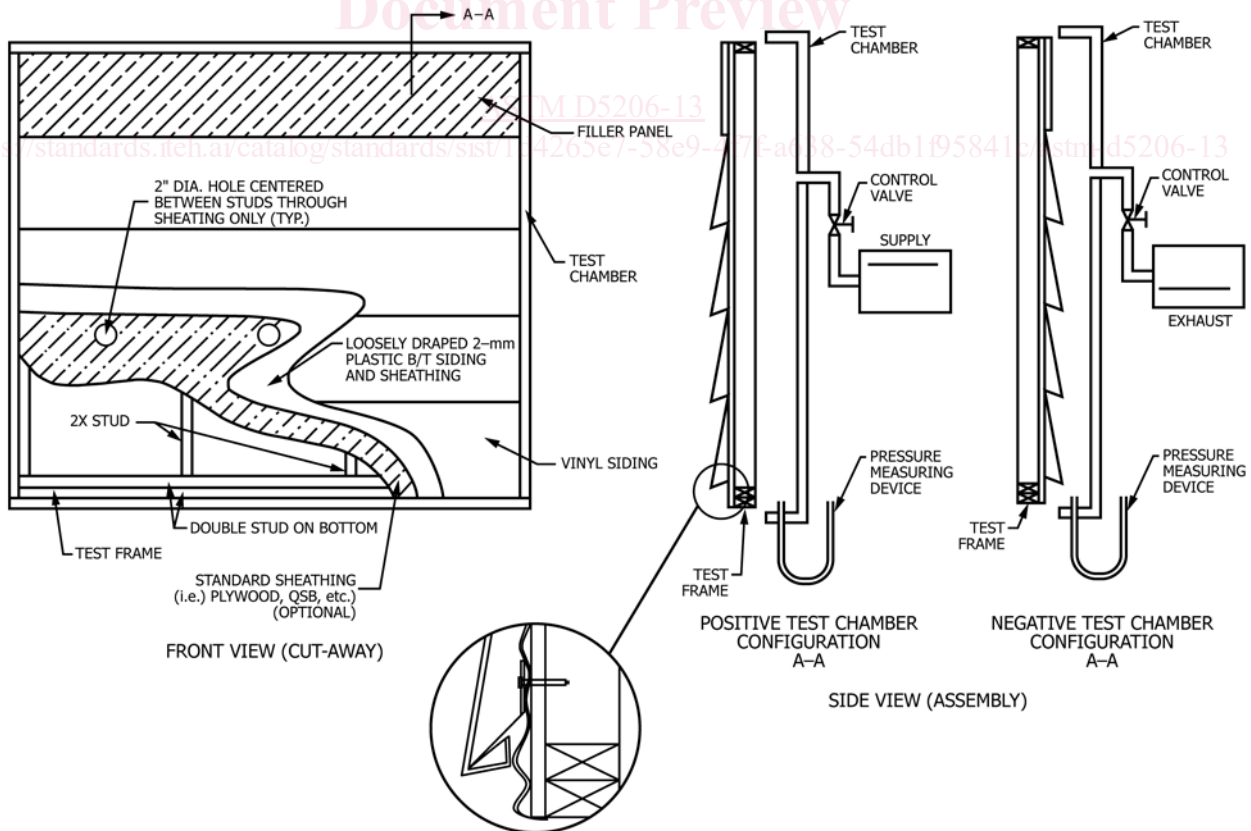

FIG. 1 Test Chamber