



Designation: **F1587—12 F1587 – 12a**

Standard Specification for Head and Face Protective Equipment for Ice Hockey Goaltenders¹

This standard is issued under the fixed designation F1587; the number immediately following the designation indicates the year of original adoption or, in the case of revision, the year of last revision. A number in parentheses indicates the year of last reapproval. A superscript epsilon (ϵ) indicates an editorial change since the last revision or reapproval.

INTRODUCTION

Ice hockey is a contact sport with intrinsic hazards. The use of protective equipment will not eliminate all injuries but should substantially reduce the severity and frequency of many injuries. Participation in the sport of ice hockey by a player implies acceptance of some risk of injury. The goal is to reduce the risk.

This performance specification for ice hockey goaltender head and face protective equipment has been prepared after consideration of head and face protection relative to the following principle risks: high-mass/low-velocity impact with respect to head protection, low-mass/high-velocity with respect to face protection (various playing situations), and fit. This performance specification may be modified as other risks are identified.

Performance requirements were determined after consideration of the state of the art of head and face protective design and manufacture. This specification was developed to address the unique demands and hazards associated with the position of ice hockey goaltender.

Two types of protectors are designated. Both types are subject to impact resistance and shock attenuation requirements. Type I protectors are subject to hockey stick blade penetration resistance requirements over their entire area of coverage. Type II protectors are subject to hockey puck penetration resistance requirements within the area of the field of vision and hockey stick blade penetration resistance requirements over the remainder of the area of coverage. It is recommended that Type II protectors be used only by players 18 years of age and older.

1. Scope

[ASTM F1587-12a](#)

1.1 This performance specification² covers performance requirements for ice hockey goaltender head and face protectors.

1.2 The intent of this performance specification is to reduce the risk of injury to the head and face of ice hockey goaltenders without compromising the form and appeal of the game.

1.3 This specification has requirements for: (1) materials, assembly, and design; (2) protected areas (coverage) and penetration resistance; (3) shock absorption; (4) puck impact resistance; (5) extensibility and strength of the chin strap and its attachment; and (6) optical quality.

1.4 *Units*—The values stated in SI units are to be regarded as the standard. No other units of measurement are included in this standard.

1.5 *This standard does not purport to address all of the safety concerns, if any, associated with its use. It is the responsibility of the user of this standard to establish appropriate safety and health practices and determine the applicability of regulatory limitations prior to use.*

¹ This specification is under the jurisdiction of ASTM Committee F08 on Sports Equipment, Playing Surfaces, and Facilities and is the direct responsibility of Subcommittee F08.15 on Ice Hockey.

Current edition approved Jan. 1, 2012 Dec. 1, 2012. Published March 2012 January 2013. Originally approved in 1995. Last previous edition approved in 2005 2012 as F1587—99 (2005):F1587 – 12. DOI: 10.1520/F1587-12;10.1520/F1587-12A.

² This performance specification is subject to revision as indicated by subsequent injury statistics and subject to review at least every five years.

2. Referenced Documents

2.1 *ASTM Standards*:³

[D2240 Test Method for Rubber Property—Durometer Hardness](#)

2.2 *CSA Standard*:

[CSA Z262.6-02 Specifications for Facially Featured Headforms](#)⁴

2.3 *CEN Standard*:

[BS EN 960:2006 Headforms for Use in the Testing of Protective Helmets](#)⁵

3. Terminology

3.1 *Definitions of Terms Specific to This Standard*:

3.1.1 *acceleration, a, of a body, n*—acceleration measured in metres per second squared.

3.1.1.1 *acceleration of a body as a result of gravity, n*—rate of change in velocity of a body that is subjected to gravity in units of g where $g = 9.8 \text{ m/s}^2$.

3.1.1.2 *acceleration, maximum, a_{max} , n*—highest point on the acceleration-time curve encountered during impact measured in units of g .

3.1.2 *backplate, n*—section of a goaltender’s mask that covers the posterior of the wearer’s head in a style of protector in which a front section and a rear section of the protector move relative to each other for the wearer to put on or remove the protector.

3.1.3 *central vertical axis, n*—line relative to the headform that lies in the median plane of symmetry and is normal to the basic plane at a point equidistant from the front and back of the headform.

3.1.4 *chip, n*—readily visible particle missing from the protector with an area bigger than 9 mm^2 .

3.1.5 *collimated light source (source of illumination), n*—quartz halogen lamp (17 lux) producing a 100-mm beam at a 6-m distance that is centered on the pupils of the eyes of the headform or the midpoint between the pupils of the eyes of the headform; this centering is maintained at all times during the optical quality test.

3.1.6 *combination, n*—combined unit of a face protector placed on a head protector with which it is designed to be used.

3.1.7 *computer interface, n*—linkage between the computer, the goniometer, and the sensors that enables a fully automated measurement process via a menu-driven operation during the optical quality test.

3.1.8 *drop height, n*—vertical distance between the lowest point (impact point) of the elevated mask and the apex of the impact surface.

3.1.9 *face protector, n*—protector, either specially adapted to a helmet or forming a continuous unit, that is designed to protect the wearer’s head and face, or parts thereof, against injury.

3.1.10 *fastening system, n*—devices used to connect the components of a helmet.

3.1.11 *goaltender mask, n*—face protector intended for goaltenders that consists of: (1) a front portion to cover part of the face and jaw, (2) a covering for the eyes and face (face protector), and (3) a backplate.

3.1.12 *goniometer, n*—positioning device that moves the headform such that the angular rotation and movement in both the horizontal and vertical directions enable a spherical scan to be made of the fields of vision as seen through a face protector or visor.

3.1.13 *helmet, n*—device worn on the head that is intended to reduce the risk of head injury to ice hockey participants. Helmets can include: (1) a shock-attenuating system, (2) a retention system, and (3) manufacturers’ attachments.

3.1.14 *helmet-positioning index, HPI, n*—vertical distance measured at the median plane from the front edge of the helmet to the reference plane when the helmet is placed on the reference headform. In the case of a mask with an opening in which a face protector is attached, the top front edge of the opening shall be used.

3.1.15 *impact sites*:—

3.1.15.1 *non-prescribed, adv*—any impact site, except the six prescribed sites, on or above the test line and at least one fifth of the circumference of the headform from any prior impact site.

3.1.15.2 *prescribed, adv*—see [Fig. 1](#).

(1) *front, adv*—located on the median plane and 50 mm above the anterior intersection of the median and reference planes.

(2) *front boss, n*—point on a plane 45° in a clockwise direction from the anterior intersection of the median and reference planes and 25 mm above the reference plane.

(3) *side, n*—located on the frontal plane and 25 mm above the point of intersection of the reference plane and the frontal plane.

(4) *rear boss, n*—point on a plane 135° in a clockwise direction from the anterior intersection of the median and reference planes

³ For referenced ASTM standards, visit the ASTM website, www.astm.org, or contact ASTM Customer Service at service@astm.org. For *Annual Book of ASTM Standards* volume information, refer to the standard’s Document Summary page on the ASTM website.

⁴ Available from the Canadian Standards Association, 178 Rexdale Blvd., Toronto, ON M9W 1R3 Canada.

⁵ Available from BSI Customer Services, 389 Chiswick High Rd., London W4 4AL United Kingdom.

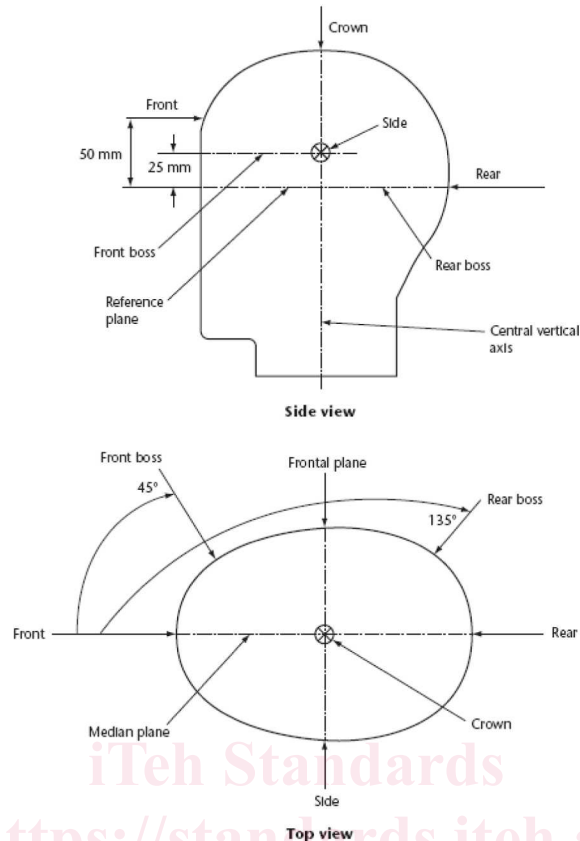

iTech Standards
(<https://standards.iteh.ai>)
Document Preview

NOTE 1—The impact direction is perpendicular to the surface of the headform for all impact sites.

FIG. 1 Prescribed Impact Sites

on the reference plane. If the protector is a mask with a back plate, the impact shall be delivered on the back plate, 19 mm from any edge.

- (5) *rear, n*—point at the posterior intersection of the median and reference planes.
- (6) *crown, n*—point at the intersection of the median and frontal planes.

3.1.15.3 *puck impact sites, n*—for testing face protectors, see Fig. 2.

(1) *side impact, n*—point halfway between the mouth level and the eye level in the horizontal plane, 25° to the median plane and in the direction of the axis formed by the intersection of the median plane and the frontal plane.

(2) *eye impact, n*—point in the horizontal plane 25° to the median plane and in the direction of the eye.

(3) *mouth impact, n*—point in the intersection between the horizontal plane and the median plane in the direction of the center of the mouth.

3.1.16 *laser, n*—luminous device used for alignment of the sensors.

3.1.17 *liner, n*—material inside the shell for the purpose of shock absorption or comfortable fit or both.

3.1.18 *model, n*—category of products that have the same essential characteristics (essential characteristics include materials, dimensions, construction, retention system, and protective padding).

3.1.19 *natural frequency, n*—frequency at which a system will tend to oscillate when displaced from its static equilibrium position.

3.1.20 *neck strap, n*—strap that is affixed to the two sides of the helmet and passes under the mandible in close proximity to the neck.

3.1.21 *no-contact zone, n*—designated zone of the headform where contact is not permitted during the puck impact resistance test (see 4.8 and Fig. 3).

3.1.22 *orbit, n*—the bony cavity containing the eyeball and other associated tissues.

3.1.23 *outer covering (shell), n*—outer material that gives the mask its form.

3.1.24 *peripheral field of vision, n*—projection outward of all retinal points (the nervous layer of the eye) at which visual sensations can be initiated (Fig. 4).

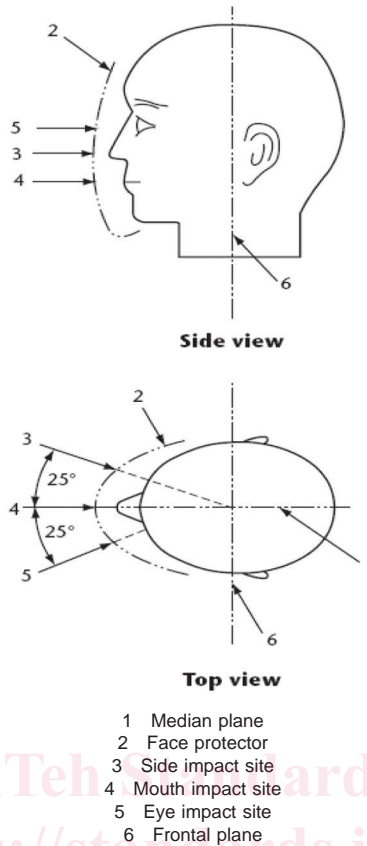

FIG. 2 Puck Impact Sites for Testing Face Protectors

3.1.24.1 *inferior (downward), adv*—angle in the vertical plane measured downward from the horizontal plane.

3.1.24.2 *nasal, adv*—angle in the horizontal plane measured from the primary position of gaze to the left for the right eye and from the primary position of gaze to the right for the left eye.

3.1.24.3 *superior (upward), adv*—angle in the vertical plane measured upward from the horizontal plane.

3.1.24.4 *temporal, adv*—angle in the horizontal plane measured from the primary position of gaze to the right for the right eye and from the primary position of gaze to the left for the left eye.

3.1.25 *permanent marking, n*—information that remains legible and cannot be removed in its entirety under conditions of normal use (see Section 7).

3.1.26 *photosensors, n*—sensors 5 mm in diameter centered in the pupils of the headform covered by a 5-mm translucent lens of 8-mm radius of curvature, convex forward.

3.1.26.1 Discussion—

(1) The photosensors are cosine corrected, for example, provided with diffusing covers that are a means of correcting the light-sensitive surface for wide angles of incidence. (2) Light contact with the sensors produces an electrical signal that is fed into a computer interface.

3.1.27 *planes, n*—see Fig. 5.

3.1.27.1 *basic plane of the human head, n*—plane that is located at the level of the external upper borders of the ear canal (external auditory meatus) and the inferior margins of the orbits of the eyes.

3.1.27.2 *basic plane of a headform, n*—plane relative to the headform that corresponds to the basic plane of the human head.

3.1.27.3 *frontal plane, n*—vertical plane that is perpendicular to the median and reference planes and passes through the top of the headform.

3.1.27.4 *horizontal plane, n*—plane that passes across the head at right angles to both the frontal and median plane.

3.1.27.5 *median plane, n*—vertical plane that passes through the headform from front to back and divides the headform into right and left halves.

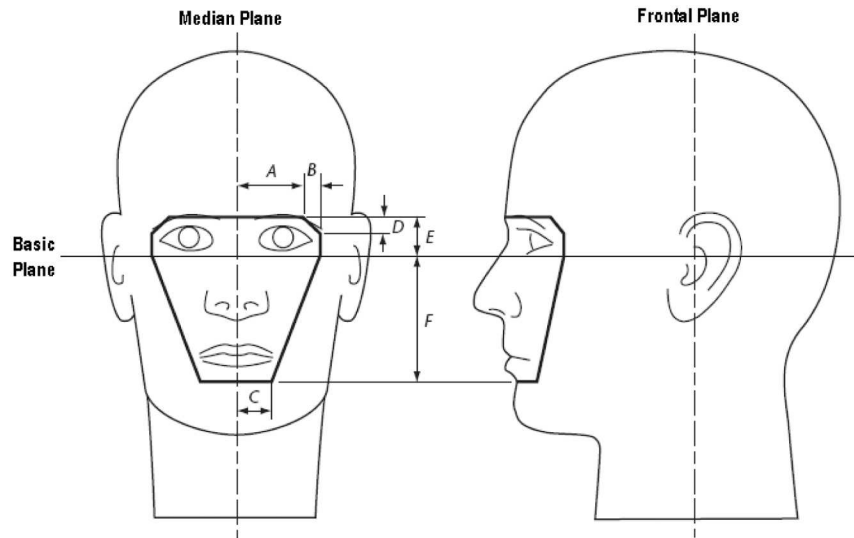

Facially Featured Headform (according to CSA Z262.6-02)	Dimensions (mm)					
	A	B	C	D	E	F
Adult (50th percentile)	48	16	28	17	36	68
Juvenile	60	0	25	0	36	60
Child	55	0	23	0	35	55

FIG. 3 No-Contact Zone (Projected Dimensions)

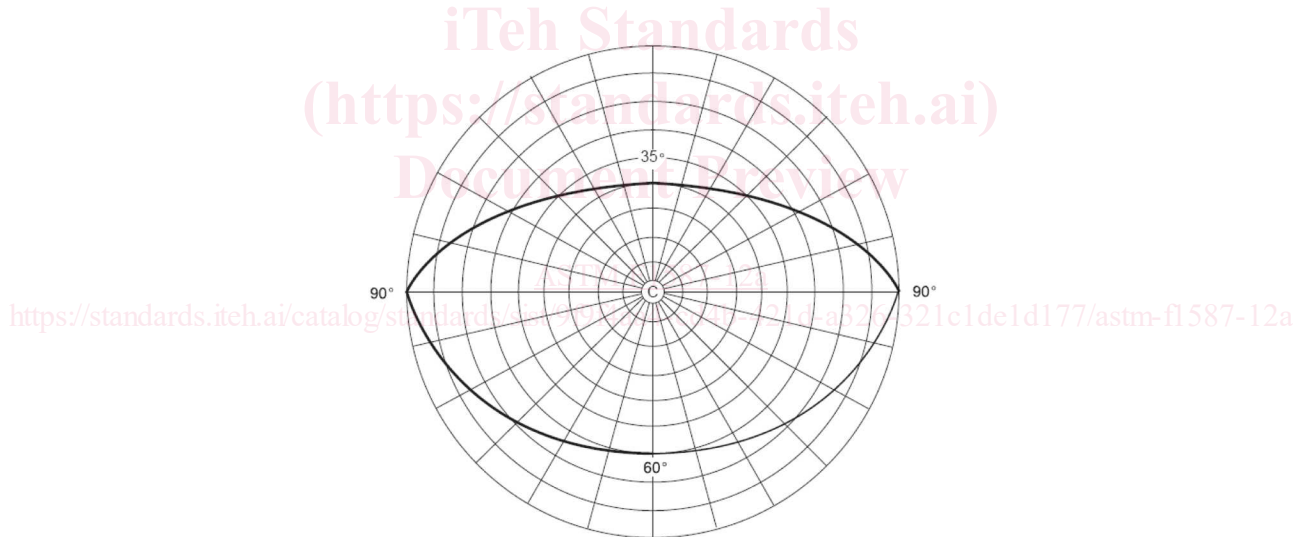

FIG. 4 Peripheral Field of Vision

3.1.27.6 *reference plane, n*—construction plane parallel to the basic plane of the headform at a distance from it which is a function of the size of the headform.

3.1.28 *primary position of gaze, n*—line running forward from the center of the pupil parallel to the median and horizontal planes.

3.1.29 *protector, n*—comprises a face protector either specially adapted to the helmet or forming a continuous unit designed to protect the whole or parts of the wearer’s head and face against injury.

3.1.30 *retention system, n*—system that secures the helmet firmly to the head, when adjusted according to the manufacturer’s instructions, by passing under the mandible in whole or in part.

3.1.31 *scan area, n*—oval area specified by superior, temporal, inferior, and nasal directions.

3.1.32 *scotomata, n*—blind spot in the field of vision.

3.1.33 *spherical impactor, n*—device made of low-resonance material that couples mechanically with the ball arm connector of a monorail drop assembly and is used for calibration of a monorail drop assembly.

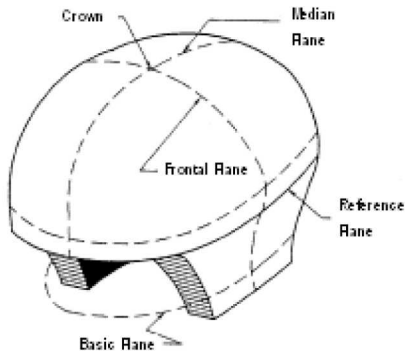

FIG. 5 Orientation Planes

Low-resonance material includes magnesium, aluminum alloy, and stainless steel.

3.1.34 *subnasale, Sn, n*—deepest point on the concavity of the anterior surface of the maxilla in the midline, within 3.0 mm of the floor of the nose (see Fig. 6).

3.1.35 *support assembly, n*—drop assembly in the monorail system minus the weight of the headform, ball arm, ball clamp, ball clamp bolts, and accelerometer.

3.1.36 *test area, n*—area on and above the test line where an impact site is located.

3.1.37 *test line, n*—line that defines the boundaries of the test area.

3.1.38 *threshold value, n*—output reading obtained when the collimated light beam has been centered on the midpoint between the pupils in the primary position of gaze.

3.1.38.1 Discussion—

The headform is rotated 90° in the horizontal plane, and the collimated light source contacts the pupillary sensor closest to the light source.

3.1.39 *types of protectors:*—

3.1.39.1 *Type I, n*—Combination head and face protectors that meet requirements for ice hockey stick blade penetration over the entire area of coverage.

ASTM F1587-12a

<https://standards.iteh.ai/catalog/standards/sist/9f94aa4-cd4b-421d-a326-321e1de1d177/astm-f1587-12a>

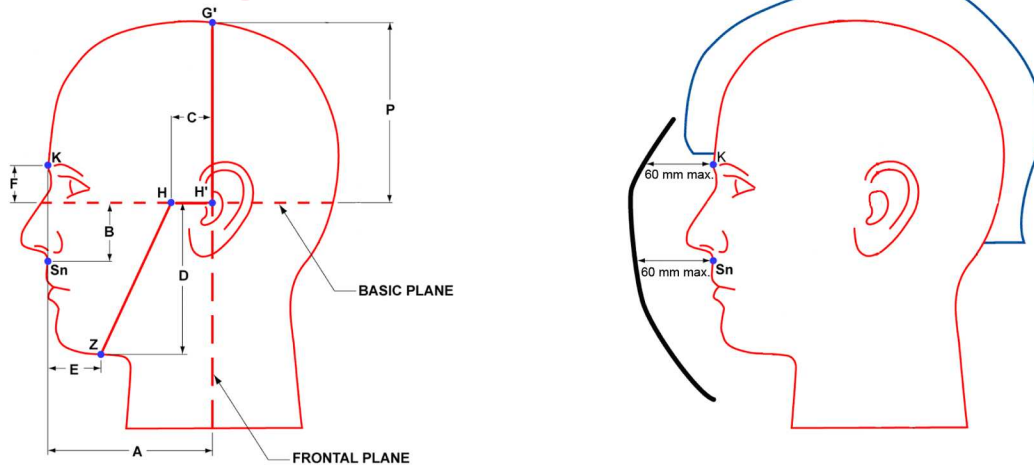

Goalkeeper G'-H'-H-Z-Z-H'-G'

Facially Featured Headform (according to CSA Z262.6-02)	Dimensions (mm)						
	A	B	C	D	E	F	P
Adult (50th percentile)	100.8	34	25.4	100.5	25	32	129.9
Juvenile	94.3	28	25.4	90	21	31	121.5
Child	91.1	22.5	25.4	79.5	21	21	102

FIG. 6 Minimum Protected Area (Coverage) of the Face

3.1.39.2 *Type II, n*—Combination head and face protectors that meet the requirements for ice hockey puck penetration resistance over the area of the field of vision and the requirements for ice hockey stick blade penetration resistance over the remainder of the area of coverage.

4. Requirements

4.1 *General*—A goaltender mask shall be capable of meeting the requirements in this performance specification throughout its full range of adjustment.

4.2 *Material:*

4.2.1 *Integrity*—All materials used in the fabrication of masks shall be known to be suitable for the intended application. They shall be resistant to irreversible polymeric changes when exposed to temperatures of up to 70°C or ultraviolet radiation. All materials shall be rot resistant and shall not undergo significant loss of strength, flexibility, or other physical change as a result of contact with perspiration, oil, or grease from the wearer’s hair. In addition, paints, glues, and finishes used in manufacture shall be compatible with the mask shell and shock absorption system materials.

4.2.2 *Cleaners*—Any material used in the construction of masks shall not be adversely affected by ordinary household soap and water, mild household detergent, or cleaners recommended by the manufacturer.

4.2.3 *Non-irritants*—Materials coming into contact with the wearer’s head shall not be the type known to cause skin irritation or disease.

4.2.4 *Documentation*—The manufacturer shall provide documentation indicating that the materials used in the construction of the mask meet the requirements of 4.2.1-4.2.3.

4.3 *Assembly:*

4.3.1 *Component Assemblies*—A goaltender mask may be assembled from a separate head and face protector provided that the combination meets all of the requirements of this specification and that the components are designed to be compatible without modification.

4.3.2 *Attachment System*—The mask shall be designed to allow the face protector to be attached to the helmet without requiring any operation of machines by the user.

4.3.3 The methods of assembling protector components shall be such as to prevent disengagement of the components from each other and from the test headforms as a result of the tests performed under this specification.

4.3.4 Padding or cushioning material shall be incorporated in such a way as to cover all hard surfaces that could otherwise come into contact with the wearer’s head. The method of securing padding shall not fail to maintain the padding material in position under normal conditions of heat, cold, moisture, or force distortion by the wearer.

4.4 *Design:*

4.4.1 *Finishes*—All parts shall be well finished and free of any sharp edges or other irregularities that could present a potential hazard to the user or an opposing player.

4.4.2 *External Projections*—In protectors that incorporate a backplate, the edge of the front section, which extends over the backplate, shall not project more than 25.4 mm beyond the adjacent edges of the backplate, as measured along a square-ended 12.7-mm diameter cylindrical rod, when the rod end is inserted behind the projecting edge of the front section and along the inner surface of the front section until the end of the rod is flush with the outer edge of the backplate.

4.4.3 *Access*—All protectors shall be so constructed that access to the wearer’s face is provided, without the use of tools, and without causing movement to the cervical spine, in the event of injury. The access provided shall be sufficient for the administration of cardiopulmonary resuscitation to the wearer.

4.4.4 Protectors should be designed to minimize rotation on the head under the normal stresses encountered in use.

4.4.5 *Welded Wire Components*—All wire ends shall terminate at the perimeter of the wire component and shall overlap the shell material of the protector in such a way as to prevent stick or puck entry between components.

4.4.6 *Attachments*—The fasteners for securing components to the shell shall be so attached that the degree of protection afforded the wearer by the protective padding or cushioning material of the helmet is not thereby reduced.

4.4.7 *Maximum Distance (Face Protector to Headform)*—The distance measured on the median plane, parallel to the basic plane, between the inside of the face protector and Points K and Sn on the facially featured headform shall not exceed 60 mm (see Fig. 6).

4.4.8 *Minimum Distance (Face Protector to Headform)*—Except where it is covered by padding, no part of the mask shall be closer than 10 mm to the surface of the facially featured headform.

4.4.9 *Load-Bearing Area*—Masks shall have a minimum padded load-bearing area in accordance with Fig. 7.

4.4.10 *Overlap:*

4.4.10.1 Where the face protector portion is made to overlap the edges of the open front portion of the mask, it shall do so by at least 6 mm.

4.4.10.2 For a face protector/helmet combination, the face protector shall overlap the lower edge of the helmet by at least 6 mm.

4.5 *Protected Areas (Coverage):*

4.5.1 The protected areas shall correspond to the headform size with which the mask is to be tested.

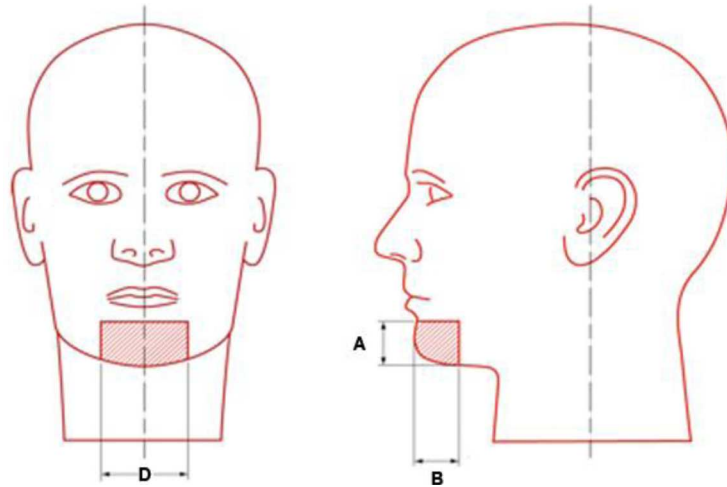

Facially Featured Headform (according to CSA Z262.6-02)	Dimensions (mm)		
	D	A	B
Adult (50th Percentile)	53	18–27	18
Juvenile	48	15–24	15
Child	42	15–24	15

FIG. 7 Minimum Load-Bearing Area

4.5.2 *Protected Area of the Head*—The mask shall cover, at minimum, the area above the Line B-CL-DL-EL-F-ER-DR –CR-B (where L is left and R is right) in Fig. 8 when the mask is tested in accordance with 5.4.1.

4.5.3 *Ear Aperture*—No ear aperture shall have a linear dimension exceeding 38 mm. The distance to any other edge of the helmet shall be not less than 20 mm. The ear aperture shall be completely surrounded by the outer covering of the mask (shell).

4.5.4 *Ventilation Openings*—Ventilation openings shall meet the requirements of 4.6.

4.5.5 *Protected Area of the Face*—The mask shall cover the front portion of the area extending to at least the Line G'-H'-L-HL-Z-HR-H'R-G' (where L is left and R is right) in Fig. 6 when the mask is tested in accordance with 5.4.2.

4.6 *Penetration Resistance*—With the exception of the ear apertures and when tested in accordance with 5.5:

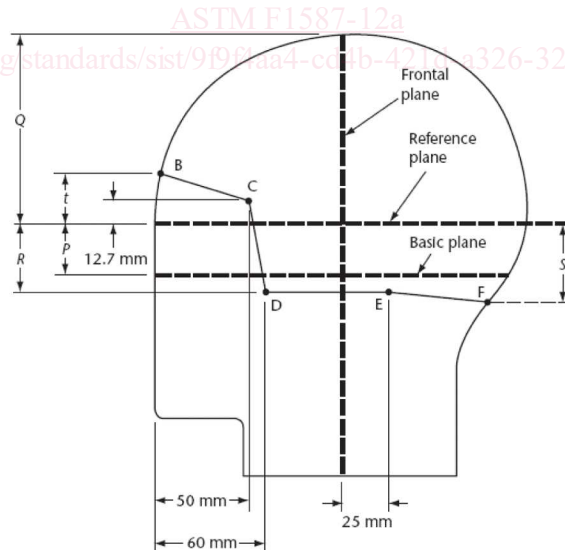

Headform Circumference, mm	Dimensions (mm)				
	P	Q	R	S	T
495	23.5	89.7	33.3	42.3	24
535	25.5	96	32	44	26
575	27.5	102.4	27.5	42.5	27
605	29	107.2	25	44	28

FIG. 8 Minimum Protected Area (Coverage) of the Head

- 4.6.1 *Type I*—There shall be no contact with the bare headform by the test blade within the protected areas.
- 4.6.2 *Type II*—There shall be no contact with the bare headform by (1) the test disk over the area of the field of vision and (2) the test blade over the remainder of the protected areas.
- 4.7 *Shock-Absorbing Capacity*—When tested in accordance with 5.6, no single impact shall exceed a peak acceleration of 275 g under all impact test conditions. The outer covering (shell) shall remain intact with no cracks visible through its thickness.
- 4.8 *Puck Impact Resistance*:
- 4.8.1 *Contact Test*—Neither the protector nor the puck shall touch the facially featured headform within the no-contact zone (see Fig. 3) when tested in accordance with 5.7. The shock-absorbing material at the load-bearing area shall remain securely attached to the face protector. There shall be neither breakage of the structural components of the face protector nor failure of the protector’s points of attachment to the helmet. Cracking of surface coatings may be present, but there shall be no chips.
- 4.8.2 *Toughness Test*—When a mask is tested in accordance with 5.7, there shall be no breakage of the wire face protector.
- 4.9 *Retention System*:
- 4.9.1 *Neck Strap*—Protectors shall incorporate a neck strap with a minimum width of 13 mm.
- 4.9.2 *Extensibility and Strength*—When tested in accordance with 5.8, the displacement of the roller holder shall not exceed 25 mm during a load of between 5 and 110 N. The release force shall be not less than 110 N and not more than 300 N.
- 4.10 *Optical Quality*:
- 4.10.1 *Peripheral Field of Vision*—The field of vision for masks shall be tested in accordance with 5.9 at $20 \pm 2^\circ\text{C}$. There shall be no occultation in the field of vision bounded by the following angles (see Fig. 4):
- 4.10.1.1 35° in the superior direction,
- 4.10.1.2 60° in the inferior direction,
- 4.10.1.3 90° in the temporal direction, and
- 4.10.1.4 45° in the nasal direction.
- 4.10.2 *Scotomata*—When tested in accordance with 5.9, face protectors shall have no overlapping bilateral scotomata in the field of vision.

5. Test Methods

- 5.1 *General*:
- 5.1.1 *Samples*—Only new and complete goatender head/face protector combinations as offered for sale shall be tested. The masks shall be inspected visually and by hand before conditioning.
- 5.1.2 *Quantity*—For a given model/size, five complete masks and two additional face protectors shall be used as outlined in Tables 1 and 2. Samples shall be numbered 1, 2, 3, and so forth.
- 5.1.3 *Assembly*—Face protectors shall be assembled and mounted on the appropriate helmet in accordance with the manufacturer’s instructions.
- 5.2 *Conditioning*:
- 5.2.1 *Ambient Conditioning*—The sample shall be exposed to a temperature of $20 \pm 2^\circ\text{C}$ and a relative humidity not exceeding 55 % for not less than 4 h.
- 5.2.2 *Low-Temperature Conditioning*—~~Low-Temperature Conditioning~~ The sample shall be exposed to a temperature of -23 to -27°C . Helmets shall be conditioned for a period of not less than 4 h nor more than 24 h. Testing shall begin within 40 s of removal from the low temperature chamber.
- 5.2.3 *Elevated Temperature Conditioning*—The sample shall be exposed to a temperature of $30 \pm 2^\circ\text{C}$ for not less than 24 h. Testing shall begin within 40 s of removal from the heating chamber.

TABLE 1 Protocol for Shock-Absorbing Capacity Testing

NOTE 1—Masks shall be impacted three times at the site that yielded the highest peak g under ambient temperature conditions.

NOTE 2—An extra sample (No. 5) is reserved for failures.

Sample No. (for Each Model Size)	Conditioning	Impact Site	Impacts per Site	Drop Velocity
1	Ambient temperature (see 5.2.1)	Crown, one side, front, front boss, rear boss, and rear (see Fig. 1)	3	4.5 m/s \pm 2 %
2	Ambient temperature (see 5.2.1)	Non-prescribed sites 1 and 2 (on or above the test line)	3	4.5 m/s \pm 2 %
3	Low temperature (see 5.2.2)	See Note 1	3	4.5 m/s \pm 2 %
4	Elevated temperature (see 5.2.3)	See Note 1	3	4.5 m/s \pm 2 %

TABLE 2 Protocol for Puck Impact Resistance Testing

Type	Test	Sample No.	Impact Site	Conditioning	Puck Velocity	
I and II	Contact	1	Eye	Ambient temperature (see 5.2.1)	33 ± 1 m/s	
		2	Mouth			
		3	Side			
	Toughness	4	Eye	Low temperature (see 5.2.2)	36 ± 1 m/s	Mouth
5			Side			
6						

TABLE 2 Protocol for Puck Impact Resistance Testing

Sample #	In combination with Helmet Sample # as identified in Table 1	Test	Conditioning Temperature	Impact Sites	Puck Velocity	Test Method Clauses
1	1	Contact	Ambient	eye	33 ± 1 m/s	
2	2			mouth		
3	3			side		5.7
4	4	Toughness	Low	eye	36 ± 1 m/s	
5				mouth		
6				side		
7	5		Ambient			5.4.2, 5.5, 5.9

5.2.4 *Testing Conditioned Masks*—Testing shall be completed within 5 min after the removal of the mask from the conditioning environment specified in 5.2.2 and 5.2.3. Masks may be returned to the conditioning environment to meet this requirement. Before the resumption of testing, masks shall remain in the conditioning environment for a minimum of 15 min for each 5 min they are out of the conditioning environment.

5.3 *Helmet-Positioning Index (HPI) and Headform Size*—The HPI and corresponding headform size shall be specified by the mask manufacturer. Where the HPI and corresponding headform size are not available from the manufacturer, the mask shall not be tested.

5.4 *Protected Area (Coverage) Test:*

5.4.1 *Protected Area of the Head:*

5.4.1.1 *Headform*—The headforms specified in EN 960:2006 shall be used.

5.4.1.2 *Positioning*—The mask shall be positioned on the largest headform for its size range using the HPI (see 5.3). A load of 50 N shall be applied to the crown of the helmet, perpendicular to the helmet, to seat the helmet to the headform.

5.4.2 *Protected Area of the Face:*

5.4.2.1 *Headform*—The facially featured headforms specified in CSA Z262.6-02 shall be used.

5.4.2.2 *Positioning*—The masks shall be positioned on the largest headform for their size range so that the chin load-bearing component of the protector (that is, chin cup) rests on the chin of the headform (see Fig. 7).

5.4.3 The mask shall cover the areas of protection as required in 4.5.

5.5 *Penetration Test:*

5.5.1 *Test Apparatus*—The apparatus consists of:

5.5.1.1 *Headform*—Headforms to be used for the penetration tests shall be in accordance with:

- (1) EN 960:2006 when testing the protected area of the head and
- (2) CSA Z262.6-02 facially featured headforms when testing the protected area of the face.

5.5.1.2 Test blade in accordance with Fig. 9, made of steel (Type I and II) and

5.5.1.3 Test disk in accordance with Fig. 10, made of steel (Type II).

5.5.2 *Procedures:*

5.5.2.1 In general, an attempt shall be made to contact the headform by trying to enter the penetrator (at any angle and, in principle, without force) through openings within the protector’s perimeter and over the protected areas as specified in 5.5.2.2 and 5.5.2.3, excluding the ear apertures. Record whether contact with the bare headform surface is made or not. Specifically:

5.5.2.2 *Penetration Test Over the Protected Area of the Head:*

- (1) *Mask Positioning*—The mask shall be positioned on the largest headform for its size range using the HPI (see 5.3).
- (2) *Penetration Test*—An attempt shall be made to contact the headform through all of the protector’s openings within the protected area defined in 4.5.2 and Fig. 8 using the test blade.

5.5.2.3 *Penetration Test Over the Protected Area of the Face:*

(1) *Mask Positioning*—The mask shall be positioned on the largest headform for its size range so that the chin load-bearing component of the protector (that is, chin cup) rests on the chin of the headform.

(2) *Penetration Test (Type I)*—An attempt shall be made to contact the headform through all of the protector’s openings within the protected area defined in 4.5.5 and Fig. 6, using the test blade, or