



# FINAL DRAFT International Standard

## ISO/FDIS 11451-3

### Road vehicles — Vehicle test methods for electrical disturbances from narrowband radiated electromagnetic energy —

#### Part 3: On-board transmitter simulation

*Véhicules routiers — Méthodes d'essai d'un véhicule soumis  
à des perturbations électriques par rayonnement d'énergie  
électromagnétique en bande étroite —*

*Partie 3: Simulation des émetteurs embarqués*

ISO/TC 22/SC 32

Secretariat: JISC

Voting begins on:  
**2024-03-06**

Voting terminates on:  
**2024-05-01**

RECIPIENTS OF THIS DRAFT ARE INVITED TO SUBMIT, WITH THEIR COMMENTS, NOTIFICATION OF ANY RELEVANT PATENT RIGHTS OF WHICH THEY ARE AWARE AND TO PROVIDE SUPPORTING DOCUMENTATION.

IN ADDITION TO THEIR EVALUATION AS BEING ACCEPTABLE FOR INDUSTRIAL, TECHNOLOGICAL, COMMERCIAL AND USER PURPOSES, DRAFT INTERNATIONAL STANDARDS MAY ON OCCASION HAVE TO BE CONSIDERED IN THE LIGHT OF THEIR POTENTIAL TO BECOME STANDARDS TO WHICH REFERENCE MAY BE MADE IN NATIONAL REGULATIONS.

iTeh Standards  
(<https://standards.iteh.ai>)  
Document Preview

ISO/FDIS 11451-3

<https://standards.iteh.ai/catalog/standards/iso/2895eaa2-9a80-47c8-b53a-7911c0b55c22/iso-fdis-11451-3>



**COPYRIGHT PROTECTED DOCUMENT**

© ISO 2024

All rights reserved. Unless otherwise specified, or required in the context of its implementation, no part of this publication may be reproduced or utilized otherwise in any form or by any means, electronic or mechanical, including photocopying, or posting on the internet or an intranet, without prior written permission. Permission can be requested from either ISO at the address below or ISO's member body in the country of the requester.

ISO copyright office  
CP 401 • Ch. de Blandonnet 8  
CH-1214 Vernier, Geneva  
Phone: +41 22 749 01 11  
Email: [copyright@iso.org](mailto:copyright@iso.org)  
Website: [www.iso.org](http://www.iso.org)

Published in Switzerland

# Contents

	Page
Foreword.....	iv
<b>1 Scope</b> .....	<b>1</b>
<b>2 Normative references</b> .....	<b>1</b>
<b>3 Terms and definitions</b> .....	<b>1</b>
<b>4 Test conditions</b> .....	<b>1</b>
<b>5 Test location</b> .....	<b>2</b>
5.1 General.....	2
5.2 Absorber lined shielded enclosure (ALSE).....	2
5.3 Outdoor test site.....	2
<b>6 Test instrumentation</b> .....	<b>2</b>
6.1 General.....	2
6.2 Signal sources.....	3
6.2.1 Transmitters with antenna outside the vehicle.....	3
6.2.2 Transmitters with antenna inside the vehicle.....	3
6.3 Power monitoring.....	3
6.3.1 General.....	3
6.3.2 Dual directional coupler.....	3
6.3.3 Low loss coaxial cable.....	4
6.4 Vector network analyser (VNA).....	4
6.5 Antennas.....	4
6.5.1 Simulated on-board transmitters.....	4
6.5.2 Simulated portable transmitter.....	5
6.6 Stimulation and monitoring of the vehicle.....	5
<b>7 Test set-up</b> .....	<b>5</b>
7.1 Transmitters with antenna outside the vehicle.....	5
7.2 Transmitters with antenna inside the vehicle.....	8
7.2.1 General.....	8
7.2.2 Simulated portable transmitters.....	8
<b>8 Test procedure</b> .....	<b>9</b>
8.1 General.....	9
8.2 Test plan.....	9
8.3 Test method.....	10
8.3.1 Transmitters with antenna outside the vehicle.....	10
8.3.2 Transmitters with antenna inside the vehicle.....	11
8.4 Test report.....	12
<b>Annex A (normative) Net power characterization procedure</b> .....	<b>13</b>
<b>Annex B (informative) Typical characteristics and use of transmitters</b> .....	<b>26</b>
<b>Annex C (informative) Characteristics of simulated portable transmitter antenna</b> .....	<b>29</b>
<b>Annex D (informative) Function performance status classification (FPSC)</b> .....	<b>50</b>
<b>Bibliography</b> .....	<b>51</b>

## Foreword

ISO (the International Organization for Standardization) is a worldwide federation of national standards bodies (ISO member bodies). The work of preparing International Standards is normally carried out through ISO technical committees. Each member body interested in a subject for which a technical committee has been established has the right to be represented on that committee. International organizations, governmental and non-governmental, in liaison with ISO, also take part in the work. ISO collaborates closely with the International Electrotechnical Commission (IEC) on all matters of electrotechnical standardization.

The procedures used to develop this document and those intended for its further maintenance are described in the ISO/IEC Directives, Part 1. In particular, the different approval criteria needed for the different types of ISO document should be noted. This document was drafted in accordance with the editorial rules of the ISO/IEC Directives, Part 2 (see [www.iso.org/directives](http://www.iso.org/directives)).

ISO draws attention to the possibility that the implementation of this document may involve the use of (a) patent(s). ISO takes no position concerning the evidence, validity or applicability of any claimed patent rights in respect thereof. As of the date of publication of this document, ISO had not received notice of (a) patent(s) which may be required to implement this document. However, implementers are cautioned that this may not represent the latest information, which may be obtained from the patent database available at [www.iso.org/patents](http://www.iso.org/patents). ISO shall not be held responsible for identifying any or all such patent rights.

Any trade name used in this document is information given for the convenience of users and does not constitute an endorsement.

For an explanation of the voluntary nature of standards, the meaning of ISO specific terms and expressions related to conformity assessment, as well as information about ISO's adherence to the World Trade Organization (WTO) principles in the Technical Barriers to Trade (TBT), see [www.iso.org/iso/foreword.html](http://www.iso.org/iso/foreword.html).

This document was prepared by Technical Committee ISO/TC 22, *Road vehicles*, Subcommittee SC 32, *Electrical and electronic components and general system aspects*.

This fourth edition cancels and replaces the third edition (ISO 11451-3:2015), which has been technically revised.

The main changes are as follows:

- change of the frequency range from 1,8 MHz – 5,85 GHz to 1,8 MHz – 6 GHz;
- suppression of test methodology with commercial transmitters;
- use of modulation from ISO 11451-1;
- addition of new [Annex A](#) with description of test methodology for net power characterization procedure;
- addition in [Annex C](#) of microwave broadband dipole antenna and HF broadband sleeve antenna;
- addition of [Annex D](#) on function performance status classification (FPSC).

A list of all parts in the ISO 11451 series can be found on the ISO website.

Any feedback or questions on this document should be directed to the user's national standards body. A complete listing of these bodies can be found at [www.iso.org/members.html](http://www.iso.org/members.html).

# Road vehicles — Vehicle test methods for electrical disturbances from narrowband radiated electromagnetic energy —

## Part 3: On-board transmitter simulation

### 1 Scope

This document specifies methods for testing the immunity of passenger cars and commercial vehicles to electromagnetic disturbances from on-board transmitters connected to an external antenna and portable transmitters with integral antennas, regardless of the vehicle propulsion system (e.g. spark ignition engine, diesel engine, electric motor).

### 2 Normative references

The following documents are referred to in the text in such a way that some or all of their content constitutes requirements of this document. For dated references, only the edition cited applies. For undated references, the latest edition of the referenced document (including any amendments) applies.

ISO 11451-1, *Road vehicles — Vehicle test methods for electrical disturbances from narrowband radiated electromagnetic energy — Part 1: General principles and terminology*

### 3 Terms and definitions

For the purposes of this document, the terms and definitions given in ISO 11451-1 and the following apply.

ISO and IEC maintain terminology databases for use in standardization at the following addresses:

- ISO Online browsing platform: available at <https://www.iso.org/obp>
- IEC Electropedia: available at <https://www.electropedia.org/>

#### 3.1 integral antenna

permanent fixed antenna which may be built-in, designed as an indispensable part of the portable transmitting device

#### 3.2 peak power sensor

power sensor that allows direct measurement of the peak power of the modulated carrier signal

#### 3.3 average power sensor

power sensor that allows direct measurement of the average power of the modulated carrier signal

### 4 Test conditions

The applicable frequency range of the test method is 1,8 MHz to 6 GHz.

The user shall specify the test severity level(s) over the frequency range. Suggested test levels are included in [Annex D](#). Typical on-board transmitter characteristics (frequency bands, power level and modulation) are given in [Annex B](#).

Standard test conditions are given in ISO 11451-1 for the following:

- test temperature;
- supply voltage;
- dwell time;
- frequency step;
- modulation;
- test signal quality.

NOTE Alternate modulations, if required, can be found in [Annex B](#). Users of this document are advised that [Annex B](#) is for information only and cannot be considered as an exhaustive description of various portable transmitters available in all countries.

## 5 Test location

### 5.1 General

This test should typically be performed in an absorber lined shielded enclosure (ALSE). Where national regulations permit, the test can also be performed at an outdoor test site.

### 5.2 Absorber lined shielded enclosure (ALSE)

An absorber lined shielded enclosure with the characteristics specified in ISO 11451-2 should be used for this test.

NOTE At frequencies where absorbers are not effective, the reflections in the chamber can affect the exposure of the vehicle.

### 5.3 Outdoor test site

Where national regulations permit the use of an outdoor test site, the outdoor test site should have an area with a radius of 10 m free from large metal structures or objects. When performing outdoor test-site tests, it is important to be aware of harmonic suppression regulations.

## 6 Test instrumentation

### 6.1 General

The following test instrumentation is used:

- radio frequency (RF) generator with internal or external modulation capability;
- power amplifier;
- power measuring instrumentation to measure the forward and reverse power;
- dual directional coupler;
- low loss coaxial cables;
- vector network analyser (VNA);

- transmit antenna;
- direct current charging artificial network (DC- charging AN), and/or artificial mains networks (AMN), and/or asymmetric artificial networks (AAN).

## 6.2 Signal sources

### 6.2.1 Transmitters with antenna outside the vehicle

Signal sources for transmitters with antenna outside the vehicle should be simulated on-board transmitters (use of a signal generator and broadband power amplifier located external to the vehicle capable of generating radio frequency (RF) power in their operational frequency ranges with specific output power delivered to a test antenna or original equipment manufacturer (OEM) antenna fitted to the vehicle).

When using simulated on-board transmitters located external to the vehicle, it is advisable to place an RF choke (ferrite or powdered iron toroid) around the coaxial cable to the antenna to produce a minimum lossy impedance of 200 ohms. This facilitates reduction in cable shield skin currents and more closely simulate a transmitter installed in the vehicle.

### 6.2.2 Transmitters with antenna inside the vehicle

Signal sources for transmitters with antenna inside the vehicle should be simulated portable transmitters (use of a signal generator and broadband power amplifier located external to the vehicle capable of generating radio frequency (RF) power in their operational frequency ranges with specific output power). The power is delivered to a small passive antenna within the vehicle. Antennas used for this testing are described in [Annex C](#).

## 6.3 Power monitoring

### 6.3.1 General

Either power sensors or a spectrum analyser (or measurement receiver) shall be used for measurement of the forward and reflected power at the dual directional coupler. When power sensors are used to measure forward and reflected power:

- CW or AM signal shall be measured either with an average power sensor or a peak power sensor (peak conservation may be applied for AM per ISO 11451-1);
- pulsed power modulation shall be measured with a peak power sensor;
- when applying Broadband test signal, power measurement instrumentation shall be capable of measuring average and peak values of the channel power;
- power sensors should be connected directly to the coupler ports;
- power sensors shall exhibit a VSWR < 1,2 and measurement accuracy < 0,5 dB.

When a spectrum analyser (or measurement receiver) is used to measure forward and reflected power, it shall exhibit the same VSWR and measurement accuracy as required for power sensors. When the sensors or a spectrum analyser (or measurement receiver) are connected to the coupler via coaxial cables, the cable's transmission loss shall be taken into account during characterization. See [Annex A](#) for details.

### 6.3.2 Dual directional coupler

The coupler shall exhibit the following characteristics:

- coupling factor: > 20 dB (40 dB recommended),
- mainline port VSWR < 1,3,

- coupling port VSWR: < 1,5,
- mainline transmission loss: < 0,5 dB,
- directivity: > 18 dB,
- power rating compatible with testing needs.

### 6.3.3 Low loss coaxial cable

The 50  $\Omega$  coaxial cable assembly (including all adaptors, switches, etc.) connecting the dual directional coupler to the transmit antenna shall exhibit a VSWR < 1,1 and transmission loss < 6 dB. Verification shall be performed in accordance with [Annex A](#).

## 6.4 Vector network analyser (VNA)

The VNA shall exhibit the following characteristics:

- frequency range: 1,8 MHz to 6 GHz,
- dynamic range: > 60 dB (IF bandwidth < 3 kHz),
- return loss: > 32 dB,
- transmission loss accuracy: < 0,1 dB,
- minimum number of points: 401,
- IF bandwidth: selected to meet return and transmission loss requirements (typically 1 kHz),
- VNA calibration kit to facilitate TOSM (through, open, short, matched) measurements:
  - termination through: return loss > 35 dB,
  - termination short/open: deviation in nominal phase < 2°,
  - termination match: return loss > 40 dB.

The following characteristics are recommended:

- frequency step: specified by the manufacturer (logarithmic step recommended),
- power level: 0 dBm (recommended value),
- averaging capability (optional),
- it is recommended to use the same connector type to match that of the interconnecting cable assembly and transmit antenna (avoid using adaptors).

## 6.5 Antennas

### 6.5.1 Simulated on-board transmitters

When an OEM antenna is not installed on the vehicle, the antenna(s) described below shall be used.

- For frequency ranges  $\leq 30$  MHz, loaded antennas shall be used. Loaded antennas employ lumped or distributed reactive components with a radiating element physically shorter than quarter wave at resonance. It is recommended to use a “screw-driver” antenna which allows use of a single antenna thus reducing installation time. Use of this antenna also facilitates automation techniques.
- For frequency ranges > 30 MHz, for example, for the very high frequency (VHF) and ultra-high frequency (UHF) bands, quarter wave antennas should be given preference over 5/8 wave antennas, since there are higher skin currents created by quarter wave antennas.



NOTE A screwdriver antenna is a vertical antenna for mobile operation in amateur HF band. It can cover from 10 m to 160 m band according to adjust a centre loading coil remotely. It is named from an electric screwdriver, because of its tuning method by a reversible DC electric motor.

All antennas shall be tuned on the vehicle for minimum voltage standing wave ratio (VSWR, typically less than 2:1) unless otherwise specified in the test plan. As a minimum, the VSWR value shall be measured and recorded with the antenna on the vehicle at the lower and upper band edge and at a middle frequency. See [Annex A](#) for procedures to make these measurements.

### 6.5.2 Simulated portable transmitter

Unless otherwise specified, the simulated portable transmitter antenna shall be a passive antenna. For characteristics of a passive antenna, see [Annex C](#).

## 6.6 Stimulation and monitoring of the vehicle

If remote stimulation and monitoring are required in the test plan, the vehicle shall be operated by actuators which have a minimum effect on the electromagnetic characteristics, e.g. plastic blocks on the push-buttons, pneumatic actuators with plastic tubes.

Connections to monitoring equipment can be accomplished by using fibre-optics or high resistance leads. Other types of leads can be used, but they require extreme care to minimize interactions. The orientation, length and location of such leads shall be carefully documented to ensure repeatability of test results.

Any electrical connection of monitoring equipment to the vehicle can cause malfunctions of the vehicle. Extreme care shall be taken to avoid such an effect.

## 7 Test set-up

### 7.1 Transmitters with antenna outside the vehicle

The test can be performed with test antenna(s) or with the vehicle's OEM antenna, as defined in [6.5.1](#).

When a test antenna is used, the location(s) of the antenna on the vehicle shall be defined in the test plan. If no specific location(s) are agreed between the users of this document, the following location (s) are recommended, as illustrated in [Figure 1](#):

- locations 1 (vehicle roof, front) and 2 (vehicle roof, rear) are the default locations for frequencies  $\geq 30$  MHz. Locations 3 through 8 are optional.
- location 9 (bumper) is the default location for frequencies  $< 30$  MHz. Location 10 is optional.

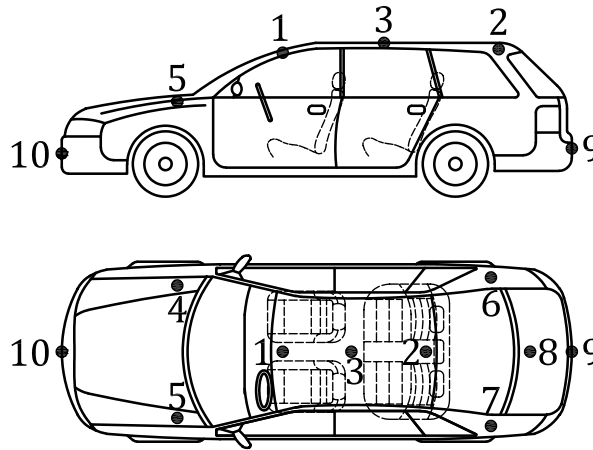

**Key**

- |   |                       |    |                               |
|---|-----------------------|----|-------------------------------|
| 1 | vehicle roof (front)  | 6  | fender (rear, right)          |
| 2 | vehicle roof (rear)   | 7  | fender (rear, left)           |
| 3 | vehicle roof (middle) | 8  | trunk lid (middle)            |
| 4 | fender (front, right) | 9  | bumper (middle) < 30 MHz only |
| 5 | fender (front, left)  | 10 | front bumper < 30 MHz only    |

**Figure 1 — Recommended locations for antennas outside the vehicle**

Examples of test set-up for simulated on-board transmitters are shown in [Figure 2](#) (use of test antenna) and [Figure 3](#) (use of vehicle OEM antenna).

When the vehicle OEM antenna is used, it should be used as it is installed in the vehicle without any change of antenna characteristics (location, VSWR, etc.).

When the vehicle OEM antenna is used for multiple transmitters/receivers frequency, it is advisable not to use a simulated on-board transmitter (with “broadband” amplifier). The amplifier noise level can be sufficient to degrade some vehicle functions, like GPS satellite reception. The validation of such functions (relative to vehicle on-board-transmitter immunity) can only be performed with the vehicle OEM on-board transmitter. In this case, it might be necessary to operate the on-board vehicle transmitter in real conditions. This can be performed by using specific equipment, like a GSM base station simulator.

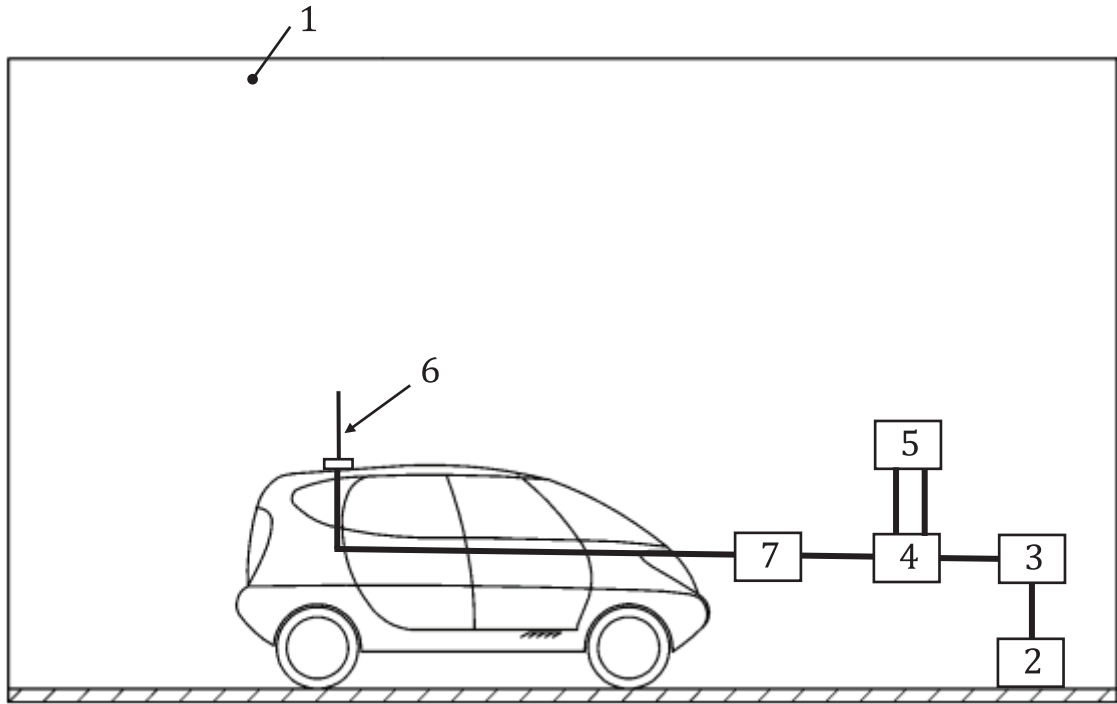

**Key**

- 1 ALSE
- 2 RF signal generator (can be outside test facility)
- 3 power amplifier (can be outside test facility)
- 4 dual directional coupler (can be outside test facility)
- 5 power meter (can be outside test facility)
- 6 test antenna (positions defined in test plan)
- 7 RF choke (see [6.2.1](#))

**Figure 2 — Example of test set-up for simulated on-board transmitter and test antenna**

<https://standards.iteh.ai/catalog/standards/iso/2895eaa2-9a80-47c8-b53a-7911c0b55c22/iso-fdis-11451-3>

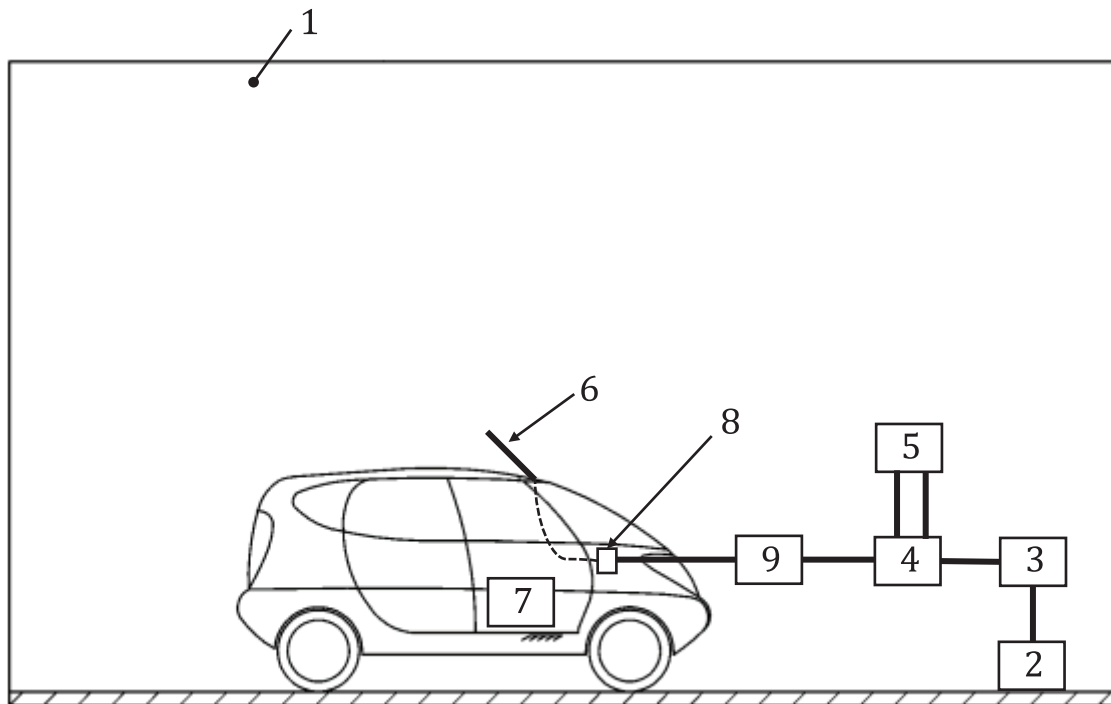

**Key**

- 1 ALSE
- 2 RF signal generator (can be outside test facility)
- 3 power amplifier (can be outside test facility)
- 4 dual directional coupler (can be outside test facility)
- 5 power meter (can be outside test facility)
- 6 vehicle OEM antenna
- 7 on-board transmitter (disconnected from vehicle antenna)
- 8 vehicle antenna cable connector
- 9 RF choke (see 6.2.1)

Standards  
standards.iteh.ai  
Document Preview

ISO/FDIS 11451-3

<https://standards.iteh.ai/catalog/standards/iso/2895eaa2-9a80-47c8-b53a-7911c0b55c22/iso-fdis-11451-3>

**Figure 3 — Example of test set-up for simulated on-board transmitter and vehicle OEM antenna**

## 7.2 Transmitters with antenna inside the vehicle

### 7.2.1 General

The location(s) of a simulated portable transmitter in the vehicle shall be defined in the test plan. If no specific location(s) are agreed between the users of this document, it is recommended to specify places where the portable transmitter can be placed or used. Examples include:

- between front seats,
- on the vehicle’s centre console,
- storage compartments,
- in specified places where a portable transmitter can be placed or used, i.e. between front seats, on the vehicle’s centre console, storage compartments.

### 7.2.2 Simulated portable transmitters

An example of test set-up for simulated portable transmitters is shown in [Figure 4](#).

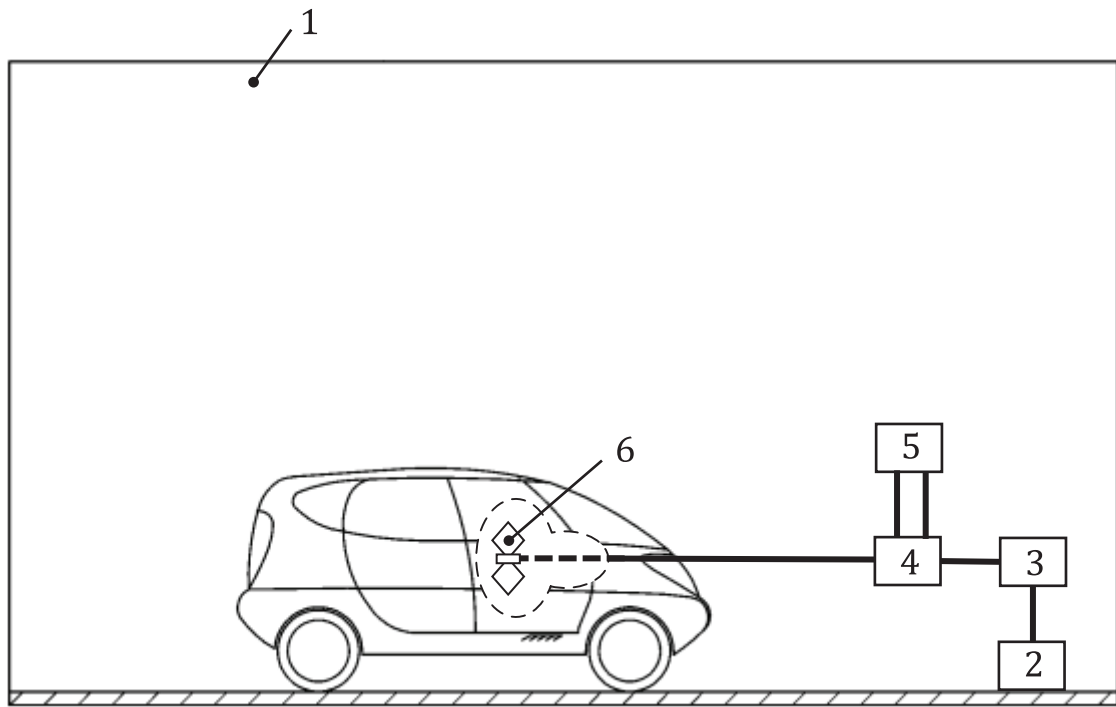
**Key**

- 1 ALSE
- 2 RF signal generator (can be outside test facility)
- 3 power amplifier (can be outside test facility)
- 4 dual directional coupler (can be outside test facility)
- 5 power meter (can be outside test facility)
- 6 test antenna (positions defined in test plan)

**Figure 4 — Example of test set-up for simulated portable transmitters**

[ISO/FDIS 11451-3](https://standards.iteh.ai/catalog/standards/iso/2895eaa2-9a80-47c8-b53a-7911c0b55c22/iso-fdis-11451-3)

<https://standards.iteh.ai/catalog/standards/iso/2895eaa2-9a80-47c8-b53a-7911c0b55c22/iso-fdis-11451-3>

## 8 Test procedure

### 8.1 General

**CAUTION — Hazardous voltages and fields can exist within the test area. Ensure that all requirements for limiting the exposure of humans to RF energy and high voltage are met.**

The general arrangement of vehicle, transmitter(s) and associated equipment represents a standardized test condition. Any deviations from the standard test configuration shall be agreed upon prior to testing and recorded in the test report.

The vehicle shall be made to operate under typical loading and operating conditions. These operating conditions shall be clearly defined in the test plan.

### 8.2 Test plan

Prior to performing the tests, a test plan shall be generated which shall include:

- test set-up;
- frequency range(s) and associated modulation(s);
- duration of transmission;

- antenna location and polarization;
- routing of the coaxial cable to the antenna in the vehicle (for simulated on-board transmitters);
- vehicle mode of operation;
- vehicle monitoring conditions;
- vehicle acceptance criteria;
- simulated portable transmitter antenna location;
- definition of test severity levels;
- definition of signal modulation;
- maximum antenna VSWR value if necessary;
- test report content;
- any special instructions and changes from the standard test.

### 8.3 Test method

#### 8.3.1 Transmitters with antenna outside the vehicle

##### 8.3.1.1 General

The vehicle, antenna(s) and associated equipment are installed as described in [7.1](#).

Test severity levels are based on the antenna configuration used. This means that:

- when using an OEM antenna configuration, the reference parameter is the forward power delivered to the attached OEM antenna cable;
- when using test antennas, the reference parameter is the net power delivered directly to the antenna. See [Annex A](#) for procedures for net power characterization.

In either configuration, measurement of the reflected power serves only as a means to monitor the stability of the signal source during testing.

##### 8.3.1.2 OEM antenna configuration

Testing is based on test setup shown in [Figure 3](#). The test shall at least be performed with this configuration even if tests are also performed with test antenna(s).

Increase the forward power level until the predetermined forward power level is achieved. For modulated signals, the peak conservation principle shall be applied as defined in ISO 11451-1 or alternatively use of wideband peak power sensors (see [6.3](#)). Perform the test at frequencies within the designed bandwidth of the OEM antenna (at least at the lower and upper band edge and at a middle frequency and at frequency steps not greater than those defined in ISO 11451-1).

Continue testing until all frequency bands, modulations, polarizations and antenna locations specified in the test plan are completed.

When required in the test plan, the immunity threshold shall be determined.

##### 8.3.1.3 Test antenna configuration

Testing is based on test setup shown in [Figure 2](#).