**Overview of methods available for
particle-free erosion corrosion testing
in flowing liquids**

iTeh STANDARD PREVIEW
(standards.iteh.ai)

[ISO/PRF TR 16203](https://standards.iteh.ai/catalog/standards/sist/9f563c22-fb8f-48f7-9c0a-2080ee642b1b/iso-prf-tr-16203)

<https://standards.iteh.ai/catalog/standards/sist/9f563c22-fb8f-48f7-9c0a-2080ee642b1b/iso-prf-tr-16203>

PROOF / ÉPREUVE



iTeh STANDARD PREVIEW
(standards.iteh.ai)

ISO/PRF TR 16203

<https://standards.iteh.ai/catalog/standards/sist/9f563c22-fb8f-48f7-9c0a-2080ee642b1b/iso-prf-tr-16203>



COPYRIGHT PROTECTED DOCUMENT

© ISO 2023

All rights reserved. Unless otherwise specified, or required in the context of its implementation, no part of this publication may be reproduced or utilized otherwise in any form or by any means, electronic or mechanical, including photocopying, or posting on the internet or an intranet, without prior written permission. Permission can be requested from either ISO at the address below or ISO's member body in the country of the requester.

ISO copyright office
CP 401 • Ch. de Blandonnet 8
CH-1214 Vernier, Geneva
Phone: +41 22 749 01 11
Email: copyright@iso.org
Website: www.iso.org

Published in Switzerland

Contents

Page

Foreword	iv
Introduction	v
1 Scope	1
2 Normative references	1
3 Terms and definitions	1
4 Principles	1
4.1 Particle-free erosion corrosion.....	1
4.2 Particle-free erosion corrosion test.....	1
4.3 Material loss and observation of surface damage.....	2
5 Test methods	2
5.1 Tests for uniform corrosion.....	2
5.1.1 Rotating cylinder test.....	2
5.1.2 Test in a pipe or channel.....	3
5.2 Tests for nonuniform corrosion.....	3
5.2.1 Rotating disc test.....	3
5.2.2 Test in a pipe or channel with changes in flow cross section.....	4
5.2.3 Jet impingement test.....	5
5.3 Application method of electrochemical measurement.....	5
6 Test condition	8
6.1 General.....	8
6.1.1 Selection of test method.....	8
6.1.2 The effect of flow velocity and test duration in the respective tests.....	8
6.1.3 Wall shear stress.....	9
6.1.4 Selection of damage measuring methods.....	10
6.1.5 Insulation of test specimen.....	10
6.1.6 Use of multiple specimens.....	10
6.1.7 Unit of metal loss.....	10
6.2 Applications and limitations of tests.....	10
Bibliography	13

Foreword

ISO (the International Organization for Standardization) is a worldwide federation of national standards bodies (ISO member bodies). The work of preparing International Standards is normally carried out through ISO technical committees. Each member body interested in a subject for which a technical committee has been established has the right to be represented on that committee. International organizations, governmental and non-governmental, in liaison with ISO, also take part in the work. ISO collaborates closely with the International Electrotechnical Commission (IEC) on all matters of electrotechnical standardization.

The procedures used to develop this document and those intended for its further maintenance are described in the ISO/IEC Directives, Part 1. In particular, the different approval criteria needed for the different types of ISO document should be noted. This document was drafted in accordance with the editorial rules of the ISO/IEC Directives, Part 2 (see www.iso.org/directives).

ISO draws attention to the possibility that the implementation of this document may involve the use of (a) patent(s). ISO takes no position concerning the evidence, validity or applicability of any claimed patent rights in respect thereof. As of the date of publication of this document, ISO had not received notice of (a) patent(s) which may be required to implement this document. However, implementers are cautioned that this may not represent the latest information, which may be obtained from the patent database available at www.iso.org/patents. ISO shall not be held responsible for identifying any or all such patent rights.

Any trade name used in this document is information given for the convenience of users and does not constitute an endorsement.

For an explanation of the voluntary nature of standards, the meaning of ISO specific terms and expressions related to conformity assessment, as well as information about ISO's adherence to the World Trade Organization (WTO) principles in the Technical Barriers to Trade (TBT), see www.iso.org/iso/foreword.html.

This document was prepared by Technical Committee ISO/TC 156, *Corrosion of metals and alloys*.

This second edition cancels and replaces the first edition (ISO/TR 16203:2016), which has been technically revised.

The main changes are as follows:

- In addition to “erosion corrosion”, the description on the “corrosion” under flowing water was added.
- Description on application method of electrochemical measurement was added.

Any feedback or questions on this document should be directed to the user's national standards body. A complete listing of these bodies can be found at www.iso.org/members.html.

Introduction

Particle-free erosion corrosion is a major problem in metallic materials in industries handling liquids flowing rapidly which are corrosive. Specifically, the metallic materials include copper, copper alloys and steels, and the liquids are various types of liquids such as seawater, tap water, industrial water, chemical water (e.g. acid and alkali aqueous solution), waste water, etc. Particle-free erosion corrosion usually leads to rapid metal loss with possibly catastrophic consequences. In order to prevent, mitigate and/or control the problems, it is important to select methods for particle-free erosion corrosion testing. This document provides an overview of the methods available for particle-free erosion corrosion testing in flowing liquids.

iTeh STANDARD PREVIEW
(standards.iteh.ai)

[ISO/PRF TR 16203](https://standards.iteh.ai/catalog/standards/sist/9f563c22-fb8f-48f7-9c0a-2080ee642b1b/iso-prf-tr-16203)

<https://standards.iteh.ai/catalog/standards/sist/9f563c22-fb8f-48f7-9c0a-2080ee642b1b/iso-prf-tr-16203>

Overview of methods available for particle-free erosion corrosion testing in flowing liquids

1 Scope

This document provides an overview of the erosion corrosion tests of materials in single-phase flowing liquids and the test methods available.

2 Normative references

The following documents are referred to in the text in such a way that some or all of their content constitutes requirements of this document. For dated references, only the edition cited applies. For undated references, the latest edition of the referenced document (including any amendments) applies.

ISO 8044, *Corrosion of metals and alloys — Vocabulary*

3 Terms and definitions

For the purposes of this document, the terms and definitions given in ISO 8044 and the following apply.

ISO and IEC maintain terminology databases for use in standardization at the following addresses:

— ISO Online browsing platform: available at <https://www.iso.org/obp>

— IEC Electropedia: available at <https://www.electropedia.org/>

<https://standards.iteh.ai/catalog/standards/sist/9f563c22-fb8f-48f7-9c0a-2080ee642b1b/iso-prf-tr-16203>

3.1 erosion

progressive loss of original material from a solid surface due to mechanical interaction between that surface and a fluid, a multicomponent fluid, or impinging liquid or solid particles

[SOURCE: ASTM G40-22, a^[1]]

3.2

particle-free erosion corrosion

erosion corrosion of metallic materials in single phase flowing liquids free of solid particles and gas bubbles

4 Principles

4.1 Particle-free erosion corrosion

Particle-free erosion corrosion describes the synergistic metal dissolution and mechanical removal of corrosion products formed on a metal surface leading to enhanced corrosion due to distributed or turbulent flow. The details of the predominant phenomena between the dissolution and the mechanical removal are ambiguous.

4.2 Particle-free erosion corrosion test

The conditions in which particle-free erosion corrosion occurs are sensitive to the application, but there are a range of laboratory test methods that have been developed to simulate typical service applications. These test methods can provide a basis for assessing the relative susceptibility of materials to damage development. Particle-free erosion corrosion tests are conducted either by setting up a uniform flow

velocity distribution or turbulent flow mixing. In the former, corrosion damage increases due to the increase in mass transfer in laminar boundary layers as the flow velocity of liquid increases, while in the latter, the corrosion damage increases depending on the strength of turbulent mixing.

4.3 Material loss and observation of surface damage

Material loss by corrosion is detected by measuring mass loss or depth loss of a metal surface. The mass of the sample after the testing or after the stripping the residual corrosion products, compared to its initial mass can provide an indication of the importance of the phenomenon. The depth loss of the sample surface can be also taken into account after the same procedures. The accuracy of corrosion loss is guaranteed by appropriate test specimen size in the mass loss measurement and normalised level of no-corrosion area in the depth measurement. The observations of the corroded surface or the corrosion products are also useful for deducing the corrosion mechanism. Particle-free erosion corrosion behaviour can be observed by electrochemical measurement using a potentiometer, a current meter and a potentiostat. These measurements and observations are taken appropriately according to the purpose of the test.

NOTE The thickness distribution of the corrosion products possibly occurs as same as the damage depth distribution, in the case of nonuniform corrosion. The thickness and property of the corrosion products are probably informative for the mechanisms of corrosion or particle-free erosion corrosion.

5 Test methods

5.1 Tests for uniform corrosion

5.1.1 Rotating cylinder test

A cylindrical specimen electrically insulated at the top and bottom end is used in this test. [Figure 1](#) is a schematic drawing of principle, as for example, Reference [2]. The cylindrical surface is the test surface. It is attached with a shaft at the top end which rotates it around the longitudinal axis in the test solution. The radius of the cylinder is chosen freely, but needs to be constant along the longitudinal distance, so that a uniform distribution of circumferential flow velocity over the entire surface of specimen is achieved. Either rounded insulator or squared-off one at the bottom can be used. This test is widely used for elucidating the effect of flow velocity on the uniform corrosion.

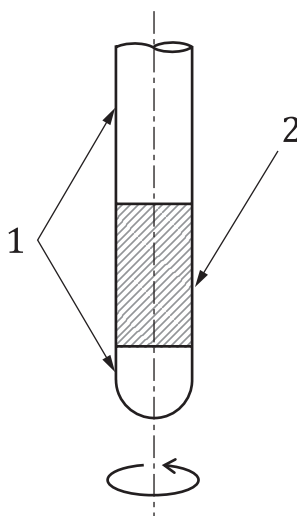

Key

- 1 insulator
- 2 specimen

Figure 1 — Schematic drawing of principle of the rotating cylinder test

5.1.2 Test in a pipe or channel

The pipe specimen installed in the pipeline and the test specimens embedded in the wall of the duct, schematically shown in Figure 2 (a) and (b), as for example, Reference [3] are also used for investigating the effect of flow velocity on uniform corrosion. The specimen surfaces are installed parallel to the flow direction. The upstream flow is possibly rectified or uniform in a pipe. It is not appropriate to put an elbow joint and valve in the upstream flow of about 10 times the diameter. Because of the end effect, the specimen embedded in the pipeline or in the wall of the duct is advantageous over the pipe.

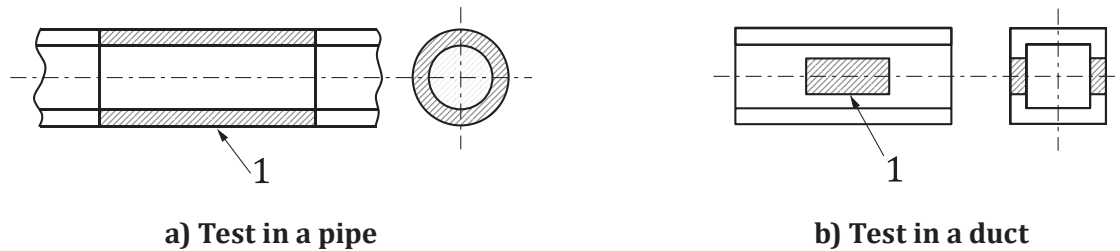

Key

1 specimen

Figure 2 — Schematic drawing of principle of the test

5.2 Tests for nonuniform corrosion

5.2.1 Rotating disc test

In this method, the principle is schematically shown in Figure 3, as for example, Reference [4], a circular and thin disc is located at the underside of the shaft and rotated horizontally around the shaft which is attached vertically at the centre. The disc and the shaft are insulated from each other. The test surface is the underside surface of the disc over which the flow is undisturbed by the shaft and the flow velocity distribution is not uniform but gradually higher velocity towards the periphery. This is the main reason why nonuniform corrosion can be developed in the rotating disc unlike in the rotating cylinder test. However, it is noted that the distribution of flow velocity can deviate from the theoretical calculation because the circumferential flow through the disc rotation is overlapped with the radial secondary flow as is shown in Figure 3 with the curved arrows. The disc also can be located at the upside of the shaft. In that case, the test surface will be the upside of the disc. In either case, the flow pattern on the test surface remains the same.

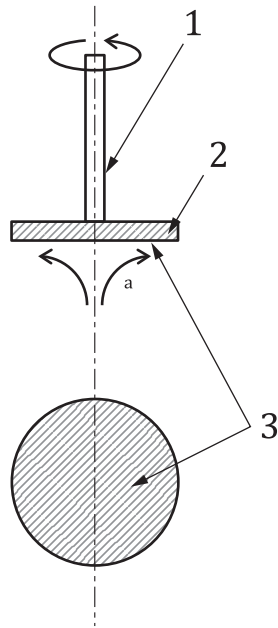

Key

- 1 shaft
- 2 disc specimen
- 3 test surface
- a Radial secondary flow.

iTeh STANDARD PREVIEW
(standards.iteh.ai)

Figure 3 — Schematic drawing of principle of the rotating disc test

ISO/PRF TR 16203

5.2.2 Test in a pipe or channel with changes in flow cross section 48f7-9c0a-2080ee642b1b/iso-prf-tr-16203

A water channel with sudden convergence and divergence in the cross section of liquid flow as shown in [Figure 4](#) is used to produce the nonuniform corrosion induced by a different flow distribution on the inside surface of the channel wall. A stagnant volume of fluid or fixed vortexes is built upstream to reattachment points. Thus, the flow velocity distribution is not uniform along the flow axis (as flow lines schematically shown in [Figure 4](#), as for example, Reference [5]) unlike that without change in the flow cross section, and nonuniform corrosion occurs in this test. Protective corrosion products formed on the surface cannot easily form, so that the corrosion rate can be accelerated in the fluctuated or turbulent mixing flow section. The water channel can be sectioned into thirds using three sets of pipes as shown in [Figure 4](#) b), so that sections 2 and 3 are essentially test specimens.

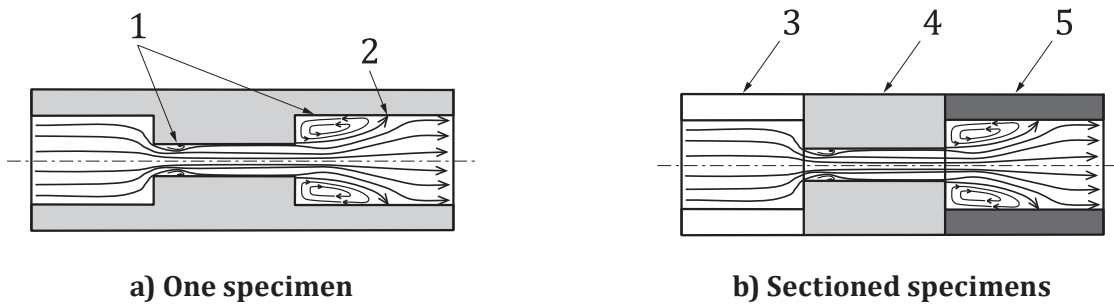

Key

- 1 fluctuated or turbulent mixing flow section
- 2 reattachment point
- 3 section 1
- 4 section 2
- 5 section 3

Figure 4 — Test in flow tunnel with sudden convergence and divergence**5.2.3 Jet impingement test**

Three types of jets, namely, free jet, submerged jet, and jet-in-slit are used as schematically shown in [Figure 5](#), as an example, Reference [6]. The free jet [see [Figure 5 a](#))] is used in conventional impingement tests, where the liquid jet strikes at a right angle to the exposed target material. Narrow ring shape damage is caused by the free jet configuration. The submerged jet [see [Figure 5 b](#))] is a jet submerged in solution where flow velocity in the outer circumference is extremely decreased. Expanded ring shape damage occurs around the narrow ring. When the jet is injected into a narrow gap (see [Figure 5 c](#)) [7]) it is termed jet-in-slit. Wide ring shape damage occurs in the turbulent mixing area created by this test configuration.

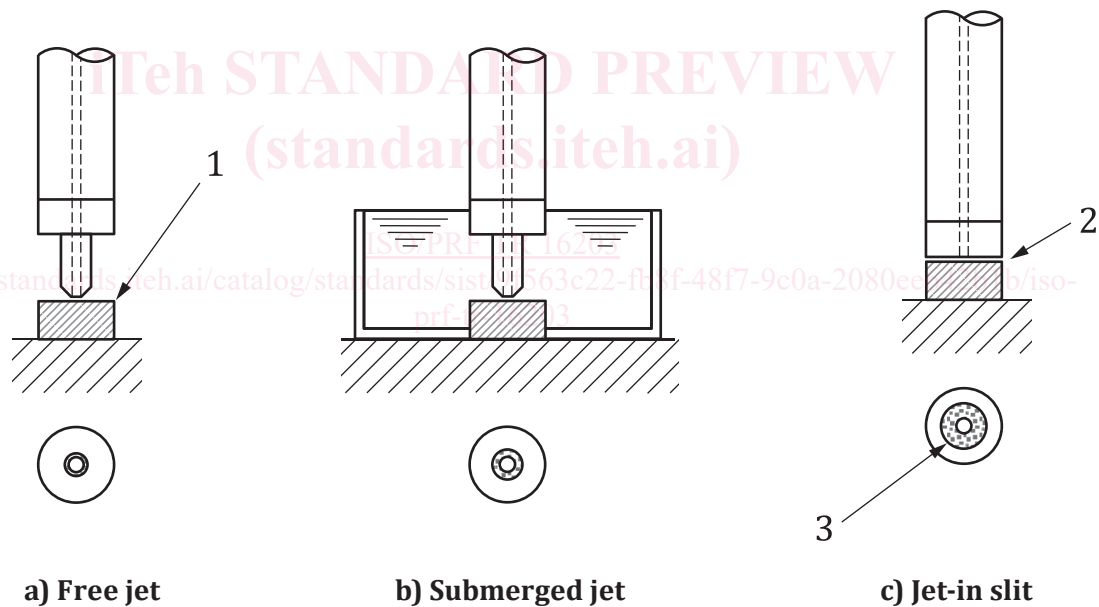
**Key**

- 1 specimen
- 2 narrow gap
- 3 wide ring shape damage

Figure 5 — Schematic drawings of the impinging jets used to evaluate nonuniform corrosion**5.3 Application method of electrochemical measurement**

Electrochemical measurements such as measurements of corrosion potentials, polarisation curves, polarisation resistances, electrochemical impedance spectroscopy (EIS), etc. are also effective methods to evaluate corrosion and particle-free erosion corrosion behaviours and mechanisms in flowing solutions. [8]-[10] For examples, corrosion potentials and/or polarisation curves of metal surfaces in the different flow conditions can be measured to quantify the effects of flow conditions on electrochemical