

~~ISO/DIS 1518-1:2022(E)~~

ISO TC 35/SC 9/WG 31

Date: 2022-06-29 10:18

Paints and varnishes — Determination of scratch resistance — Part 1: Constant-loading method

Peintures et vernis — Détermination de la résistance à la rayure — Partie 1: Méthode à charge constante

Style Definition: Heading 1: Indent: Left: 0 pt, First line: 0 pt, Tab stops: Not at 21.6 pt

Style Definition: Heading 2: Font: Bold, Tab stops: Not at 18 pt

Style Definition: Heading 3: Font: Bold

Style Definition: Heading 4: Font: Bold

Style Definition: Heading 5: Font: Bold

Style Definition: Heading 6: Font: Bold

Style Definition: ANNEX

Style Definition: zzCopyright

Style Definition: AMEND Terms Heading: Font: Bold

Style Definition: AMEND Heading 1 Unnumbered: Font: Bold

Style Definition: Footnote Text

Style Definition: Footnote Reference

Formatted: English (United Kingdom)

Formatted: English (United Kingdom)

Formatted: English (United Kingdom)

iTeh STANDARD PREVIEW
(standards.iteh.ai)

ISO/FDIS 1518-1

<https://standards.iteh.ai/catalog/standards/sist/7fd60302-5ce0-436f-aad5-791e06811495/iso-fdis-1518-1>

~~Edited DIS -
MUST BE USED
FOR FINAL
DRAFT~~

© ISO 2022

All rights reserved. Unless otherwise specified, or required in the context of its implementation, no part of this publication may be reproduced or utilized otherwise in any form or by any means, electronic or mechanical, including photocopying, or posting on the internet or an intranet, without prior written permission. Permission can be requested from either ISO at the address below or ISO's member body in the country of the requester.

ISO ~~copyright office~~Copyright Office

CP 401 • ~~Ch. de Blandonnet 8~~

CH-1214 Vernier, Geneva

Phone: +41 22 749 01 11

Email: ~~copyright@iso.org~~

Email: ~~copyright@iso.org~~

Website: ~~www.iso.org~~www.iso.org

Published in Switzerland.

Formatted: Default Paragraph Font

Formatted: Default Paragraph Font

Formatted: No page break before, Adjust space between Latin and Asian text, Adjust space between Asian text and numbers

Formatted: Adjust space between Latin and Asian text, Adjust space between Asian text and numbers

Formatted: Adjust space between Latin and Asian text, Adjust space between Asian text and numbers

Formatted: English (United Kingdom)

Formatted: English (United Kingdom)

Formatted: Adjust space between Latin and Asian text, Adjust space between Asian text and numbers

Formatted: English (United Kingdom)

iteh STANDARD PREVIEW
(standards.iteh.ai)

ISO/FDIS 1518-1

<https://standards.iteh.ai/catalog/standards/sist/7fd60302-5ce0-436f-aad5-791e06811495/iso-fdis-1518-1>

~~Edited DIS -~~
~~MUST BE USED~~
~~FOR FINAL~~
~~DRAFT~~

© ISO 2022 - All rights reserved

Contents

Foreword.....	iv
1 Scope.....	1
2 Normative references	1
3 Terms and definitions.....	1
4 Principle.....	1
5 Apparatus.....	2
6 Sampling.....	3
7 Test panels.....	4
7.1 Substrate.....	4
7.2 Preparation and coating.....	4
7.3 Drying and conditioning.....	4
7.4 Thickness of coating.....	4
8 Procedure	4
8.1 Test conditions.....	4
8.2 General test procedure.....	5
8.3 Procedure for a single specified load (“pass/fail” test).....	5
8.4 Procedure for determination of the minimum load to cause penetration.....	5
8.5 Evaluation of the scribe.....	5
9 Precision.....	5
10 Test report.....	6
Annex A (informative) Comparison of designation of the scratch styli in the different editions of ISO 1518-1.....	7
Bibliography.....	9Foreword iv
1 Scope.....	1
2 Normative references	1
3 Terms and definitions.....	1
4 Principle.....	2
5 Apparatus.....	2
6 Sampling.....	3
7 Test panels.....	5
7.1 Substrate.....	5
7.2 Preparation and coating.....	5
7.3 Drying and conditioning.....	5
7.4 Thickness of coating.....	5
8 Procedure	5
8.1 Test conditions.....	5

Edited DIS -
MUST BE USED
FOR FINAL
DRAFT

ISO/~~DIS~~FDIS 1518-1:2022(E)

<u>8.2</u>	<u>General test procedure</u>	<u>5</u>
<u>8.3</u>	<u>Procedure for a single specified load (“pass/fail” test).....</u>	<u>6</u>
<u>8.4</u>	<u>Procedure for determination of the minimum load to cause penetration.....</u>	<u>6</u>
<u>8.5</u>	<u>Evaluation of the scribe</u>	<u>6</u>
<u>9</u>	<u>Precision.....</u>	<u>6</u>
<u>10</u>	<u>Test report.....</u>	<u>7</u>
	<u>Annex A (informative) Comparison of the designation of the scratch styli in the different editions of ISO 1518-1</u>	<u>8</u>
	<u>Bibliography.....</u>	<u>9</u>

iTeh STANDARD PREVIEW
(standards.iteh.ai)

ISO/FDIS 1518-1

<https://standards.iteh.ai/catalog/standards/sist/7fd60302-5ce0-436f-aad5-791e06811495/iso-fdis-1518-1>

~~Edited DIS -
MUST BE USED
FOR FINAL
DRAFT~~

© ISO 2022 - All rights reserved

Foreword

ISO (the International Organization for Standardization) is a worldwide federation of national standards bodies (ISO member bodies). The work of preparing International Standards is normally carried out through ISO technical committees. Each member body interested in a subject for which a technical committee has been established has the right to be represented on that committee. International organizations, governmental and non-governmental, in liaison with ISO, also take part in the work. ISO collaborates closely with the International Electrotechnical Commission (IEC) on all matters of electrotechnical standardization.

The procedures used to develop this document and those intended for its further maintenance are described in the ISO/IEC Directives, Part 1. In particular, the different approval criteria needed for the different types of ISO documents should be noted. This document was drafted in accordance with the editorial rules of the ISO/IEC Directives, Part 2 (see www.iso.org/directives).

Attention is drawn to the possibility that some of the elements of this document may be the subject of patent rights. ISO shall not be held responsible for identifying any or all such patent rights. Details of any patent rights identified during the development of the document will be in the Introduction and/or on the ISO list of patent declarations received (see www.iso.org/patents).

Any trade name used in this document is information given for the convenience of users and does not constitute an endorsement.

For an explanation of the voluntary nature of standards, the meaning of ISO specific terms and expressions related to conformity assessment, as well as information about ISO's adherence to the World Trade Organization (WTO) principles in the Technical Barriers to Trade (TBT), see www.iso.org/iso/foreword.html.

This document was prepared by Technical Committee ISO/TC 35, *Paints and varnishes*, Subcommittee SC 9, *General test methods for paints and varnishes*, in collaboration with the European Committee for Standardization (CEN) Technical Committee CEN/TC 139, *Paints and varnishes*, in accordance with the Agreement on technical cooperation between ISO and CEN (Vienna Agreement).

This third edition cancels and replaces the second edition (ISO 1518-1:2019), which has been technically revised.

The main changes are as follows:

- a total new designation of styli has been created, taking into account the type of the stylus already existing in the designation in previous editions;
- ISO 13076 has been added in 8.5 for lighting conditions for the visual evaluation of the scribe;
- Annex A has been added, giving a comparison of the designation of the scratch styli in the different editions of ISO 1518-1;
- The text has been editorially revised and the normative references have been updated.

A list of all parts in the ISO 1518 series can be found on the ISO website.

Edited DIS -
MUST BE USED
FOR FINAL
DRAFT

- Formatted: English (United Kingdom)
- Formatted: Font: Not Italic, English (United Kingdom)
- Formatted: English (United Kingdom)
- Formatted: Font: Not Italic, English (United Kingdom)
- Formatted: English (United Kingdom)

- Formatted: std_publisher
- Formatted: std_docNumber
- Formatted: cite_sec
- Formatted: Default Paragraph Font

ISO/~~DIS~~DIS 1518-1:2022(E)

Any feedback or questions on this document should be directed to the user's national standards body. A complete listing of these bodies can be found at www.iso.org/members.html

iTeh STANDARD PREVIEW
(standards.iteh.ai)

ISO/FDIS 1518-1

<https://standards.iteh.ai/catalog/standards/sist/7fd60302-5ce0-436f-aad5-791e06811495/iso-fdis-1518-1>

~~Edited DIS -
MUST BE USED
FOR FINAL
DRAFT~~

© ISO 2022 - All rights reserved

Paints and varnishes — Determination of scratch resistance — Part 1: Constant-loading method

1 Scope

This document specifies a test method for determining, under defined conditions, the resistance of a single coating or a multi-coat system of paint, varnish or related product to penetration, by scratching with a scratch stylus loaded with a specified load. ~~Penetration of the~~The stylus ~~is penetrates~~ to the substrate, except in the case of a multi-coat system, in which case the stylus can penetrate either to the substrate or to an intermediate coat.

The method specified can be carried out:

- a) either as a “pass/fail” test, by testing with a single specified load applied to the stylus to assess conformity with a particular specification; or
- b) as an assessment test by applying increasing loads to the stylus to determine the minimum load at which the coating is penetrated.

NOTE Neither this document nor ISO 1518-2 specifies a method using a curved stylus, which is specified in ISO 12137. The choice between the three methods depends on the particular practical problem.

2 Normative references

The following documents are referred to in the text in such a way that some or all of their content constitutes requirements of this document. For dated references, only the edition cited applies. For undated references, the latest edition of the referenced document (including any amendments) applies.

ISO 1513, *Paints and varnishes — Examination and preparation of test samples*

ISO 1514, *Paints and varnishes — Standard panels for testing*

ISO 2808, *Paints and varnishes — Determination of film thickness*

ISO 4618, *Paints and varnishes — Terms and definitions*

ISO 13076, *Paints and varnishes — Lighting and procedure for visual assessments of coatings*

ISO 15528, *Paints, varnishes and raw materials for paints and varnishes — Sampling*

3 Terms and definitions

For the purposes of this document, the terms and definitions given in ISO 4618 apply.

ISO and IEC maintain ~~terminological~~terminology databases for use in standardization at the following addresses:

Formatted: Tab stops: Not at 21.6 pt

Formatted: Tab stops: Not at 21.6 pt

Formatted: Adjust space between Latin and Asian text, Adjust space between Asian text and numbers

Formatted: Default Paragraph Font

Formatted: std_docNumber

Formatted: Default Paragraph Font

Formatted: std_docTitle, Font: Not Italic

Formatted: std_docTitle, Font: Not Italic

Formatted: Default Paragraph Font

Formatted: Tab stops: Not at 21.6 pt

Formatted: English (United States)

Formatted: Adjust space between Latin and Asian text, Adjust space between Asian text and numbers

Formatted: English (United States)

Formatted: Font: Times New Roman, 12 pt, English (United States)

- ISO Online browsing platform: available at <https://www.iso.org/obp>
- IEC Electropedia: available at <https://www.electropedia.org/>

4 Principle

A scratch stylus loaded with a specified load is drawn over a coating at a constant speed. The following test parameters are specified:

- the geometry of the stylus tip;
- the range within which the test load can lie and the increments by which it can be increased;
- the procedure by which the stylus is lowered on to the coating;
- the speed at which the stylus travels and the minimum length of the scratch.

The scratch is examined to see if the coating has been penetrated to the extent specified for a single specified test load ("pass/fail" test) or to determine the minimum test load required for penetration.

In some cases, scoring of the surface of the coating is detected. This evaluation should be repeated after 24 h.

5 Apparatus

5.1 **Scratch apparatus**, two versions of which are illustrated in Figure 1 and Figure 2, with the following characteristics:

- The test load acting on the scratch stylus fixed to the load beam can be produced either by a weight attached to the stylus (see Figure 1) or by a weight which slides along a graduated load beam (see Figure 2).
- The test load shall be 1 N to 20 N, adjustable in increments of 0,5 N with a maximum permissible error of 0,2 N.
- The test panel held in a panel holder is moved relative to the stylus by means of a linear actuator driven by a motor. The speed at which the stylus travels shall be (35 ± 5) mm/s and the length of the scratch shall be at least 40 mm. The length of the scratch can affect the result.
- A lowering device with a flat ramp should be used. This brings the stylus smoothly into contact with the coating at the beginning of the movement of the panel holder. The angle of the ramp shall be $(12,5 \pm 2,5)^\circ$.

Some types of apparatus are designed so that the load beam moves and the test panel is fixed. Such types of apparatus may also be used.

5.2 **Scratch stylus HM3,0**, having a hemispherical hard-metal tip of diameter $(3,00 \pm 0,01)$ mm.

5.3 **Scratch stylus HM1,0**, having a hemispherical hard-metal tip of diameter $(1,00 \pm 0,01)$ mm.

5.4 **Scratch stylus HM0,75**, having a hemispherical hard-metal tip of diameter $(0,75 \pm 0,01)$ mm.

5.5 **Scratch stylus HM0,5**, having a hemispherical hard-metal tip of diameter $(0,50 \pm 0,01)$ mm.

Formatted: English (United States)

Formatted: Hyperlink, English (United States)

Formatted: Adjust space between Latin and Asian text, Adjust space between Asian text and numbers, Tab stops: Not at 19.85 pt + 39.7 pt + 59.55 pt + 79.4 pt + 99.25 pt + 119.05 pt + 138.9 pt + 158.75 pt + 178.6 pt + 198.45 pt

Formatted: English (United States)

Formatted: Hyperlink, English (United States)

Formatted: Tab stops: Not at 21.6 pt

Formatted: Tab stops: Not at 21.6 pt

Formatted: Font: Not Bold

iTeh STANDARD PREVIEW

(standards.iteh.ai)

ISO 1518-1:2022
https://standards.iteh.ai/catalog/standards/sis/7-000362-5ccc-436f-aad5-791e06811495/iso-1518-1

Edited DIS -
MUST BE USED
FOR FINAL
DRAFT

5.6 **Scratch stylus SR1,0**, having a hemispherical synthetic-ruby tip of diameter $(1,00 \pm 0,01)$ mm.

5.7 **Scratch stylus SR0,5**, having a hemispherical synthetic-ruby tip of diameter $(0,50 \pm 0,01)$ mm.

In 5.2 to 5.7, "HM" represents the "hard-metal tip" and "SR" represents the "synthetic-ruby tip". The number stands for the diameter of the tip. See Annex A for a comparison of the designation of the scratch styli in the different editions of this document.

5.8 **Indicating device**, based on electrical contact between the stylus and the metallic substrate, to show when the coating has been penetrated.

This device is not suitable for paints containing electrically conducting pigments, for non-metallic substrates or if penetration to an intermediate non-conducting coat is required.

NOTE The indicating device can only be used when certain parts of the scratch apparatus are electrically insulated and a stylus with hard-metal tip is used.

5.9 **Magnifying lens**, with at least $\times 4$ magnification.

6 Sampling

Take a representative sample of the product to be tested (or of each product in the case of a multi-coat system), as described in ISO 15528.

Examine and prepare each sample for testing, as described in ISO 1513.

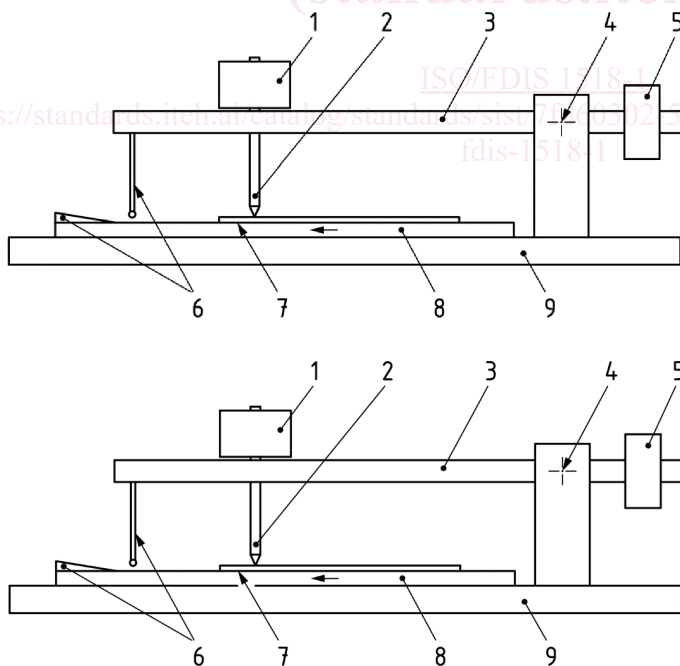

Key

- 1 weight
- 2 scratch stylus
- 3 load beam
- 4 pivot bearing for load beam
- 5 tare weight
- 6 lowering device (ramp and guide pin)
- 7 test panel
- 8 test panel holder (designed to be driven by a motor to move in the direction of the arrow)
- 9 baseplate

Figure 1 — Scratch apparatus — Version with the weight attached to the stylus

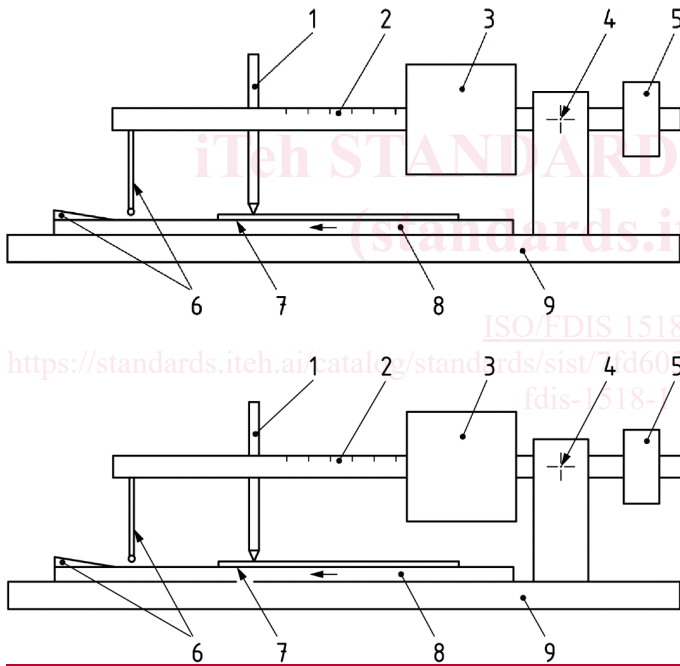

Key

- 1 stylus
- 2 load beam with scale
- 3 sliding weight
- 4 pivot bearing for load beam
- 5 tare weight
- 6 lowering device (ramp and guide pin)
- 7 test panel

~~Edited DIS -
MUST BE USED
FOR FINAL
DRAFT~~