



**International
Standard**

ISO 22915-16

**Industrial trucks — Verification of
stability —**

Part 16:

Pedestrian-propelled trucks

Chariots de manutention — Vérification de la stabilité —

Partie 16: Chariots à conducteur à propulsion manuelle

**Second edition
2024-06**

[ISO 22915-16:2024](https://standards.iteh.ai/catalog/standards/iso/f31124ed-bb0c-48b1-97a4-b6d1e0d2c61c/iso-22915-16-2024)

<https://standards.iteh.ai/catalog/standards/iso/f31124ed-bb0c-48b1-97a4-b6d1e0d2c61c/iso-22915-16-2024>

iTeh Standards
(<https://standards.iteh.ai>)
Document Preview

[ISO 22915-16:2024](https://standards.iteh.ai/catalog/standards/iso/f31124ed-bb0c-48b3-97a4-b6d1e0d2c61c/iso-22915-16-2024)

<https://standards.iteh.ai/catalog/standards/iso/f31124ed-bb0c-48b3-97a4-b6d1e0d2c61c/iso-22915-16-2024>



COPYRIGHT PROTECTED DOCUMENT

© ISO 2024

All rights reserved. Unless otherwise specified, or required in the context of its implementation, no part of this publication may be reproduced or utilized otherwise in any form or by any means, electronic or mechanical, including photocopying, or posting on the internet or an intranet, without prior written permission. Permission can be requested from either ISO at the address below or ISO's member body in the country of the requester.

ISO copyright office
CP 401 • Ch. de Blandonnet 8
CH-1214 Vernier, Geneva
Phone: +41 22 749 01 11
Email: copyright@iso.org
Website: www.iso.org

Published in Switzerland

Contents

	Page
Foreword	iv
1 Scope	1
2 Normative references	1
3 Terms and definitions	1
4 Requirements	1
4.1 General.....	1
4.2 Position of the truck on the tilt table.....	2
4.2.1 General.....	2
4.2.2 Load and steer axles.....	2
4.2.3 Tests 1, 2, 4, 7 and 8 for longitudinal direction of test.....	2
4.2.4 Tests 3, 5, 6, 9 and 10 for lateral direction of test.....	2
5 Verification of stability	3
5.1 Dynamic test — Platform trucks.....	3
5.2 Tilt table tests.....	3
Bibliography	10

iTeh Standards
(<https://standards.itih.ai>)
Document Preview

[ISO 22915-16:2024](https://standards.itih.ai/catalog/standards/iso/f31124ed-bb0c-48b3-97a4-b6d1e0d2c61c/iso-22915-16-2024)

<https://standards.itih.ai/catalog/standards/iso/f31124ed-bb0c-48b3-97a4-b6d1e0d2c61c/iso-22915-16-2024>

Foreword

ISO (the International Organization for Standardization) is a worldwide federation of national standards bodies (ISO member bodies). The work of preparing International Standards is normally carried out through ISO technical committees. Each member body interested in a subject for which a technical committee has been established has the right to be represented on that committee. International organizations, governmental and non-governmental, in liaison with ISO, also take part in the work. ISO collaborates closely with the International Electrotechnical Commission (IEC) on all matters of electrotechnical standardization.

The procedures used to develop this document and those intended for its further maintenance are described in the ISO/IEC Directives, Part 1. In particular, the different approval criteria needed for the different types of ISO document should be noted. This document was drafted in accordance with the editorial rules of the ISO/IEC Directives, Part 2 (see www.iso.org/directives).

ISO draws attention to the possibility that the implementation of this document may involve the use of (a) patent(s). ISO takes no position concerning the evidence, validity or applicability of any claimed patent rights in respect thereof. As of the date of publication of this document, ISO had not received notice of (a) patent(s) which may be required to implement this document. However, implementers are cautioned that this may not represent the latest information, which may be obtained from the patent database available at www.iso.org/patents. ISO shall not be held responsible for identifying any or all such patent rights.

Any trade name used in this document is information given for the convenience of users and does not constitute an endorsement.

For an explanation of the voluntary nature of standards, the meaning of ISO specific terms and expressions related to conformity assessment, as well as information about ISO's adherence to the World Trade Organization (WTO) principles in the Technical Barriers to Trade (TBT), see www.iso.org/iso/foreword.html.

This document was prepared by Technical Committee ISO/TC 110, *Industrial trucks*, Subcommittee SC 2, *Safety of powered industrial trucks*.

This second edition cancels and replaces the first edition (ISO 22915-16:2014), which has been technically revised.

The main changes are as follows:

- in the Scope, for scissor-lift pallet trucks with lift heights up to 1 000 mm, the rated capacity has been increased to 1 500 kg;
- in the Scope, "straddle" has been replaced with "stacker" and "platform stacker" has been replaced by "pallet stacker" (in accordance with ISO 5053-1);
- in [Table 3](#), the figure at the bottom right for lateral test (i.e., non-articulated, non-sprung castor wheel axle turned towards load axle C–C and parallel with X–Y), has been updated.

A list of all parts in the ISO 22915 series can be found on the ISO website.

Any feedback or questions on this document should be directed to the user's national standards body. A complete listing of these bodies can be found at www.iso.org/members.html.

Industrial trucks — Verification of stability —

Part 16: Pedestrian-propelled trucks

1 Scope

This document specifies tests for verifying the stability of pedestrian-propelled trucks.

It is applicable to:

- stacker, pallet and pallet stacker trucks with capacities not exceeding 1 000 kg, with manual or battery-powered lift;
- scissor-lift pallet trucks with lift heights up to 1 000 mm and rated capacity up to 1 500 kg, with manual or battery-powered lift;
- platform trucks.

It also applies to trucks operating under the same conditions when equipped with load-handling attachments.

It is not applicable to trucks with retractable devices such as a retractable mast or retractable fork carrier.

2 Normative references

The following documents are referred to in the text in such a way that some or all of their content constitutes requirements of this document. For dated references, only the edition cited applies. For undated references, the latest edition of the referenced document (including any amendments) applies.

ISO 3691-5:2014, *Industrial trucks — Safety requirements and verification — Part 5: Pedestrian-propelled trucks*

ISO 5053-1, *Industrial trucks — Vocabulary — Part 1: Types of industrial trucks*

ISO 22915-1, *Industrial trucks — Verification of stability — Part 1: General*

3 Terms and definitions

For the purposes of this document, the terms and definitions given in ISO 5053-1 and ISO 22915-1 apply.

ISO and IEC maintain terminology databases for use in standardization at the following addresses:

- ISO Online browsing platform: available at <https://www.iso.org/obp>
- IEC Electropedia: available at <https://www.electropedia.org/>

4 Requirements

4.1 General

ISO 22915-1 shall apply.

4.2 Position of the truck on the tilt table

4.2.1 General

All tests shall be carried out with castors and swivelling wheels, when fitted, in the position of least stability (see [Tables 1, 2 and 3](#)).

4.2.2 Load and steer axles

The load and steer axles are defined by [Figure 1](#).

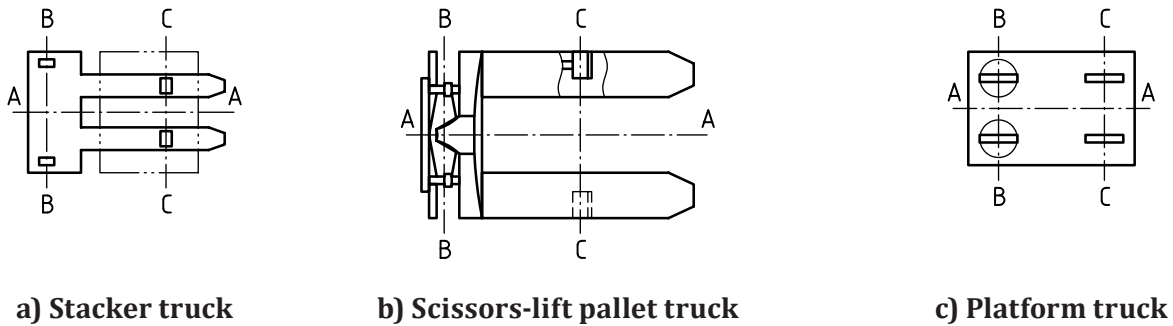

Key

- A-A longitudinal centre plane of the truck
- B-B steer axle
- C-C load axle

Figure 1 — Load and steer axles

4.2.3 Tests 1, 2, 4, 7 and 8 for longitudinal direction of test

The truck shall be positioned on the tilt table with the steer axle B-B and the load axle C-C parallel to the tilt axis X-Y of the tilt table.

4.2.4 Tests 3, 5, 6, 9 and 10 for lateral direction of test

The truck shall be positioned on the tilt table with the line M-N parallel to the tilt axis X-Y of the tilt table.

Point M is defined as follows.

- a) For trucks with a single or dual non-sprung castor wheel, point M shall be the vertical projection onto the tilt table of the point of intersection between the centreline of the castor wheel axle and the centreline of the castor wheel width (single) or the centreline between the two castor wheels (dual), with the centreline of the castor wheel axle being positioned parallel to X-Y. The castor wheel shall be turned away from X-Y to the orientation that produces minimum stability.
- b) For trucks having non-articulating dual steer wheels, point M is the vertical projection onto the tilt table of the point of intersection between the centreline of the steer axle and the midpoint between the two steer wheels, with the axle of the steer wheels positioned parallel to the tilt axis X-Y or at any other orientation that produces minimum stability.
- c) For trucks with stabilizers, point M is the vertical projection onto the tilt table of the point of symmetry of the stabilizer contact surface.

As shown in [Table 1, 2 and 3](#), point N is defined as the centre point of the area of contact between the tilt table surface and the load wheel closest to the tilt axis, X-Y, of the tilt table.