**Paints and varnishes — Pendulum
damping test**

Peintures et vernis — Essai d'amortissement du pendule

iTeh STANDARD PREVIEW
(standards.iteh.ai)

ISO 1522:2022

<https://standards.iteh.ai/catalog/standards/sist/bb19c97e-ece3-4f3a-90b3-ad6bce6c3133/iso-1522-2022>



iTeh STANDARD PREVIEW
(standards.iteh.ai)

ISO 1522:2022

<https://standards.iteh.ai/catalog/standards/sist/bb19c97e-ece3-4f3a-90b3-ad6bce6c3133/iso-1522-2022>



COPYRIGHT PROTECTED DOCUMENT

© ISO 2022

All rights reserved. Unless otherwise specified, or required in the context of its implementation, no part of this publication may be reproduced or utilized otherwise in any form or by any means, electronic or mechanical, including photocopying, or posting on the internet or an intranet, without prior written permission. Permission can be requested from either ISO at the address below or ISO's member body in the country of the requester.

ISO copyright office
CP 401 • Ch. de Blandonnet 8
CH-1214 Vernier, Geneva
Phone: +41 22 749 01 11
Email: copyright@iso.org
Website: www.iso.org

Published in Switzerland

Contents

	Page
Foreword	iv
Introduction	v
1 Scope	1
2 Normative references	1
3 Terms and definitions	1
4 Principle	1
5 Apparatus	1
6 Sampling	4
7 Test panels	4
7.1 Substrate.....	4
7.2 Preparation and coating.....	4
7.3 Drying and conditioning.....	4
7.4 Thickness of coating.....	4
8 Procedure	4
8.1 Calibration of the instruments.....	4
8.2 Ambient conditions.....	5
8.3 Determination of pendulum damping time.....	5
9 Expression of results	5
10 Precision	5
10.1 König pendulum.....	5
10.1.1 General.....	5
10.1.2 Repeatability limit, r	5
10.1.3 Reproducibility limit, R	5
10.2 Persoz pendulum.....	6
10.2.1 Repeatability limit, r	6
10.2.2 Reproducibility limit, R	6
11 Supplementary test conditions	6
12 Test report	6
Annex A (normative) Calibration of the König pendulum	8
Annex B (normative) Calibration of the Persoz pendulum	9
Bibliography	10

Foreword

ISO (the International Organization for Standardization) is a worldwide federation of national standards bodies (ISO member bodies). The work of preparing International Standards is normally carried out through ISO technical committees. Each member body interested in a subject for which a technical committee has been established has the right to be represented on that committee. International organizations, governmental and non-governmental, in liaison with ISO, also take part in the work. ISO collaborates closely with the International Electrotechnical Commission (IEC) on all matters of electrotechnical standardization.

The procedures used to develop this document and those intended for its further maintenance are described in the ISO/IEC Directives, Part 1. In particular, the different approval criteria needed for the different types of ISO documents should be noted. This document was drafted in accordance with the editorial rules of the ISO/IEC Directives, Part 2 (see www.iso.org/directives).

Attention is drawn to the possibility that some of the elements of this document may be the subject of patent rights. ISO shall not be held responsible for identifying any or all such patent rights. Details of any patent rights identified during the development of the document will be in the Introduction and/or on the ISO list of patent declarations received (see www.iso.org/patents).

Any trade name used in this document is information given for the convenience of users and does not constitute an endorsement.

For an explanation of the voluntary nature of standards, the meaning of ISO specific terms and expressions related to conformity assessment, as well as information about ISO's adherence to the World Trade Organization (WTO) principles in the Technical Barriers to Trade (TBT), see www.iso.org/iso/foreword.html.

This document was prepared by Technical Committee ISO/TC 35, *Paints and varnishes*, Subcommittee SC 9, *General test methods for paints and varnishes*, in collaboration with the European Committee for Standardization (CEN) Technical Committee CEN/TC 139, *Paints and varnishes*, in accordance with the Agreement on technical cooperation between ISO and CEN (Vienna Agreement).

This fourth edition cancels and replaces the third edition (ISO 1522:2006), which has been technically revised.

The main changes are as follows:

- [Clause 3](#) “Terms and definitions” has been added.
- The recommendation of using metal or glass panels has been removed from [7.1](#) because the test method is also usable for other substrate materials, e.g. plastics.
- The precision statement of the König Pendulum in [10.1](#) has been corrected reflecting the test conditions and results of the interlaboratory comparison in 2006.
- In [5.1.3](#) and in [B.3.2](#) the tolerance for the time for the amplitude of swing to decrease from 12° to 4° has been changed back to ±10 s, as it was in the second edition (ISO 1522:1998).
- The calibration of the pendulum has been added with a test for deformation.
- The text has been editorially revised and the normative references have been updated.

Any feedback or questions on this document should be directed to the user's national standards body. A complete listing of these bodies can be found at www.iso.org/members.html.

Introduction

This document considers in detail two test procedures for pendulum damping tests, König and Persoz. The instruments embody the same principle, i.e. that the amplitude of oscillation of a pendulum touching a surface decreases more rapidly the softer the surface, but differ in respect of dimensions, period and amplitude of oscillation.

The interaction between the pendulum and the paint film is complex, depending as it does on both elastic and viscoelastic properties, and it is not possible to establish a general relationship between results obtained by the two tests. Therefore, only one type of pendulum should be used in a given series of measurements of damping time.

The following considerations may serve as a guide when considering which pendulum may offer an advantage for a particular purpose.

- a) On surfaces with a low coefficient of friction, the Persoz pendulum may skid, which would invalidate results; however, this occurs only rarely with paints and varnishes.
- b) It should be noted that both instruments reflect the sensitivity of the physical properties of a paint to its environment, and the test therefore should be under controlled conditions of temperature and humidity and in the absence of draughts. The thickness of the paint film and the nature of the substrate may also affect the damping times.

iTeh STANDARD PREVIEW
(standards.iteh.ai)

ISO 1522:2022

<https://standards.iteh.ai/catalog/standards/sist/bb19c97e-ece3-4f3a-90b3-ad6bce6c3133/iso-1522-2022>

Paints and varnishes — Pendulum damping test

1 Scope

This document specifies two methods of carrying out a pendulum damping test on a coating of paint, varnish or other related products. It is applicable to single coatings and to multicoat systems.

2 Normative references

The following documents are referred to in the text in such a way that some or all of their content constitutes requirements of this document. For dated references, only the edition cited applies. For undated references, the latest edition of the referenced document (including any amendments) applies.

ISO 1513, *Paints and varnishes — Examination and preparation of test samples*

ISO 1514, *Paints and varnishes — Standard panels for testing*

ISO 2808, *Paints and varnishes — Determination of film thickness*

ISO 4618, *Paints and varnishes — Terms and definitions*

ISO 15528, *Paints, varnishes and raw materials for paints and varnishes — Sampling*

3 Terms and definitions

For the purposes of this document, the terms and definitions given in ISO 4618 apply.

ISO and IEC maintain terminology databases for use in standardization at the following addresses:

- ISO Online browsing platform: available at <https://www.iso.org/obp>
- IEC Electropedia: available at <https://www.electropedia.org/>

4 Principle

A pendulum resting on a coating surface is set into oscillation and the time for the oscillation amplitude to decrease by an amount specified in this document is measured. The shorter the damping time, the lower the hardness.

5 Apparatus

5.1 Pendulum

5.1.1 Both the pendulums, as described in [5.1.2](#) and [5.1.3](#), comprise an open framework connected by a cross-bar on the under face of which two balls are inset to serve as the fulcrum, the lower end of the framework being formed into a pointer. The two pendulums differ in shape, mass, swinging time and other details, as described in [5.1.2](#) and [5.1.3](#).

The pendulum shall be used away from draughts and vibrations.

The use of a protective enclosure is recommended.

5.1.2 The König pendulum (see Figure 1) rests on two tungsten-carbide balls of $(5 \pm 0,005)$ mm diameter, of hardness $(1\ 600 \pm 32)$ HV 30¹⁾, and $(30 \pm 0,2)$ mm apart and is counterpoised (to adjust the natural frequency of oscillation) by means of a weight sliding on a vertical rod attached to the cross-bar. On a polished plate-glass panel, the period of oscillation shall be $(1,40 \pm 0,02)$ s and the time for damping from a 6° displacement to a 3° displacement shall be (250 ± 10) s. The total mass of the pendulum shall be $(200 \pm 0,2)$ g.

Dimensions in millimetres

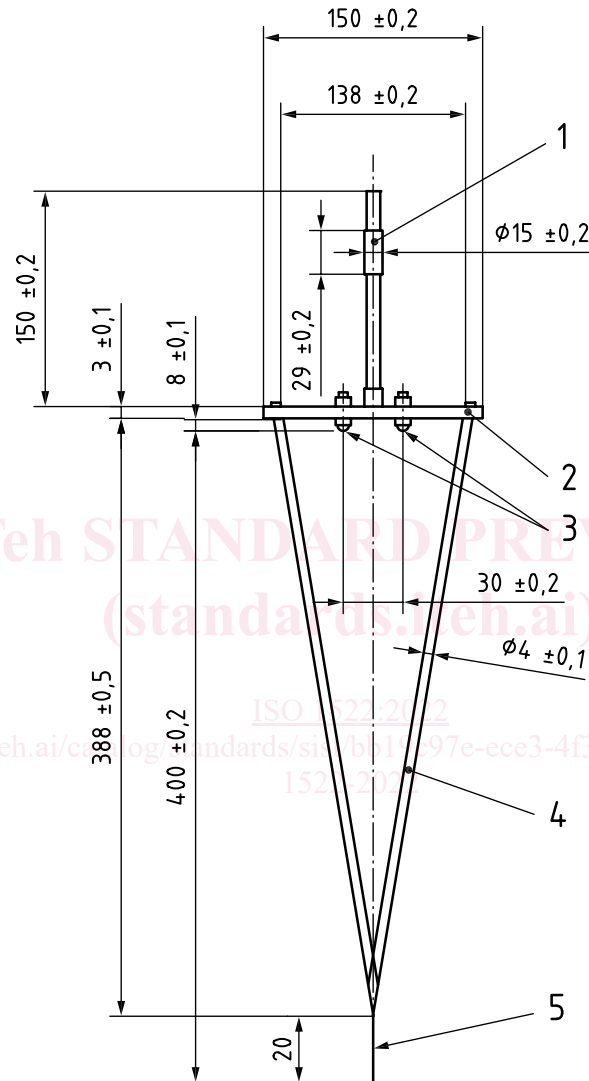

Key

- | | |
|-----------------------------------|---------|
| 1 counterpoise (adjustable) | 4 frame |
| 2 cross-bar, width $12 \pm 0,1$ | 5 tip |
| 3 ball, $\varnothing 5 \pm 0,005$ | |

Figure 1 — König pendulum

5.1.3 The Persoz pendulum (see Figure 2) rests on two tungsten-carbide balls of $(8 \pm 0,005)$ mm diameter, of hardness $(1\ 600 \pm 32)$ HV 30¹⁾, and (50 ± 1) mm apart. A counterpoise is not provided. On a polished plate-glass panel, the period of oscillation shall be $(1 \pm 0,01)$ s and the time for damping from a 12° displacement to a 4° displacement on the same substrate shall be (430 ± 10) s. The total mass of the

1) HV: Vickers hardness determined according to ISO 6507-1.

pendulum shall be $(500 \pm 0,1)$ g and its centre of gravity at rest shall be $(60 \pm 0,1)$ mm below the plane of the fulcrum, the pointer tip being $(400 \pm 0,2)$ mm below the plane of the fulcrum.

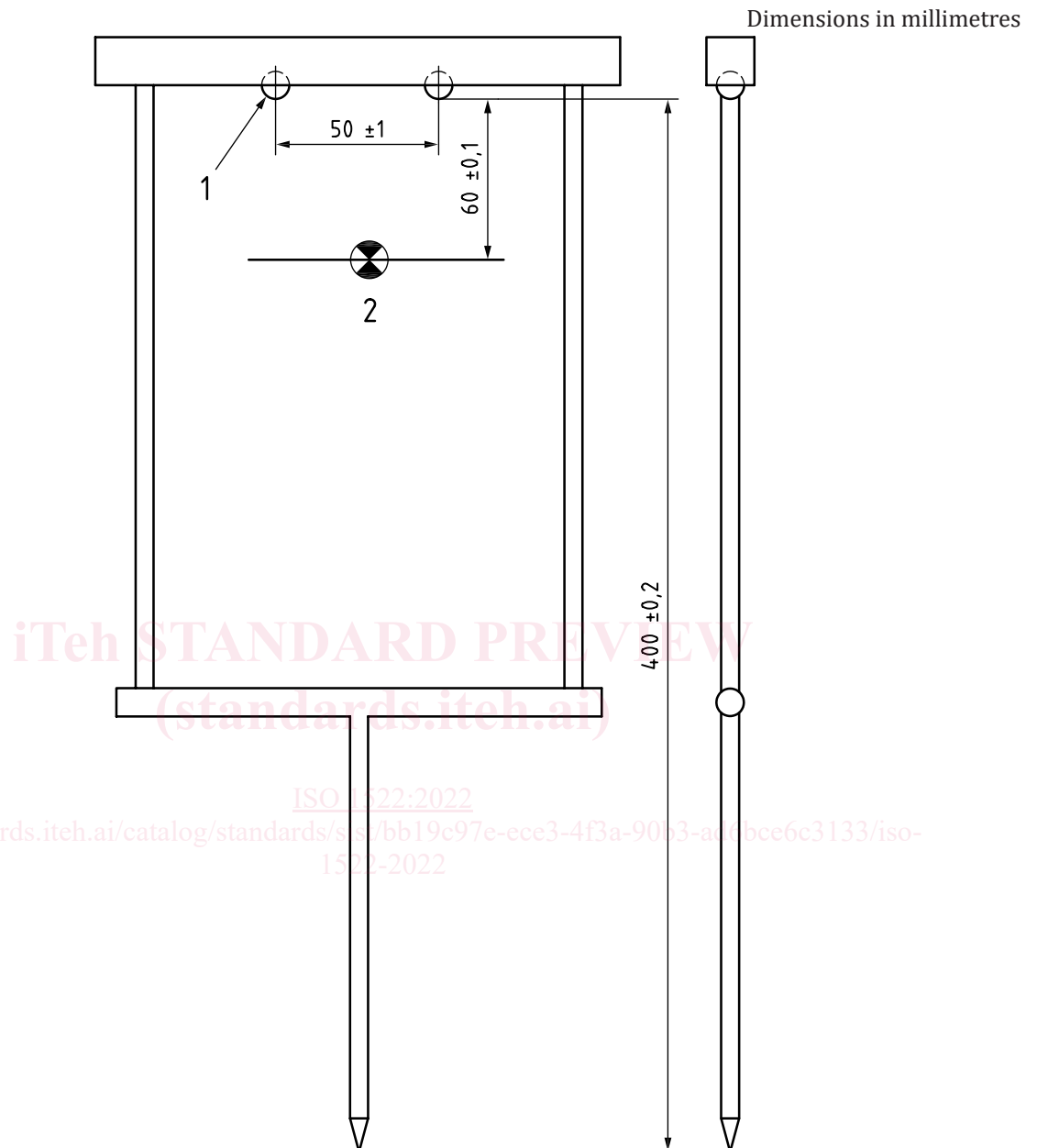

Figure 2 — Persoz pendulum

5.2 Instrument stand

The stand for supporting test panel and pendulum is common to both pendulums and comprises a heavy supported vertical rod to which is attached a horizontal table with a flat working surface, the dimensions of which may conveniently be 95 mm × 110 mm and not less than 10 mm thick. The stand also has a stirrup to support the pendulum away from the table and a mechanism for shock-free lowering of the pendulum on to the test panel.

5.3 Scale

The front of the stand shall be marked to show angular displacement of the pendulum from a centre point, indicating the rest position of the pendulum, through 6° and 3° for a König pendulum and through 12° and 4° for a Persoz pendulum. The scale may be moved horizontally, and locked in position so that the zero marking and the test position of the pendulum tip coincide. This scale may be marked on a mirror, or a mirror may be placed behind the scale, to assist in eliminating parallax errors during observation.

5.4 **Stopwatch**, or other timing device, for timing the oscillation damping of the pendulum.

5.5 **Polished plate (float) glass panel**, for calibrating the pendulum.

6 Sampling

Take a representative sample of the product to be tested (or of each product in the case of a multicoat system), as specified in ISO 15528.

Examine and prepare each sample for testing, as specified in ISO 1513.

7 Test panels

7.1 Substrate

Select the substrate from one of those specified in ISO 1514, ensuring that the panels are plane, rigid and free from distortion. The test panel shall have dimensions of approximately 100 mm × 100 mm × 5 mm.

7.2 Preparation and coating

Unless otherwise specified, prepare each test panel in accordance with ISO 1514 and then coat it by the specified method with the product or system under test. The test coating shall then be smooth and free from surface irregularities.

7.3 Drying and conditioning

Dry (or stove) and age (if applicable) each coated test panel for the specified time and under the conditions specified by contract between the interested parties. Before testing, condition the test panels at a temperature of (23 ± 2) °C and relative humidity of (50 ± 5) %, unless otherwise specified, for a minimum of 16 h.

Fingerprints, dust or other contamination on the surface results in lower accuracy. The coated panels should therefore be stored and handled in an appropriate way.

7.4 Thickness of coating

Determine the thickness, in micrometres, of the dried coating by one of the procedures specified in ISO 2808. The minimum dry-film thickness of the coating should preferably be 30 µm.

8 Procedure

8.1 Calibration of the instruments

Calibrate the instrument using the procedures specified in [Annexes A](#) and [B](#).