**Technical product documentation
(TPD) — General principles of
representation —**

**Part 3:
Views, sections and cuts**

*Documentation technique de produits (TPD) — Principes généraux de
représentation —
Partie 3: Vues, sections et coupes*

ISO 128-3:2022

<https://standards.iteh.ai/catalog/standards/sist/75d888a5-6e9a-4fac-9120-8f2dff20899/iso-128-3-2022>



iTeh STANDARD PREVIEW
(standards.iteh.ai)

ISO 128-3:2022

<https://standards.iteh.ai/catalog/standards/sist/75d888a5-6e9a-4fac-9120-8f2dfc20899/iso-128-3-2022>



COPYRIGHT PROTECTED DOCUMENT

© ISO 2022

All rights reserved. Unless otherwise specified, or required in the context of its implementation, no part of this publication may be reproduced or utilized otherwise in any form or by any means, electronic or mechanical, including photocopying, or posting on the internet or an intranet, without prior written permission. Permission can be requested from either ISO at the address below or ISO's member body in the country of the requester.

ISO copyright office
CP 401 • Ch. de Blandonnet 8
CH-1214 Vernier, Geneva
Phone: +41 22 749 01 11
Email: copyright@iso.org
Website: www.iso.org

Published in Switzerland

Contents

| | Page |
|---|-----------|
| Foreword..... | iv |
| Introduction..... | v |
| 1 Scope..... | 1 |
| 2 Normative references..... | 1 |
| 3 Terms and definitions..... | 1 |
| 4 Basic conventions for views..... | 2 |
| 4.1 General information on views..... | 2 |
| 4.2 Choice of views..... | 3 |
| 4.3 Partial views..... | 3 |
| 4.4 Simplified view of symmetrical parts..... | 4 |
| 4.5 First-angle projection method..... | 4 |
| 4.6 First-angle projection method views..... | 4 |
| 4.7 First-angle projection graphical symbol..... | 5 |
| 4.8 Third-angle projection method..... | 5 |
| 4.9 Third-angle projection method views..... | 5 |
| 4.10 Third-angle projection graphical symbol..... | 6 |
| 4.11 Other projection methods..... | 6 |
| 4.12 Enlarged features..... | 6 |
| 5 Reference indication for views and enlarged features..... | 7 |
| 5.1 General..... | 7 |
| 5.2 Details of the reference indication..... | 7 |
| 5.3 Examples of indication..... | 8 |
| 6 General information on cuts and sections..... | 9 |
| 6.1 General..... | 9 |
| 6.2 Indication of cuts and sections..... | 9 |
| 6.2.1 Cutting plane..... | 9 |
| 6.2.2 Identification of the cutting plane..... | 9 |
| 6.2.3 Identification of the cuts and sections..... | 9 |
| 6.2.4 Reference indication for cuts and sections..... | 10 |
| 6.3 Sections revolved in the relevant view..... | 11 |
| 6.4 Cuts/sections of symmetrical parts..... | 12 |
| 6.5 Local cuts/sections..... | 12 |
| 7 Basic conventions for representing areas on cuts and sections..... | 13 |
| 7.1 General information on cuts and sections..... | 13 |
| 7.2 Hatching..... | 13 |
| 7.3 Shading or toning..... | 14 |
| 7.4 Extra-wide continuous outlines..... | 15 |
| 7.5 Thin sections..... | 15 |
| 7.6 Thin adjacent sections..... | 15 |
| 7.7 Specific materials..... | 16 |
| Annex A (normative) Graphical symbols..... | 17 |
| Annex B (informative) Former practices..... | 20 |
| Annex C (normative) Views on mechanical engineering technical drawings..... | 22 |
| Annex D (normative) Sections on mechanical engineering technical drawings..... | 34 |
| Annex E (normative) Projection methods in building technical drawings..... | 39 |
| Annex F (normative) Representation of views, sections and cuts on construction drawings..... | 41 |
| Bibliography..... | 48 |

Foreword

ISO (the International Organization for Standardization) is a worldwide federation of national standards bodies (ISO member bodies). The work of preparing International Standards is normally carried out through ISO technical committees. Each member body interested in a subject for which a technical committee has been established has the right to be represented on that committee. International organizations, governmental and non-governmental, in liaison with ISO, also take part in the work. ISO collaborates closely with the International Electrotechnical Commission (IEC) on all matters of electrotechnical standardization.

The procedures used to develop this document and those intended for its further maintenance are described in the ISO/IEC Directives, Part 1. In particular, the different approval criteria needed for the different types of ISO documents should be noted. This document was drafted in accordance with the editorial rules of the ISO/IEC Directives, Part 2 (see www.iso.org/directives).

Attention is drawn to the possibility that some of the elements of this document may be the subject of patent rights. ISO shall not be held responsible for identifying any or all such patent rights. Details of any patent rights identified during the development of the document will be in the Introduction and/or on the ISO list of patent declarations received (see www.iso.org/patents).

Any trade name used in this document is information given for the convenience of users and does not constitute an endorsement.

For an explanation of the voluntary nature of standards, the meaning of ISO specific terms and expressions related to conformity assessment, as well as information about ISO's adherence to the World Trade Organization (WTO) principles in the Technical Barriers to Trade (TBT), see www.iso.org/iso/foreword.html.

This document was prepared by Technical Committee ISO/TC 10, *Technical product documentation*, in collaboration with the European Committee for Standardization (CEN) Technical Committee CEN/SS F01, *Technical drawings*, in accordance with the Agreement on technical cooperation between ISO and CEN (Vienna Agreement).

This second edition cancels and replaces the first edition (ISO 128-3:2020), of which it constitutes a minor revision, and ISO 128-43:2015. The changes are as follows:

- [Clause 2](#): reference to ISO 10209 has been updated;
- [Figures A.3, A.4, A.5, B.4, D.10, E.1](#) and [E.2](#) have been redrawn to be consistent with the text;
- minor editorial changes.

A list of all parts in the ISO 128 series can be found on the ISO website.

Any feedback or questions on this document should be directed to the user's national standards body. A complete listing of these bodies can be found at www.iso.org/members.html.

Introduction

This document contains generally applicable rules for the presentation of views, sections and cuts in all kinds of technical product documentation. The first-angle projection method (formerly referred to as method E) and the third-angle projection method (formerly referred to as method A) are described in more detail in ISO 5456-2.

All figures in this document, excluding [Figure 1](#), [Figure 6](#) and [Figure 7](#), have been drawn in first-angle projection method unless other methods are stated. It should be understood that third-angle projection or other methods could have been used equally well without prejudice to the principles established.

The application of views, sections and cuts within drawings of special technical fields varies considerably. Therefore, rules of application specific to technical fields are given in [Annexes C, D, E](#) and [F](#).

iTeh STANDARD PREVIEW
(standards.iteh.ai)

[ISO 128-3:2022](#)

<https://standards.iteh.ai/catalog/standards/sist/75d888a5-6e9a-4fac-9120-8f2dff20899/iso-128-3-2022>

Technical product documentation (TPD) — General principles of representation —

Part 3: Views, sections and cuts

1 Scope

This document specifies the general principles for presenting views, sections and cuts applicable to various kinds of technical drawings (e.g. mechanical, electrical, architectural, civil engineering), following the orthographic projection methods specified in ISO 5456-2. Views and sections for shipbuilding technical drawings are discussed in ISO 128-15. Views and sections for 3D models are discussed in ISO 16792.

Attention has also been given in this document to the requirements of reproduction, including microcopying in accordance with ISO 6428.

2 Normative references

The following documents are referred to in the text in such a way that some or all of their content constitutes requirements of this document. For dated references, only the edition cited applies. For undated references, the latest edition of the referenced document (including any amendments) applies.

ISO 128-2:—,¹⁾ *Technical product documentation (TPD) — General principles of presentation — Part 2: Basic conventions for lines* [catalog/standards/sist/75d888a5-6e9a-4fac-9120-8f2dffc20899/iso-128-2:2022](https://www.iso.org/standards/catalog/standards/sist/75d888a5-6e9a-4fac-9120-8f2dffc20899/iso-128-2:2022)

ISO 129-1, *Technical product documentation (TPD) — Presentation of dimensions and tolerances — Part 1: General principles*

ISO 3098-1, *Technical product documentation — Lettering — Part 1: General requirements*

ISO 5456-2, *Technical drawings — Projection methods — Part 2: Orthographic representations*

ISO 6428, *Technical drawings — Requirements for microcopying*

ISO 10209:2022, *Technical product documentation — Vocabulary — Terms relating to technical drawings, product definition and related documentation*

ISO 15519-1, *Specification for diagrams for process industry — Part 1: General rules*

ISO 81714-1, *Design of graphical symbols for use in the technical documentation of products — Part 1: Basic rules*

3 Terms and definitions

For the purposes of this document, the terms and definitions given in ISO 10209:2022 and the following apply.

ISO and IEC maintain terminology databases for use in standardization at the following addresses:

— ISO Online browsing platform: available at <https://www.iso.org/obp>

1) Under preparation. Stage at the time of publication: ISO/FDIS 128-2:2022.

— IEC Electropedia: available at <https://www.electropedia.org/>

3.1

cut

sectional view

section (3.2) showing, in addition, outlines beyond the cutting plane

Note 1 to entry: While “cut” is generally used in the construction field, “section” is generally used in the mechanical engineering field, regardless of the definitions in 3.1 or 3.2.

[SOURCE: ISO 10209:2022, 3.2.10, modified — Note 1 to entry added.]

3.2

section

representation showing only the outlines of an object lying in one or more cutting planes

Note 1 to entry: While “cut” is generally used in the construction field, “section” is generally used in the mechanical engineering field, regardless of the definitions in 3.1 or 3.2.

[SOURCE: ISO 10209:2022, 3.2.58, modified — Note 1 to entry revised.]

3.3

technical drawing

drawing showing a technical installation, process or product with a view to clarifying its structure and enabling its construction

Note 1 to entry: For the purpose of this document, the term “technical drawing” is interpreted in the broadest possible sense, encompassing the total package of documentation specifying the product (work piece, subassembly, assembly).

[SOURCE: ISO 5127:2017, 3.4.7.54, modified — Note 1 to entry replaced.]

4 Basic conventions for views

4.1 General information on views

The most informative view of an object shall be used as the principle view, taking into consideration, for example, its functioning position, position of manufacturing or mounting.

Each view, with the exception of the front or principal figure (view, plan, principal figure), shall be given clear identification with a capital letter, repeated near the reference arrow needed to indicate the direction of viewing for the relevant view. Whatever the direction of viewing, the capital letter shall always be positioned in normal relation to the direction of reading and be indicated either above or on the right side of the reference arrow.

The reference arrow is defined in [Annex A](#) (for the former practice of arc arrow, see [Annex B](#)), as is the lettering height of the identification.

The designated views may be located irrespective of the principal figure. The capital letters identifying the referenced views shall be placed immediately above the relevant views (see [Figure 1](#)).

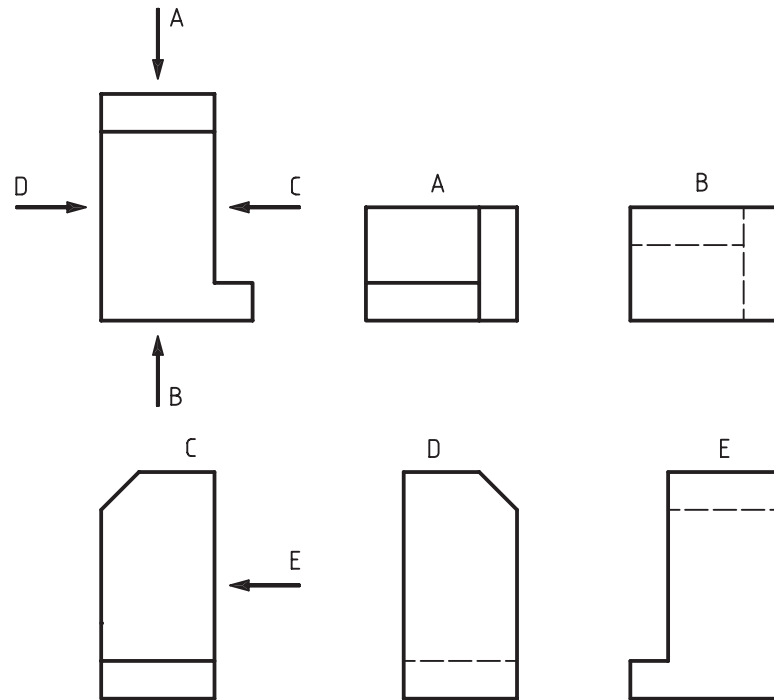

Figure 1 — Identification of referenced views

For applying views and sections to mechanical engineering technical drawings, [Annex C](#) and [Annex D](#) shall apply. For applying projection methods in building technical drawings, [Annex E](#) shall apply. For applying views, sections and cuts to construction technical drawings, [Annex F](#) shall apply.

4.2 Choice of views

When views (including cuts and sections) are needed, these shall be selected according to the following principles:

- limit the number of views (and cuts and sections) to the minimum necessary but sufficient to fully delineate the object without ambiguity;
- avoid the need for hidden outlines and edges;
- avoid unnecessary repetition of a detail.

Views and sections for 3D models are given in ISO 16792.

4.3 Partial views

Features needing specific illustration, but not meriting a full view, can be illustrated using a partial view limited by a continuous narrow line with zigzags of type 01.1 according to ISO 128-2:— (see [Figure 2](#)).

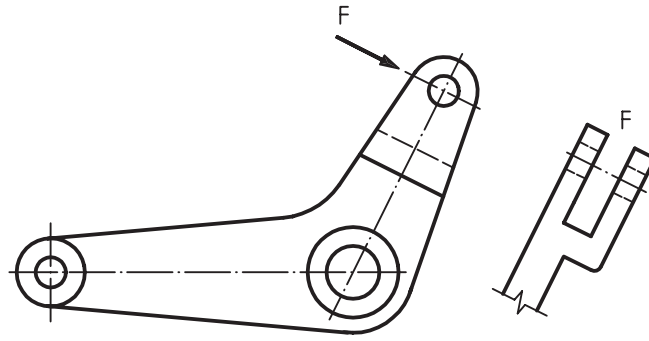

Figure 2 — Partial view

4.4 Simplified view of symmetrical parts

To save time and space, symmetrical objects can be drawn as a fraction of the whole [see Figure 3 a), b) and c)].

The line of symmetry is identified at each of its ends by two narrow short parallel lines drawn at right angles to it [see Figure 3 a), b) and c)]. The graphical symbol for symmetry shall be drawn in accordance with A.3.

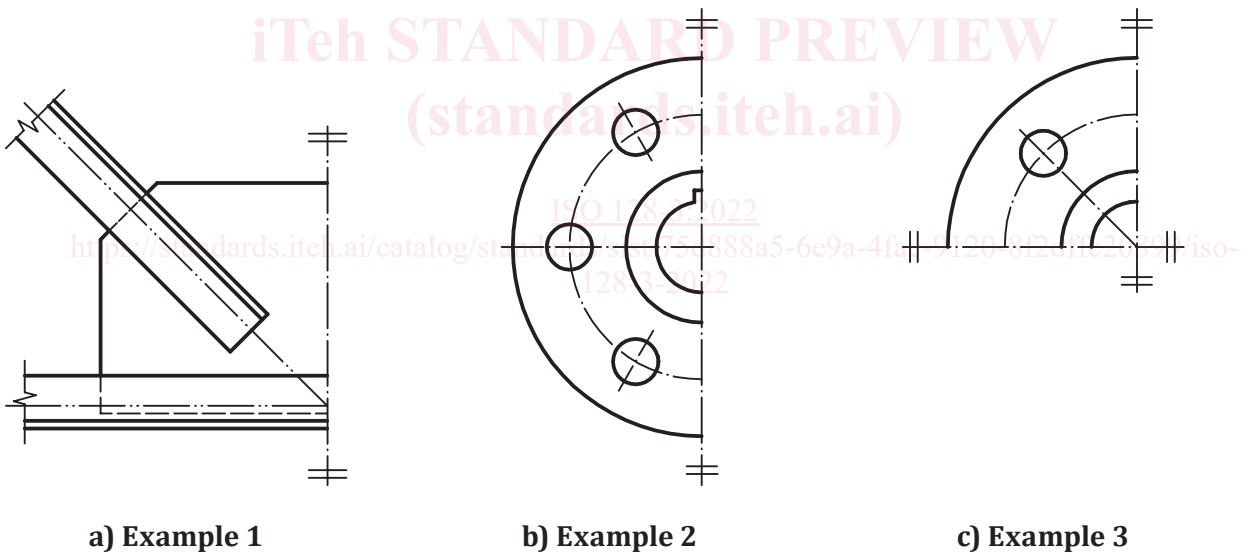

Figure 3 — Examples of simplified views of symmetrical parts

4.5 First-angle projection method

The first-angle projection method, if used, shall be in accordance with ISO 5456-2.

4.6 First-angle projection method views

With reference to the front view, (a), the other views are arranged as follows (see Figure 4):

- the view from above, (b), is placed underneath;
- the view from below, (e), is placed above;
- the view from the left, (c), is placed on the right;

- the view from the right, (d), is placed on the left;
- the view from the rear, (f), may be placed on the left or right, as convenient.

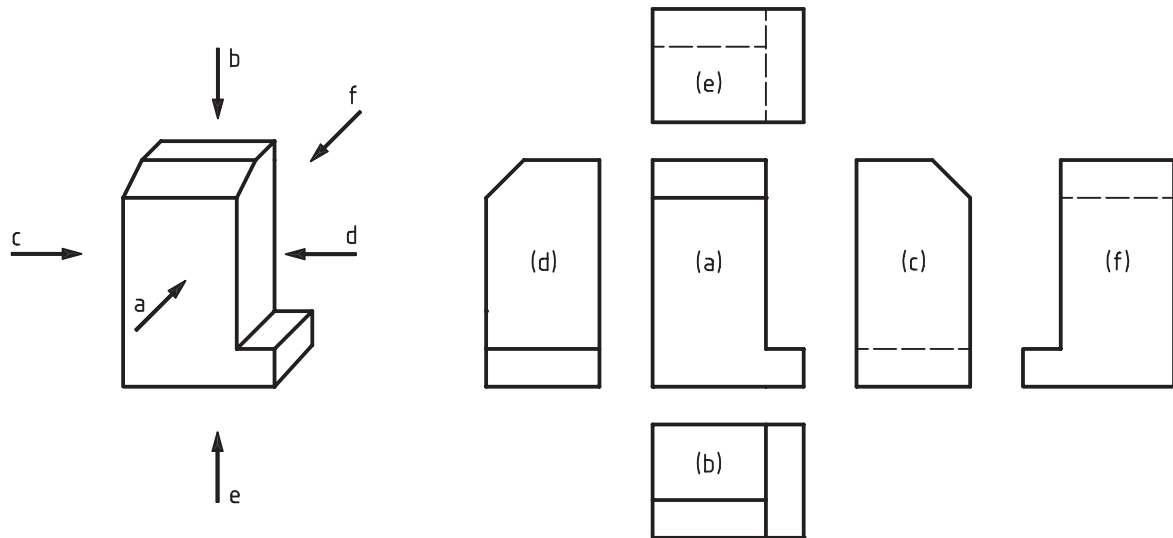

Figure 4 — First-angle projection method

4.7 First-angle projection graphical symbol

The graphical symbol for the first angle projection method is shown in Figure 5. The proportions and dimensions of this graphical symbol are specified in ISO 5456-2.

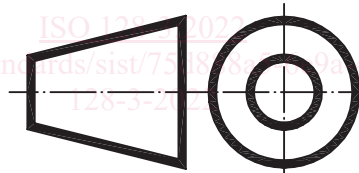

Figure 5 — First angle projection graphical symbol

4.8 Third-angle projection method

The third-angle projection method, if used, shall be in accordance with ISO 5456-2.

4.9 Third-angle projection method views

With reference to the front view, (a), the other views are arranged as follows (see Figure 6):

- the view from above, (b), is placed above;
- the view from below, (e), is placed underneath;
- the view from the left, (c), is placed on the left;
- the view from the right, (d), is placed on the right;
- the view from the rear, (f), may be placed on the left or right, as convenient.

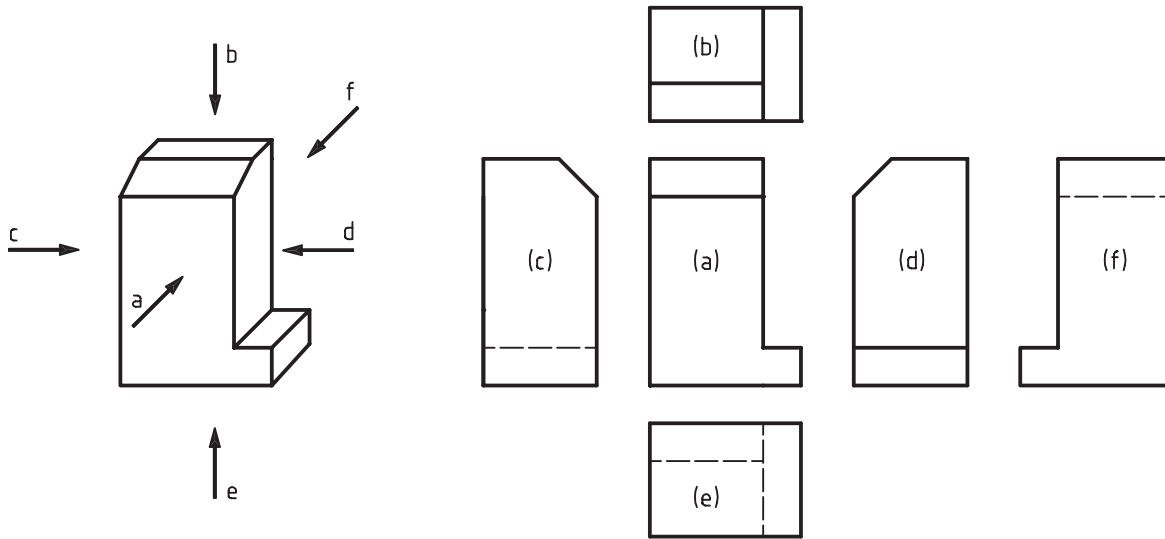

Figure 6 — Third-angle projection method

4.10 Third-angle projection graphical symbol

The graphical symbol for the third-angle projection method is shown in [Figure 7](#). The proportions and dimensions of this graphical symbol are specified in ISO 5456-2.

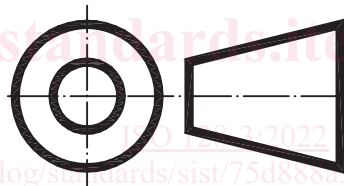

Figure 7 — Third-angle projection graphical symbol

4.11 Other projection methods

Refer to ISO 5456-2 for information on other projection methods, such as mirrored orthographic projections.

4.12 Enlarged features

When the scale of a technical drawing does not allow all features to be clearly shown or dimensioned, the unclear features shall be enclosed or encircled by a continuous narrow line (type 01.1), with the area thus enclosed identified by a capital letter. The features in the area shall also be shown on an enlarged scale, in a view that is broken with a continuous narrow freehand or free-formed curve line (type 01.1). This shall be accompanied by the identification letter and an indication of the scale beside it between parentheses, as shown in [Figure 8](#). The rules for lettering height are discussed in [Annex A](#).

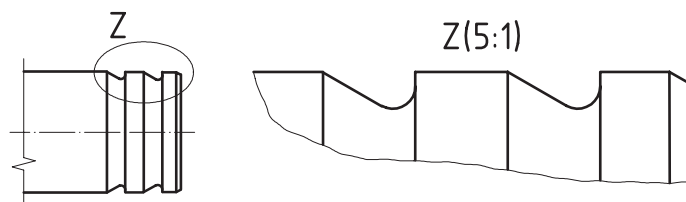

Figure 8 — Enlarged features

For unambiguous relation between the circle and the identification letter, a leader line by a continuous narrow line (type 01.1) and a reference line by a continuous narrow line (type 01.1) should be drawn. See [Figure 9](#).

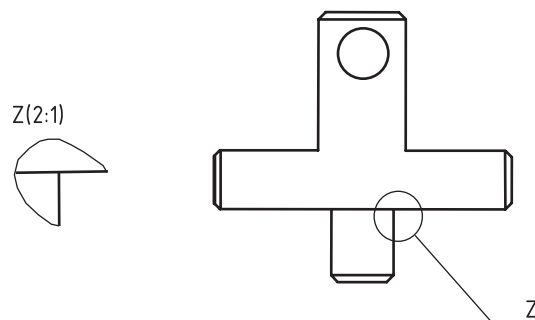

Figure 9 — Enlarged features with leader line

5 Reference indication for views and enlarged features

5.1 General

On large-format mechanical technical drawings and technical drawings consisting of more than one drawing sheet with an extensive amount of views and enlarged features, the readability should be improved by information (reference indication) after the identification letter of the views.

The purpose is to find the views and the identification letters more easily on the technical drawing or drawings.

On construction drawings, designations for views and enlarged features can be complemented by general reference to other drawings containing the views or features.

5.2 Details of the reference indication

The reference indication after the identification letter on the views shall be in accordance with ISO 15519-1.

Examples with explanation are shown in [Figure 10](#) and [Figure 11](#).

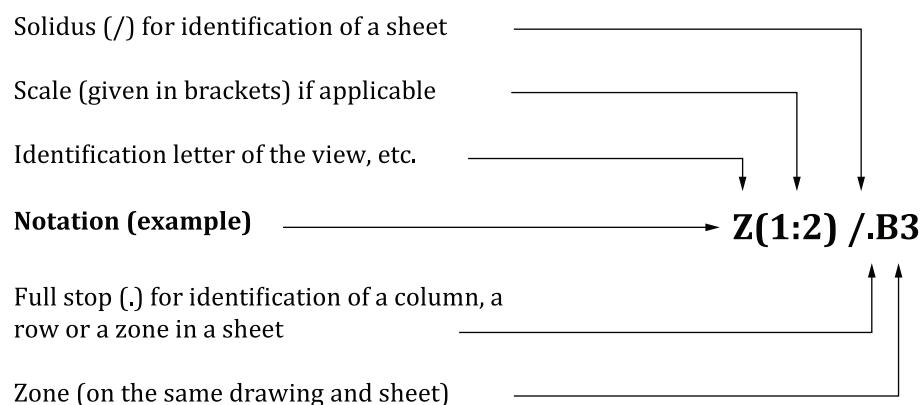

Figure 10 — Details of the reference indication with a single drawing

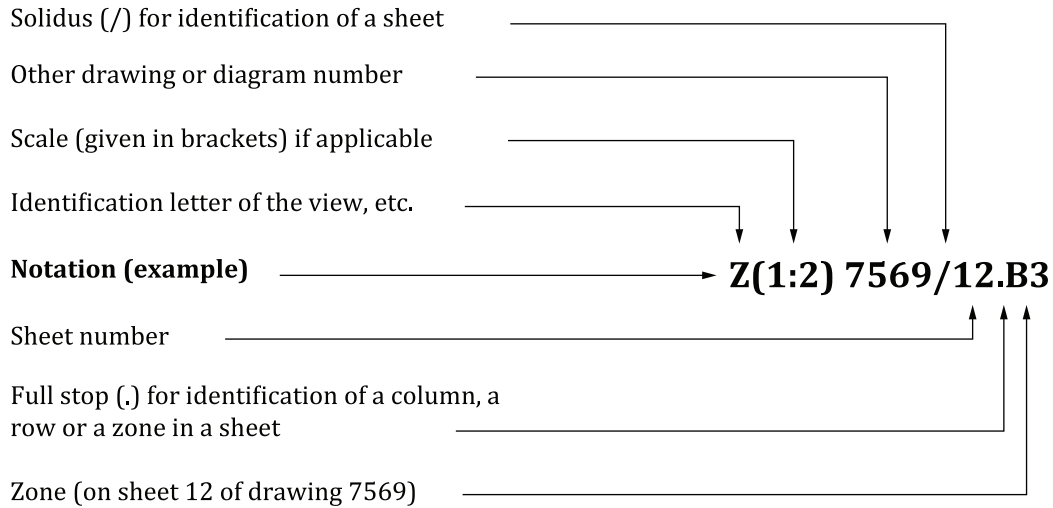

Figure 11 — Details of the reference indication with multiple drawings

5.3 Examples of indication

Examples of indication are given in Table 1.

Table 1 — Examples of indication

| Indication on technical drawing | Interpretation |
|---|--|
| <p>A /.C10</p> <p>B →</p> <p>← C</p> <p>D ↑</p> <p>A /.A3</p> | <p>View A is represented at technical drawing coordinates C10 on the same sheet.</p> <p>The identification letter and reference arrow on the main view is represented at technical drawing coordinates A3 on the same sheet.</p> |
| <p>Z /2.D5</p> | <p>Enlarged feature Z is represented at technical drawing coordinates D5 on sheet 2.</p> |
| <p>Z(5:1) /1.B3</p> | <p>The indication of the enlarged feature Z is represented at technical drawing coordinates B3 on sheet 1.</p> |

6 General information on cuts and sections

6.1 General

The general rules for the arrangement of views apply equally when drawing cuts and sections.

6.2 Indication of cuts and sections

6.2.1 Cutting plane

The position of the cutting plane(s) shall be indicated by means of a cutting line represented with a dashed dotted wide line (type 10.2) according to ISO 128-2:—, Annex E and Annex G. A straight cutting plane shall be drawn (see [Figure 12](#)).

If the cutting plane changes its direction, the cutting line should only be drawn at the ends of the cutting plane, where the cutting plane changes direction (see [Figure 13](#)).

If necessary for its legibility, the cutting line may be connected with a long-dashed dotted narrow line of the type 04.1 according to ISO 128-2:—, Annex D or 04.1 according to ISO 128-2:—, Annex F.

The direction of viewing for the relevant cut and section is indicated by the reference arrows as defined in [Annex A](#).

The designated cut and section can be located irrespective of the view in which the cutting plane is taken.

Representation of areas on cuts and sections is covered in [Clause 7](#).

6.2.2 Identification of the cutting plane

Each cut and section plane shall be given clear identification with twice the same capital letter, once at each of the cut and section arrows. This identification should be positioned for reading from the bottom of the technical drawing.

The 30° or 90° cut and section arrow is defined in [A.4](#), as is the lettering height of the identification.

6.2.3 Identification of the cuts and sections

The identification of the referenced cuts and sections shall be placed immediately above the relevant representation. (see [Figure 12](#) and [13](#)).

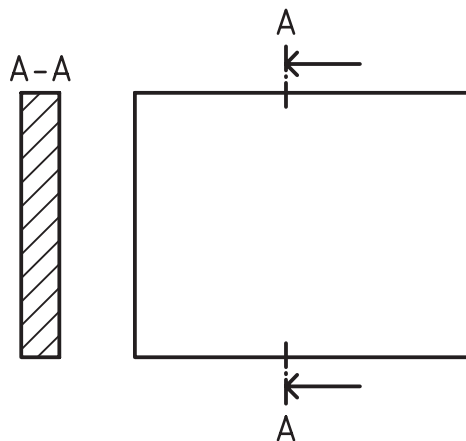

Figure 12 — Example from construction field