



Designation: B985 – 12

Standard Practice for Sampling Aluminum Ingots, Billets, Castings and Finished or Semi-Finished Wrought Aluminum Products for Compositional Analysis¹

This standard is issued under the fixed designation B985; the number immediately following the designation indicates the year of original adoption or, in the case of revision, the year of last revision. A number in parentheses indicates the year of last reapproval. A superscript epsilon (ϵ) indicates an editorial change since the last revision or reapproval.

1. Scope

1.1 This practice describes procedures for sampling unwrought aluminum ingots, billets, castings and finished or semi-finished wrought aluminum products to obtain a representative sample for determining chemical composition.

1.1.1 Chemical compositions determined from samples obtained in accordance with this standard practice may differ from the bulk chemical composition determined from samples taken when ingots or castings are poured. These differences can be due to elemental segregation that occurs during solidification, procedures that remove enriched material (e.g. ingot scalping), or procedures that remove depleted areas (e.g. removal of the riser from a casting).

1.1.2 Analysis of samples obtained from unwrought aluminum ingots, billets, and castings and finished or semi-finished wrought aluminum products can be used to determine if the piece sampled meets The Aluminum Association, Inc. registered chemical composition limits or other specified chemical composition limits for the alloy. Analysis of such samples shall not supersede the analysis of samples taken during pouring of castings or ingots in accordance with E716 and analyzed in accordance with E607, E1251, E34, or EN 14242 and shall not be used for determining compliance with chemical composition requirements for an entire cast lot or part thereof.

NOTE 1—Pieces may include ingots, forgings, coils, sheets, extrusions, castings, etc. A single unwrought ingot or billet may produce multiple finished or semi-finished pieces.

NOTE 2—Certification of entire cast lots should be determined using samples taken during pouring of castings or ingots in accordance with E716 and analyzed in accordance with E607, E1251, E34, or EN 14242.

1.2 *Units*—The values stated in either SI units or inch-pound units are to be regarded separately as standard. The values stated in each system may not be exact equivalents; therefore, each system shall be used independently of the other. Combining values from the two systems may result in non-conformance with the standard.

¹ This practice is under the jurisdiction of ASTM Committee B07 on Light Metals and Alloys and is the direct responsibility of Subcommittee B07.05 on Testing.

Current edition approved Dec. 1, 2012. Published January 2013. DOI: 10.1520/B0985-12.

1.3 *This standard does not purport to address all of the safety concerns, if any, associated with its use. It is the responsibility of the user of this standard to establish appropriate safety and health practices and determine the applicability of regulatory limitations prior to use.*

2. Referenced Documents

2.1 ASTM Standards:²

B881 Terminology Relating to Aluminum- and Magnesium-Alloy Products

E34 Test Methods for Chemical Analysis of Aluminum and Aluminum-Base Alloys

E135 Terminology Relating to Analytical Chemistry for Metals, Ores, and Related Materials

E607 Test Method for Atomic Emission Spectrometric Analysis Aluminum Alloys by the Point to Plane Technique Nitrogen Atmosphere (Withdrawn 2011)³

E716 Practices for Sampling and Sample Preparation of Aluminum and Aluminum Alloys for Determination of Chemical Composition by Spectrochemical Analysis

E1251 Test Method for Analysis of Aluminum and Aluminum Alloys by Spark Atomic Emission Spectrometry

2.2 Other Standards:⁴

EN 14242 Aluminum and aluminum alloys—Chemical analysis—Inductively coupled plasma optical emission spectral analysis

3. Terminology

3.1 For definitions of terms used in this Standard, refer to Terminologies E135 and B881.

4. Summary of Practice

4.1 The procedures described in this practice involve the cutting and drilling of aluminum products to obtain samples for

² For referenced ASTM standards, visit the ASTM website, www.astm.org, or contact ASTM Customer Service at service@astm.org. For *Annual Book of ASTM Standards* volume information, refer to the standard's Document Summary page on the ASTM website.

³ The last approved version of this historical standard is referenced on www.astm.org.

⁴ Available from European Committee for Standardization, Central Secretariat (CEN), rue de Stassart 36, B1050 Brussels, Belgium. <http://www.cen.eu/esearch>.

subsequent chemical analysis in accordance with ASTM Standards **E607**, **E1251**, **E34**, or EN 14242.

5. Significance and Use

5.1 Products covered by this practice are unwrought aluminum ingots, billets, and castings and unclad wrought aluminum sheet, plate, rolled or cold finished extrusions, extruded profiles, wire, rod and bar. Machined wrought products (finished or semi-finished) are excluded (see **Note 3**). These practices, used in conjunction with the appropriate sample preparation techniques in **E716** and the Test Methods **E34**, **E607**, **E1251**, and EN 14242, are suitable to determine if the piece sampled meets the chemical composition limits registered with the Aluminum Association Inc.⁵ or other specified chemical composition limits for the alloy. Analysis of such samples shall not supersede the analysis of samples taken during pouring of castings or ingots in accordance with **E716** and analyzed in accordance with **E607**, **E1251**, **E34**, or EN 14242 and shall not be used for determining compliance with chemical composition requirements for an entire cast lot or part thereof.

NOTE 3—Sampling machined pieces of products pose a particular problem because the piece itself may not be a representative sample of the original cast chemical composition. Larger differences may be expected between an analysis obtained from samples taken in accordance with this practice and the original cast analysis of samples taken during pouring of castings or ingot.

NOTE 4—Portable Spark-AES and hand held XRF instruments should not be used to determine if the piece sampled meets chemical composition limits registered with Aluminum Association Inc or other specified chemical composition limits for the alloy.

5.2 Users should be aware that chemical compositions determined using samples taken from unwrought aluminum ingots, billets, and castings and finished or semi-finished products might differ from the bulk chemical composition determined using samples taken when ingots or castings are poured. This difference can be due to elemental segregation upon solidification, sampling a non-homogenous section of the ingot or billet, removal of enriched material, or depleted areas of solidified material by subsequent procedures such as ingot scalping, the removal of risers from castings, or machining.

NOTE 5—When aluminum solidifies, macro-segregation may cause the chemical composition to vary throughout the ingot or casting. Certain areas may have enhanced or depleted concentrations of some elements relative to the average bulk chemical composition. Remnants of the macro-segregation may be retained in finished and semi-finished products. The sampling procedures described in this practice are designed to provide a laboratory sample for analysis which represents the chemical composition of the piece by taking samples in a way that symmetrically includes the various enhanced and depleted zones e.g. sampling across the radius of a round ingot etc.

6. Sampling and Handling Requirements Specific to Each Analysis Method

6.1 *Sampling for the Analysis of Chips by ASTM **E34** or EN 14242:*

6.1.1 Chips that will be prepared as described in **E34** or EN 14242 can be obtained by drilling or cutting and drilling at the

locations specified in Section 7 for each type of product. The chips should be uniformly small in size and free from scale, dirt, oil, grease, etc.

6.1.1.1 *Cleaning*—Oil and grease may be removed from the chips by rinsing with alcohol then drying before taking the laboratory sample. Scale and dirt may be removed by washing with a detergent and water then rinsing with distilled deionized water and drying before taking the laboratory sample. Additional chemical cleaning such as soaking the chips in 1% (by volume) nitric acid may be necessary to remove embedded contaminants. Other cleaning procedures may be used provided they do not alter the chemical composition in any way.

6.1.2 Use of a carbide or diamond tipped drill bit should provide satisfactory samples. To obtain chips, use a drill bit between 10 mm [0.4 in.] and 13 mm [0.5 in.] in diameter. A 25 mm [1 in.] deep hole with a 10 mm [0.4 in.] bit typically produces about 5 g [0.18 oz] of sample. Drill enough holes to collect at least 20 g [0.71 oz] of chips. The initial chips from an external surface shall be discarded for any surface that is contaminated i.e. lubricants, surface conditioning materials, dirt, scale, etc. The chips from all locations shall be thoroughly mixed prior to taking the laboratory sample for analysis.

NOTE 6—Using a drill bit made from bare HSS (high speed steel) may contaminate the sample with iron.

6.1.2.1 Other machining methods may be used provided that contamination-free chips are obtained from the specified area of the product being sampled. Products that are too thin to drill may be sampled by clipping off small samples.

6.2 *Sampling for Remelt Analysis using ASTM **E716** in Combination with ASTM **E1251**:*

6.2.1 Samples that will be re-melted (see **Notes 8 and 9**) in accordance with **E716** for subsequent elemental analysis using **E1251** should be obtained by cutting, (i.e. sawing, snipping, or shearing) at the locations specified in Section 7 for each type of product.

6.2.1.1 If it is not possible to obtain laboratory samples by cutting, laboratory samples may be obtained by drilling and re-melting the chips. Due to the high surface area of chips, it may be necessary to press the chips into solid pellets with sufficient pressure to compact the chips to reduce dross formation. Pressure of 140 MPa [20,000 psi] has been shown to be adequate for compressing chips.

6.2.2 The amount of laboratory sample required depends on the sampler type in use and the method used to preheat the sampler as required by **E716**. Preheating the sampler by taking and discarding a laboratory sample requires enough material for two laboratory samples. Preheating by other means requires enough material for one laboratory sample. The type B book molds and Alcoa vacuum samplers require approximately 150 g [6 oz] and 60 g [2.5 oz] of metal per laboratory sample respectively to completely fill the mold and sprue.

NOTE 7—A 25 mm [1 in.] cube of aluminum weighs approximately 45 g [1.5 oz].

6.2.3 If possible, combine all cut samples into a single laboratory sample in the remelt furnace. If the cut samples are too big for the remelt crucible, they may be cut into smaller size samples or multiple laboratory samples may be analyzed

⁵ Available from The Aluminum Association, Inc., 1525 Wilson Blvd., Suite 600, Arlington Va. 22209, <http://www.aluminum.org>.

separately. When analyzed separately, the chemical composition reported should be the average analysis determined from multiple remelt and cast laboratory samples for each element analyzed.

NOTE 8—Remelting is not satisfactory for the determination of calcium, lithium, sodium, and strontium. These elements may be lost due to oxidation and/or volatilization. Calcium, lithium, sodium, and strontium should be analyzed according to E34 or EN 14242 or by direct analysis on the surface of the original piece according to E1251 or E607, and results reported as approximate.

NOTE 9—Because magnesium and zinc may be lost if the melt is overheated or kept molten for an excessive time, the sample should be cast as soon as possible after it reaches a temperature of 700°C.

6.2.4 Using a saw equipped with a carbide or diamond tipped blade should provide satisfactory samples.

NOTE 10—The use of bare steel saw blades may contaminate the sample with iron.

6.2.4.1 *Cleaning*—Oil and grease may be removed from the samples by rinsing with alcohol then drying before taking the laboratory sample. Scale and dirt may be removed by washing with soap and water then rinsing with distilled de-ionized water and drying before taking the laboratory sample. Additional chemical cleaning such as soaking the samples in 1% (by volume) nitric acid may be necessary to remove embedded contaminants. Other cleaning methods may be used provided they do not alter the chemical composition in any way. (**Warning**—Chips and other cut samples must be dry before melting. Moisture captured in the material may cause it to eject heated metal or molten material and cause injury!)

7. Procedure for Obtaining Samples by Product Type

7.1 Ingots and Billets, Round:

7.1.1 *Sampling a Round Ingot by Drilling*—Prior to drilling, metal must be removed or cropped from the head and butt of round ingots. For ingots 250 mm [10 in.] or less in diameter, remove or crop at least 1.5 times the diameter from the head and butt of the ingot. For ingots greater than 250 mm [10 in.]

in diameter, remove or crop at least 380 mm [15 in.] from the head and butt of the ingot.

7.1.1.1 Drill holes in both the front and rear of the ingot as described below and shown in Fig. 1.

7.1.1.2 Drill two holes near the outer edge approximately 5 mm [0.2 in.] away from the as-cast surface.

7.1.1.3 Drill one hole near the center.

7.1.1.4 Drill three holes in the region approximately mid-way between the holes at the outer edge and the center.

7.1.1.5 Drill holes at least 25 mm [1 in.] into the face. Drillings from the front and rear of the ingot shall be treated as separate laboratory samples and analyzed separately. The results may be reported as individual samples or as the average. Both samples however, must be within the specification chemical composition limits. The piece sampled does not meet the specification chemical composition limits if one of the samples is outside of the chemical composition limits; even if the average is within the specification.

7.1.1.6 If more drilling locations are required to make up the required sample weight, repeat the above pattern. Drillings from additional locations are to be combined with the other drillings from the head or butt locations shown in Fig. 1.

7.1.2 *Sampling a Billet by Drilling*—Drill holes in both the front and rear of the billet as described below and shown in Fig. 1.

7.1.2.1 Drill two holes near the outer edge approximately 5 mm [0.2 in.] away from the as-cast surface.

7.1.2.2 Drill one hole near the center.

7.1.2.3 Drill three holes in the region approximately mid-way between the holes at the outer edge and the center.

7.1.2.4 Drill holes at least 25 mm [1 in.] into the face. Drillings from the front and rear shall be treated as separate laboratory samples and analyzed separately. The results may be reported as individual samples or as the average. Both samples however, must be within the specification chemical composition limits. The piece sampled does not meet the specification

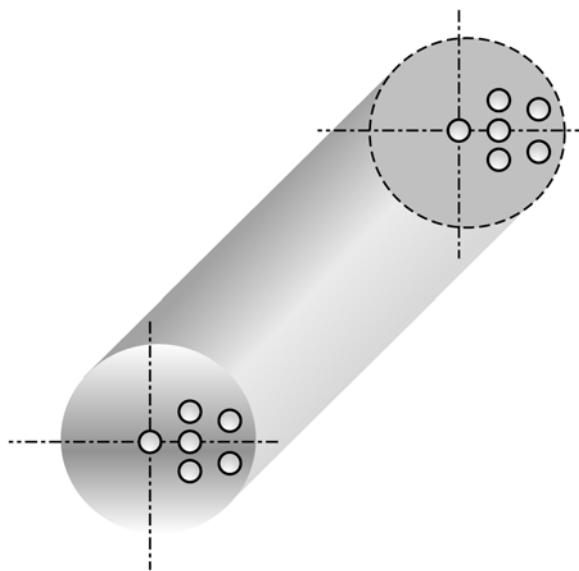

FIG. 1 Sampling a Round Ingot or Billet by Drilling

if one of the samples is outside of the chemical composition limits; even if the average is within the specification.

7.1.2.5 If more drilling locations are required to make up the required sample weight, repeat the above pattern. Drillings from additional locations are to be combined with the other drillings from the front or rear locations shown in Fig. 1.

7.1.3 *Sampling a Round Ingot by Cutting a Transverse Cross-sectional Slice and Drilling*—For ingots 250 mm [10 in.] or less in diameter, cut a transverse cross-sectional slice that is at least 25 mm [1 in.] thick from a location at least 1.5 times the ingot diameter from the head and butt of the ingot. For ingots greater than 250 mm [10 in.] in diameter, cut a transverse cross-sectional slice that is at least 25 mm [1 in.] thick from a location at least 380 mm [15 in.] from the head and butt of the ingot.

7.1.3.1 Drill holes through the full thickness of the cross-sectional slice as described below and shown in Fig. 1.

7.1.3.2 Drill two holes near the outer edge approximately 5 mm [0.2 in.] away from the as-cast surface.

7.1.3.3 Drill one hole near the center.

7.1.3.4 Drill three holes in the region approximately midway between the holes at the outer edge and the center.

7.1.3.5 Drillings from the head and butt slices shall be treated as separate laboratory samples and analyzed separately. The results may be reported as individual samples or as the average. Both samples however, must be within the specification chemical composition limits. The piece sampled does not meet the specification if one of the samples is outside of the chemical composition limits; even if the average is within the specification.

7.1.3.6 If more drilling locations are required to make up the required sample weight, repeat the above pattern. Drillings from additional locations are to be combined with the other drillings from the head or butt locations shown in Fig. 1.

7.1.3.7 Alternatively, chips may be collected from milling the complete face or symmetrical section (half, quarter, etc.) of the slice.

7.1.4 *Sampling a Billet by Cutting a Transverse Cross-sectional Slice and Drilling*—Cut a transverse cross-sectional slice that is at least 25 mm [1 in.] thick from the front and rear of the billet.

7.1.4.1 Drill holes through the full thickness of the cross-sectional slice as described below and shown in Fig. 1.

7.1.4.2 Drill two holes near the outer edge approximately 5 mm [0.2 in.] away from the as-cast surface.

7.1.4.3 Drill one hole near the center.

7.1.4.4 Drill three holes in the region approximately midway between the holes at the outer edge and the center.

7.1.4.5 Drillings from the front and rear slices shall be treated as separate laboratory samples and analyzed separately. The results may be reported as individual samples or as the average. Both samples however, must be within the specification chemical composition limits. The piece sampled does not meet the specification if one of the samples is outside of the chemical composition limits; even if the average is within the specification.

7.1.4.6 If more drilling locations are required to make up the required sample weight, repeat the above pattern. Drillings

from additional locations are to be combined with the other drillings from the front or rear locations shown in Fig. 1.

7.1.4.7 Alternatively, chips may be collected from milling the complete face or symmetrical section (half, quarter, etc.) of the slice.

7.1.5 *Sampling a Round Ingot by Cutting Samples from a Transverse Cross-sectional Slice*—For ingots 250 mm [10 in.] or less in diameter, cut a transverse cross-sectional slice that is at least 25 mm [1 in.] thick from a location at least 1.5 times the ingot diameter from the head and butt of the ingot. For ingots greater than 250 mm [10 in.] in diameter, cut a transverse cross-sectional slice that is at least 25 mm [1 in.] thick from a location at least 380 mm [15 in.] from the head and butt of the ingot. If the remelt furnace is large enough, it is preferable to melt the entire slice. If the remelt furnace is not large enough, samples should be cut from the slices as described below and shown in Fig. 1.

7.1.5.1 Cut two samples near the outer edge approximately 5 mm [0.2 in.] away from the as-cast surface.

7.1.5.2 Cut one sample near the center.

7.1.5.3 Cut three samples in the region approximately midway between the samples at the outer edge and the center.

7.1.5.4 Samples cut from the head and butt shall be treated as separate laboratory samples and analyzed separately. The results may be reported as individual samples or as the average. Both samples however, must be within the specification chemical composition limits. The piece sampled does not meet the specification if one of the samples is outside of the chemical composition limits; even if the average is within the specification.

7.1.5.5 If more samples are required to make up the required sample weight, repeat the above pattern. Samples cut from additional locations are to be combined with other samples cut from the head or butt locations shown in Fig. 1.

7.1.6 *Sampling a Billet by Cutting Samples from a Transverse Cross-sectional Slice*—Cut a transverse cross-sectional slice that is at least 25 mm [1 in.] thick from the front and rear of the billet. Samples should be cut from the slices as described below and shown in Fig. 1.

7.1.6.1 Cut two samples near the outer edge approximately 5 mm [0.2 in.] away from the as-cast surface.

7.1.6.2 Cut one sample near the center.

7.1.6.3 Cut three samples in the region approximately midway between the samples at the outer edge and the center.

7.1.6.4 Samples cut from the front and rear shall be treated as separate laboratory samples and analyzed separately. The results may be reported as individual samples or as the average. Both samples however, must be within the specification chemical composition limits. The piece sampled does not meet the specification if one of the samples is outside of the chemical composition limits; even if the average is within the specification.

7.1.6.5 If more samples are required to make up the required sample weight, repeat the above pattern. Samples cut from additional locations are to be combined with the other samples cut from the front or rear locations shown in Fig. 1.

7.2 *Ingot, Rectangular:*