



Designation: E399 – 12

# Standard Test Method for Linear-Elastic Plane-Strain Fracture Toughness $K_{Ic}$ of Metallic Materials<sup>1</sup>

This standard is issued under the fixed designation E399; the number immediately following the designation indicates the year of original adoption or, in the case of revision, the year of last revision. A number in parentheses indicates the year of last reappraisal. A superscript epsilon ( $\epsilon$ ) indicates an editorial change since the last revision or reappraisal.

*This standard has been approved for use by agencies of the Department of Defense.*

## 1. Scope

1.1 This test method covers the determination of fracture toughness ( $K_{Ic}$ ) of metallic materials under predominantly linear-elastic, plane-strain conditions using fatigue precracked specimens having a thickness of 1.6 mm (0.063 in.) or greater<sup>2</sup> subjected to slowly, or in special (elective) cases rapidly, increasing crack-displacement force. Details of test apparatus, specimen configuration, and experimental procedure are given in the Annexes.

NOTE 1—Plane-strain fracture toughness tests of thinner materials that are sufficiently brittle (see 7.1) can be made using other types of specimens (1).<sup>3</sup> There is no standard test method for such thin materials.

1.2 This test method is divided into two parts. The first part gives general recommendations and requirements for  $K_{Ic}$  testing. The second part consists of Annexes that give specific information on displacement gage and loading fixture design, special requirements for individual specimen configurations, and detailed procedures for fatigue precracking. Additional annexes are provided that give specific procedures for beryllium and rapid-force testing.

1.3 General information and requirements common to all specimen configurations:

Referenced Documents	Section
Terminology	2
Stress-Intensity Factor	3.1.1
Plane-Strain Fracture Toughness	3.1.2
Crack Plane Orientation	3.1.3

Summary of Test Method	Section
Significance and Use	4
Significance	5
Precautions	5.1
Practical Applications	5.1.1-5.1.5
Apparatus (see also 1.4)	5.2
Tension Machine	6
Fatigue Machine	6.1
Loading Fixtures	6.2
Displacement Gage, Measurement	6.3
Specimen Size, Configurations, and Preparation (see also 1.5)	6.4
Specimen Size Estimates	7
Standard and Alternative Specimen Configurations	7.1
Fatigue Crack Starter Notches	7.2
Fatigue Precracking (see also 1.6)	7.3.1
Crack Extension Beyond Starter Notch	7.3.2
General Procedure	7.3.2.2
Specimen Measurements	8
Thickness	8.2.1
Width	8.2.2
Crack Size	8.2.3
Crack Plane Angle	8.2.4
Specimen Testing	
Loading Rate	8.3
Test Record	8.4
Calculation and Interpretation of Results	9
Test Record Analysis	9.1
$P_{max}/P_C$ Validity Requirement	9.1.3
Specimen Size Validity Requirements	9.1.4
Reporting	10
Precision and Bias	11

## 1.4 Specific requirements related to test apparatus:

Double-Cantilever Displacement Gage	Annex A1
Testing Fixtures	Annex A2
Bend Specimen Loading Fixture	Annex A2.1
Compact Specimen Loading Clevis	Annex A2.2

## 1.5 Specific requirements related to individual specimen configurations:

Bend Specimen $SE(B)$	Annex A3
Compact Specimen $C(T)$	Annex A4
Disk-Shaped Compact Specimen $DC(T)$	Annex A5
Arc-Shaped Tension Specimen $A(T)$	Annex A6
Arc-Shaped Bend Specimen $A(B)$	Annex A7

<sup>1</sup> This test method is under the jurisdiction of ASTM Committee E08 on Fatigue and Fracture and is the direct responsibility of Subcommittee E08.07 on Fracture Mechanics.

Current edition approved Nov. 15, 2012. Published January 2013. Originally approved in 1970. Last previous edition approved in 2009 as E399 – 09<sup>2</sup>. DOI: 10.1520/E0399-12.

<sup>2</sup> For additional information relating to the fracture toughness testing of aluminum alloys, see Practice B645.

<sup>3</sup> The boldface numbers in parentheses refer to the list of references at the end of this standard.

### 1.6 Specific requirements related to special test procedures:

Fatigue Precracking K<sub>Ic</sub> Specimens  
 Hot-Pressed Beryllium Testing  
 Rapid-Force Testing

Annex A8  
 Annex A9  
 Annex A10

1.7 The values stated in SI units are to be regarded as the standard. The values given in parentheses are for information only.

1.8 *This standard does not purport to address all of the safety concerns, if any, associated with its use. It is the responsibility of the user of this standard to establish appropriate safety and health practices and determine the applicability of regulatory limitations prior to use.*

## 2. Referenced Documents

### 2.1 ASTM Standards:<sup>4</sup>

**B909** Guide for Plane Strain Fracture Toughness Testing of Non-Stress Relieved Aluminum Products

**B645** Practice for Linear-Elastic Plane-Strain Fracture Toughness Testing of Aluminum Alloys

**E4** Practices for Force Verification of Testing Machines

**E8/E8M** Test Methods for Tension Testing of Metallic Materials

**E177** Practice for Use of the Terms Precision and Bias in ASTM Test Methods

**E337** Test Method for Measuring Humidity with a Psychrometer (the Measurement of Wet- and Dry-Bulb Temperatures)

**E456** Terminology Relating to Quality and Statistics

**E691** Practice for Conducting an Interlaboratory Study to Determine the Precision of a Test Method

**E1820** Test Method for Measurement of Fracture Toughness

**E1823** Terminology Relating to Fatigue and Fracture Testing

**E1921** Test Method for Determination of Reference Temperature,  $T_o$ , for Ferritic Steels in the Transition Range

<http://standards.iteh.ai/catalog/standards/sist/13835294->

## 3. Terminology

3.1 *Definitions:* Terminology **E1823** is applicable to this test method:

3.1.1 *stress-intensity factor, K, K<sub>I</sub>, K<sub>II</sub>, K<sub>III</sub> [FL<sup>-3/2</sup>]*—magnitude of the ideal-crack-tip stress field (a stress-field singularity), for a particular mode of crack displacement, in a homogeneous, linear-elastic body.

3.1.1.1 *K* is a function of applied force and test specimen size, geometry, and crack size, and has the dimensions of force times length<sup>-3/2</sup>.

3.1.1.2 Values of *K* for modes I, II, and III are given as:

$$K_I = \lim_{r \rightarrow 0} [\sigma_{yy}(2\pi r)^{1/2}] \quad (1)$$

$$K_{II} = \lim_{r \rightarrow 0} [\tau_{xy}(2\pi r)^{1/2}] \quad (2)$$

<sup>4</sup> For referenced ASTM standards, visit the ASTM website, [www.astm.org](http://www.astm.org), or contact ASTM Customer Service at [service@astm.org](mailto:service@astm.org). For *Annual Book of ASTM Standards* volume information, refer to the standard's Document Summary page on the ASTM website.

$$K_{III} = \lim_{r \rightarrow 0} [\tau_{yz}(2\pi r)^{1/2}] \quad (3)$$

where *r* is the distance directly forward from the crack tip to the location where the significant stress is calculated.

3.1.2 *plane-strain fracture toughness, K<sub>Ic</sub> [FL<sup>-3/2</sup>]*—the crack-extension resistance under conditions of crack-tip plane strain in Mode I for slow rates of loading under predominantly linear-elastic conditions and negligible plastic-zone adjustment. The stress intensity factor, *K<sub>Ic</sub>*, is measured using the operational procedure (and satisfying all of the validity requirements) specified in Test Method E399, that provides for the measurement of crack-extension resistance at the onset (2% or less) of crack extension and provides operational definitions of crack-tip sharpness, onset of crack extension, and crack-tip plane strain.

3.1.2.1 See also definitions of crack-extension resistance, crack-tip plane strain, and mode in Terminology **E1823**.

3.1.3 *crack plane orientation*—identification of the plane and direction of crack extension in relation to the characteristic directions of the product. A hyphenated code defined in Terminology **E1823** is used wherein the letter(s) preceding the hyphen represents the direction normal to the crack plane and the letter(s) following the hyphen represents the anticipated direction of crack extension (see Fig. 1).

3.1.3.1 *Wrought Products*—the fracture toughness of wrought material depends on, among other factors, the orientation and propagation direction of the crack in relation to the material's anisotropy, which depends, in turn, on the principal directions of mechanical working and grain flow. Orientation of the crack plane shall be identified wherever possible. In addition, product form shall be identified (for example, straight-rolled plate, cross-rolled plate, pancake forging, and so forth) along with material condition (for example, annealed, solution treated plus aged, and so forth). The user shall be referred to product specifications for detailed processing information.

3.1.3.2 For rectangular sections, the reference directions are identified as in Fig. 1(a) and Fig. 1(b), which give examples for rolled plate. The same system is used for sheet, extrusions, and forgings with nonsymmetrical grain flow.

L = direction of principal deformation (maximum grain flow)  
 T = direction of least deformation  
 S = third orthogonal direction

3.1.3.3 Using the two-letter code, the first letter designates the direction normal to the crack plane, and the second letter the expected direction of crack propagation. For example, in Fig. 1(a), the T-L specimen fracture plane normal is in the width direction of a plate and the expected direction of crack propagation is coincident with the direction of maximum grain flow (or longitudinal) direction of the plate.

3.1.3.4 For specimens tilted in respect to two of the reference axes as in Fig. 1(b), crack plane orientation is identified by a three-letter code. The designation L-TS, for example, indicates the crack plane to be perpendicular to the principal deformation (L) direction, and the expected fracture direction to be intermediate between T and S. The designation TS-L means that the crack plane is perpendicular to a direction

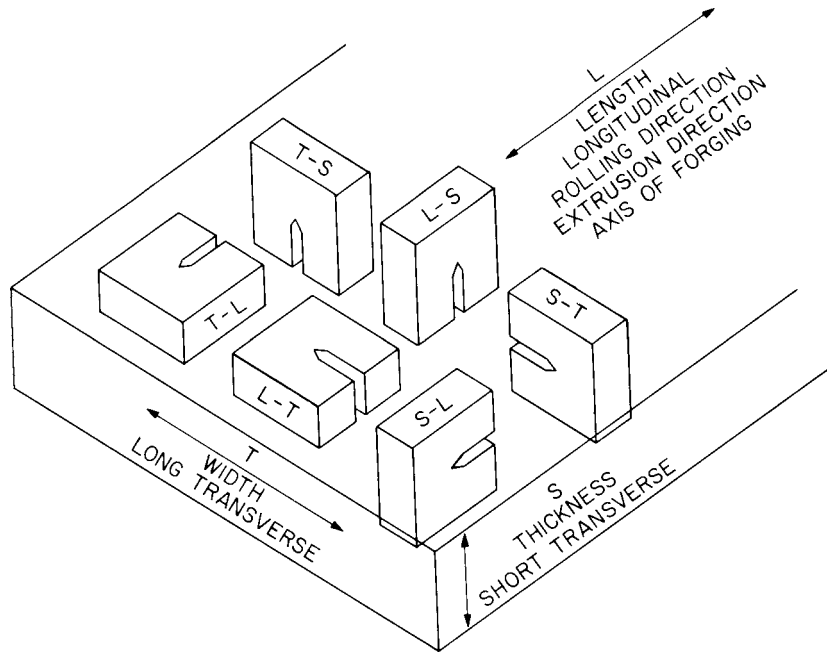

(a) Rectangular Sections—Specimens Aligned with Reference Directions

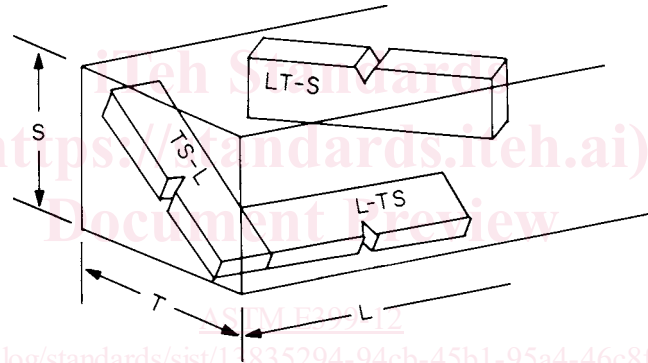

(b) Rectangular Sections—Specimens Not Aligned with Reference Directions

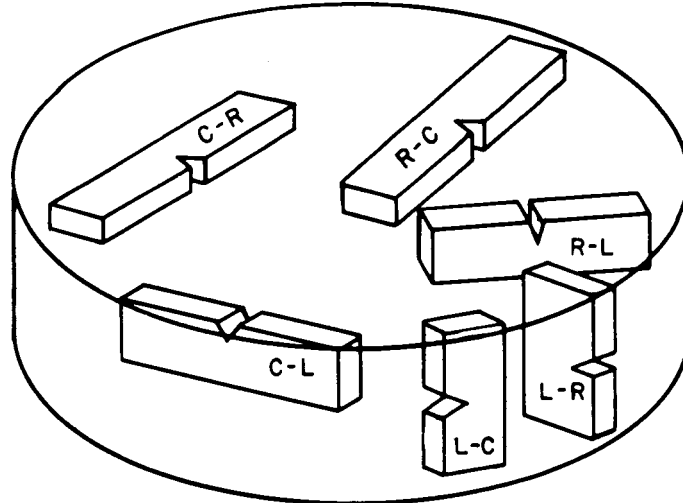

(c) Cylindrical Bars and Tubes

L = direction of maximum grain flow  
 R = radial direction  
 C = circumferential or tangential direction

FIG. 1 Crack Plane Identification

intermediate between T and S, and the expected fracture direction is in the L direction.

3.1.3.5 For cylindrical sections, where grain flow can be in the longitudinal, radial or circumferential direction, specimen location and crack plane orientation shall reference original cylindrical section geometry such that the L direction is always the axial direction for the L-R-C system, as indicated in Fig. 1(c), regardless of the maximum grain flow. Note that this is a geometry based system. As such, the direction of maximum grain flow shall be reported when the direction is known.

NOTE 2—The same system is useful for extruded or forged parts having circular cross section. In most cases the L direction corresponds to the direction of maximum grain flow, but some products such as pancake, disk, or ring forgings can have the R or C directions correspond to the direction of maximum grain flow, depending on the manufacturing method.

L = axial direction  
R = radial direction  
C = circumferential or tangential direction

3.1.3.6 In the case of complex structural shapes, where the grain flow is not uniform, specimen location and crack plane orientation shall reference host product form geometry and be noted on component drawings.

3.1.3.7 *Non-Wrought Products*—for non-wrought products, specimen location and crack plane orientation shall be defined on the part drawing. The result of a fracture toughness test from a non-wrought product shall not carry an orientation designation.

3.1.3.8 *Discussion*—when products are to be compared on the basis of fracture toughness, it is essential that specimen location and orientation with respect to product characteristic directions be comparable and that the results not be generalized beyond these limits.

### 3.2 Definitions of Terms Specific to This Standard:

3.2.1 *crack mouth opening displacement (CMOD)*,  $V_m$  [L]—component of clip gage displacement taken at the crack starter-notch mouth.

3.2.2 *stress-intensity factor rate*,  $\dot{K}$  ( $FL^{-3/2} t^{-1}$ )—change in stress-intensity factor,  $K$ , per unit time.

## 4. Summary of Test Method

4.1 This test method covers the determination of the plane-strain fracture toughness ( $K_{Ic}$ ) of metallic materials by increasing-force tests of fatigue precracked specimens. Force is applied either in tension or three-point bending. Details of the test specimens and experimental procedures are given in the Annexes. Force versus crack-mouth opening displacement (CMOD) is recorded either autographically or digitally. The force at a 5 % secant offset from the initial slope (corresponding to about 2.0 % apparent crack extension) is established by a specified deviation from the linear portion of the record (1). The value of  $K_{Ic}$  is calculated from this force using equations that have been established by elastic stress analysis of the specimen configurations specified in this test method. The validity of the  $K_{Ic}$  value determined by this test method depends upon the establishment of a sharp-crack condition at the tip of the fatigue crack in a specimen having a size adequate to ensure predominantly linear-elastic, plane-strain conditions. To establish the suitable crack-tip condition, the stress-

intensity factor level at which specimen fatigue precracking is conducted is limited to a relatively low value.

4.2 The specimen size required for test validity increases as the square of the material's toughness-to-yield strength ratio. Therefore a range of proportional specimens is provided.

## 5. Significance and Use

5.1 The property  $K_{Ic}$  determined by this test method characterizes the resistance of a material to fracture in a neutral environment in the presence of a sharp crack under essentially linear-elastic stress and severe tensile constraint, such that (1) the state of stress near the crack front approaches tritensile plane strain, and (2) the crack-tip plastic zone is small compared to the crack size, specimen thickness, and ligament ahead of the crack.

5.1.1 Variation in the value of  $K_{Ic}$  can be expected within the allowable range of specimen proportions,  $a/W$  and  $W/B$ .  $K_{Ic}$  may also be expected to rise with increasing ligament size. Notwithstanding these variations, however,  $K_{Ic}$  is believed to represent a lower limiting value of fracture toughness (for 2 % apparent crack extension) in the environment and at the speed and temperature of the test.

5.1.2 Lower values of  $K_{Ic}$  can be obtained for materials that fail by cleavage fracture; for example, ferritic steels in the ductile-to-brittle transition region or below, where the crack front length affects the measurement in a stochastic manner independent of crack front constraint. The present test method does not apply to such materials and the user is referred to Test Method E1921 and E1820. Likewise this test method does not apply to high toughness or high tearing-resistance materials whose failure is accompanied by appreciable amounts of plasticity. Guidance on testing elastic-plastic materials is given in Test Method E1820.

5.1.3 The value of  $K_{Ic}$  obtained by this test method may be used to estimate the relation between failure stress and crack size for a material in service wherein the conditions of high constraint described above would be expected. Background information concerning the basis for development of this test method in terms of linear elastic fracture mechanics may be found in Refs (1) and (3).

5.1.4 Cyclic forces can cause crack extension at  $K_I$  values less than  $K_{Ic}$ . Crack extension under cyclic or sustained forces (as by stress corrosion cracking or creep crack growth) can be influenced by temperature and environment. Therefore, when  $K_{Ic}$  is applied to the design of service components, differences between laboratory test and field conditions shall be considered.

5.1.5 Plane-strain fracture toughness testing is unusual in that there can be no advance assurance that a valid  $K_{Ic}$  will be determined in a particular test. Therefore, compliance with the specified validity criteria of this test method is essential.

5.1.6 Residual stresses can adversely affect the indicated  $K_Q$  and  $K_{Ic}$  values. The effect can be especially significant for specimens removed from as-heat treated or otherwise non-stress relieved stock, from weldments, from complex wrought parts, or from parts with intentionally induced residual stresses. Indications of residual stress include distortion during specimen machining, results that are specimen configuration

dependent, and irregular fatigue precrack growth (either excessive crack front curvature or out-of-plane growth). Guide B909 provides supplementary guidelines for plane strain fracture toughness testing of aluminum alloy products for which complete stress relief is not practicable. Guide B909 includes additional guidelines for recognizing when residual stresses may be significantly biasing test results, methods for minimizing the effects of residual stress during testing, and guidelines for correction and interpretation of data.

5.2 This test method can serve the following purposes:

5.2.1 In research and development, to establish in quantitative terms significant to service performance, the effects of metallurgical variables such as composition or heat treatment, or of fabricating operations such as welding or forming, on the fracture toughness of new or existing materials.

5.2.2 In service evaluation, to establish the suitability of a material for a specific application for which the stress conditions are prescribed and for which maximum flaw sizes can be established with confidence.

5.2.3 For specifications of acceptance and manufacturing quality control, but only when there is a sound basis for specifying minimum  $K_{Ic}$  values, and then only if the dimensions of the product are sufficient to provide specimens of the size required for valid  $K_{Ic}$  determination. The specification of  $K_{Ic}$  values in relation to a particular application should signify that a fracture control study has been conducted for the component in relation to the expected loading and environment, and in relation to the sensitivity and reliability of the crack detection procedures that are to be applied prior to service and subsequently during the anticipated life.

6. Apparatus

6.1 *Testing Machine and Force Measurement*—The calibration of the testing machine shall be verified in accordance with Practices E4. The test machine shall have provisions for autographic recording of the force applied to the specimen; or, alternatively, a computer data acquisition system that may be used to record force and CMOD for subsequent analysis.

6.2 *Fatigue Precracking Machine*—When possible, the calibration of the fatigue machine and force-indicating device shall be verified statically in accordance with Practices E4. If the machine cannot be calibrated and verified statically, the applied force shall otherwise be known to  $\pm 2.5\%$ . Careful alignment of the specimen and fixturing is necessary to encourage straight fatigue cracks. The fixturing shall be such that the stress distribution is uniform across the specimen thickness and symmetrical about the plane of the prospective crack.

6.3 *Loading Fixtures*—Fixtures suitable for loading the specified specimen configurations are shown in the Annexes. The fixtures are designed to minimize friction contributions to the measured force.

6.4 *Displacement Gage*—The displacement gage electrical output represents relative displacement (V) of two precisely located gage positions spanning the crack starter notch mouth. Exact and positive positioning of the gage on the specimen is essential, yet the gage must be released without damage when the specimen breaks. Displacement gage and knife-edge designs shall provide for free rotation of the points of contact between the gage and the specimen. A recommended design for a self-supporting, releasable displacement gage is shown in

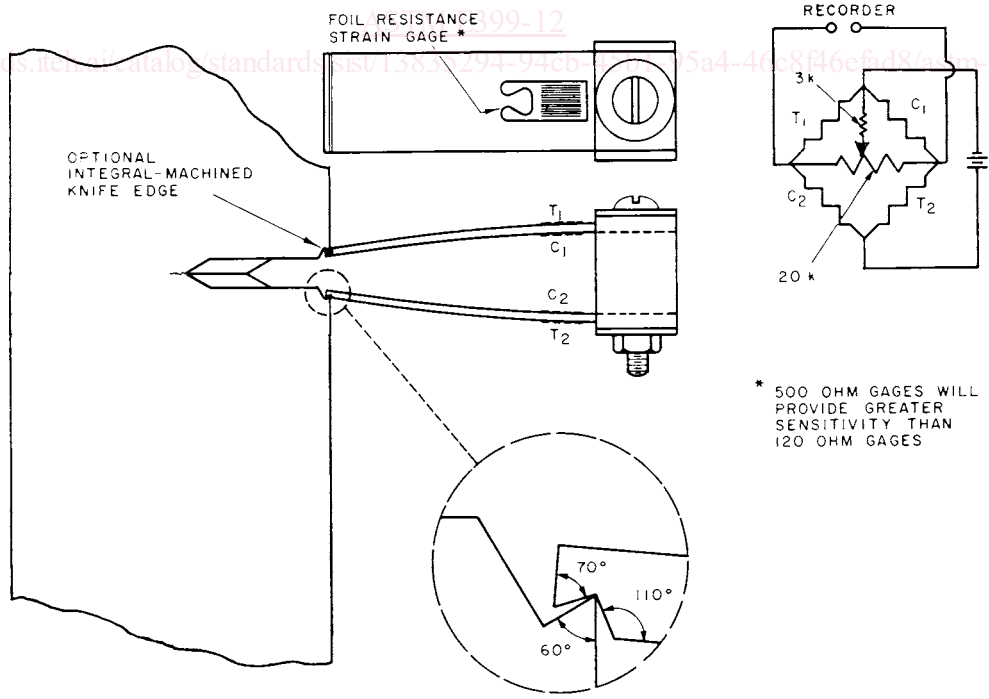

NOTE—Gage details are given in the Annex.

FIG. 2 Double-Cantilever Clip-In Displacement Gage Showing Mounting by Means of Integral Knife Edges (Gage Design Details are Given in Annex A1)

Fig. 2 and described in Annex A1. The gage's strain gage bridge arrangement is also shown in Fig. 2.

6.4.1 The specimen shall be provided with a pair of accurately machined knife edges to support the gage arms and serve as displacement reference points. The knife edges may be machined integral with the specimen as shown in Figs. 2 and 3, or they may be separate pieces affixed to the specimen. A suggested design for attachable knife edges is shown in Fig. 4. This design features a knife edge spacing of 5 mm (0.2 in.). The effective gage length is established by the points of contact between the screw and the hole threads. For the design shown, the major diameter of the screw is used in setting this gage length. A No. 2 screw will permit the use of attachable knife edges for specimens having  $W > 25$  mm (1.0 in.).

6.4.2 Each gage shall be verified for linearity using an extensometer calibrator or other suitable device. The resolution of the calibrator at each displacement interval shall be within 0.00051 mm (0.000020 in.). Readings shall be taken at ten equally spaced intervals over the working range of the gage (see Annex A1). The verification procedure shall be performed three times, removing and reinstalling the gage in the calibration fixture after each run. The required linearity shall correspond to a maximum deviation of 0.003 mm (0.0001 in.) of the individual displacement readings from a least-squares-best-fit straight line through the data. The absolute accuracy, as such, is not important in this application, since the test method is concerned with relative changes in displacement rather than absolute values (see 9.1). Verification of gage calibration shall be performed at the temperature of test  $\pm 5.6^\circ\text{C}$  ( $10^\circ\text{F}$ ). The gage shall be verified during the time the gage is in use at time intervals defined by established quality assurance practices. Commercial gages are typically verified annually.

6.4.3 It is not the intent of this test method to exclude the use of other types of gages or gage-fixing devices provided the

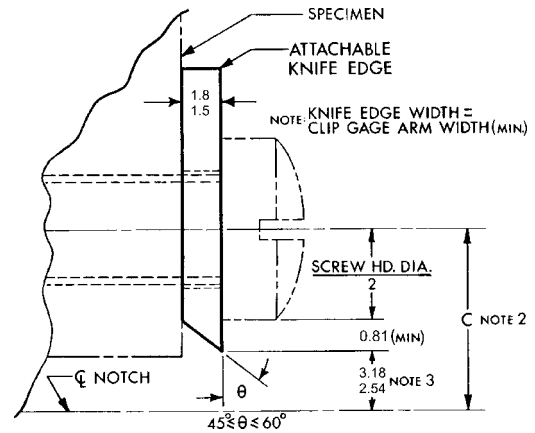

NOTE 1—Dimensions are in mm.

NOTE 2—Effective gage length =  $2C + \text{Screw Thread Diameter} \leq W/2$ . (This will always be greater than the gage length specified in A1.1.)

NOTE 3—Dimension shown corresponds to clip gage spacer block dimension in Annex A1.

Inch-Pound Units Equivalents					
mm	0.81	1.5	1.8	2.54	3.18
in.	0.032	0.060	0.070	0.100	0.125

FIG. 4 Example of Attachable Knife Edge Design

gage used meets the requirements listed above and provided the gage length does not exceed those limits given in the Annex appropriate to the specimen being tested.

## 7. Specimen Size, Configurations, and Preparation

### 7.1 Specimen Size:

7.1.1 In order for a result to be considered valid according to this test method (see also 3.1.2.1), the specimen ligament size ( $W - a$ ) must be not less than  $2.5(K_{Ic}/\sigma_{YS})^2$ , where  $\sigma_{YS}$  is the 0.2% offset yield strength of the material in the environment and orientation, and at the temperature and loading rate of the test (1, 4, 5). For testing at rates other than quasi-static see Annex A10, Rapid Force Testing. The specimen must also be of sufficient thickness,  $B$ , to satisfy the specimen proportions in 7.2.1 or 7.2.1.1 and meet the  $P_{max}/P_Q$  requirement in 9.1.3. Meeting the ligament size and  $P_{max}/P_Q$  requirements cannot be assured in advance. Thus, specimen dimensions shall be conservatively selected for the first test in a series. If the form of the material available is such that it is not possible to obtain a test specimen with ligament size equal to or greater than  $2.5(K_{Ic}/\sigma_{YS})^2$ , then it is not possible to make a valid  $K_{Ic}$  measurement according to this test method.

7.1.2 The initial selection of specimen size for a valid  $K_{Ic}$  measurement is often based on an estimated value of  $K_{Ic}$  for the material.

7.1.3 Alternatively, the ratio of yield strength to elastic modulus may be used for selecting a specimen size that will be adequate for all but the toughest materials:

$\sigma_{YS}/E$	Minimum Recommended Ligament Size	
	mm	in.
0.0050 to 0.0057	76	3
0.0057 to 0.0062	64	2½
0.0062 to 0.0065	51	2
0.0065 to 0.0068	44	1¾

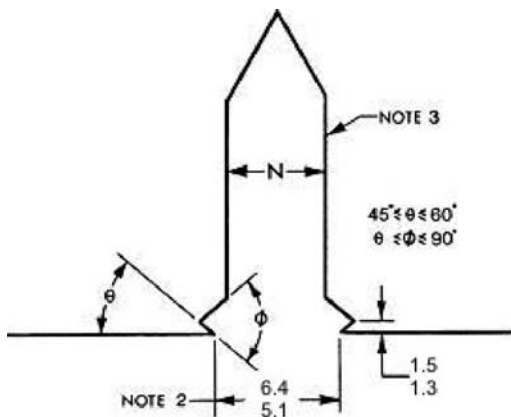

NOTE 1—Dimensions in mm.

NOTE 2—Gage length shown corresponds to clip gage spacer block dimensions shown in Annex A1, but other gage lengths may be used provided they are appropriate to the specimen (see 6.4.3).

NOTE 3—For starter notch configurations see Fig. 5.

Inch-Pound Units Equivalents				
mm	1.3	1.5	5.08	6.35
in.	0.050	0.060	0.200	0.250

FIG. 3 Example of Integral Knife Edge Design

0.0068 to 0.0071	38	1½
0.0071 to 0.0075	32	1¼
0.0075 to 0.0080	25	1
0.0080 to 0.0085	19	¾
0.0085 to 0.0100	13	½
0.0100 or greater	6.4	¼

When it has been established that  $2.5(K_{Ic}/\sigma_{YS})^2$  is substantially less than the minimum recommended ligament size given in the preceding table, then a correspondingly smaller specimen can be used.

**7.2 Specimen Configurations**—Recommended specimen configurations are shown in Figs. A3.1-A6.1 and Fig. A7.1.

**7.2.1 Specimen Proportions**—Crack size,  $a$ , is nominally between 0.45 and 0.55 times the width,  $W$ . Bend specimens can have a width to thickness,  $W/B$ , ratio of  $1 \leq W/B \leq 4$ . Tension specimen configurations can be  $2 \leq W/B \leq 4$ .

**7.2.1.1 Recommended Proportions**—It is recommended that the thickness,  $B$ , is nominally one-half the specimen width,  $W$  (that is,  $W/B = 2$ ). Likewise, the crack size,  $a$ , should be nominally equal to one-half the width,  $W$  (that is  $a/W = 1/2$ ).

NOTE 3—Alternative  $W/B$  ratios different from the recommended ratio

in 7.2.1.1 but still meeting the requirements in 7.2.1 are sometimes useful, especially for quality control or lot releases purposes, because they allow a continuous range of product thicknesses to be tested using a discrete number of specimen widths while still maintaining specimens of full product thickness. However, because specimen width influences the amount of crack extension corresponding to the 95 % slope,  $K_{Ic}$  obtained with alternative  $W/B$  ratios may not agree with those obtained using the recommended  $W/B$  ratio, particularly in products exhibiting a Type I force-CMOD record (6). As an example, a specimen with the recommended proportion  $W/B = 2$  would tend to yield a lower  $K_{Ic}$  than a specimen with an alternative proportion  $W/B = 4$ . Also, because a shorter ligament length may hinder resistance curve development, an alternative specimen with  $W/B < 2$  (allowed only for bend specimens) may pass the  $P_{max}/P_Q$  requirement, while a specimen with the recommended  $W/B$  ratio would fail. Conversely, an alternative specimen with  $W/B > 2$  (allowed in both tension and bend specimens) may fail the  $P_{max}/P_Q$  requirement, while a specimen with the recommended  $W/B$  would pass.

**7.2.2 Alternative Specimens**—In certain cases it may be necessary or desirable to use specimens having  $W/B$  ratios other than that specified in 7.2.1. Alternative  $W/B$  ratios and side-grooved specimens are allowed as specified in 7.2.1.1 and 7.2.2.1. These alternative specimens shall have the same crack length-to-specimen width ratio as the standard specimen.

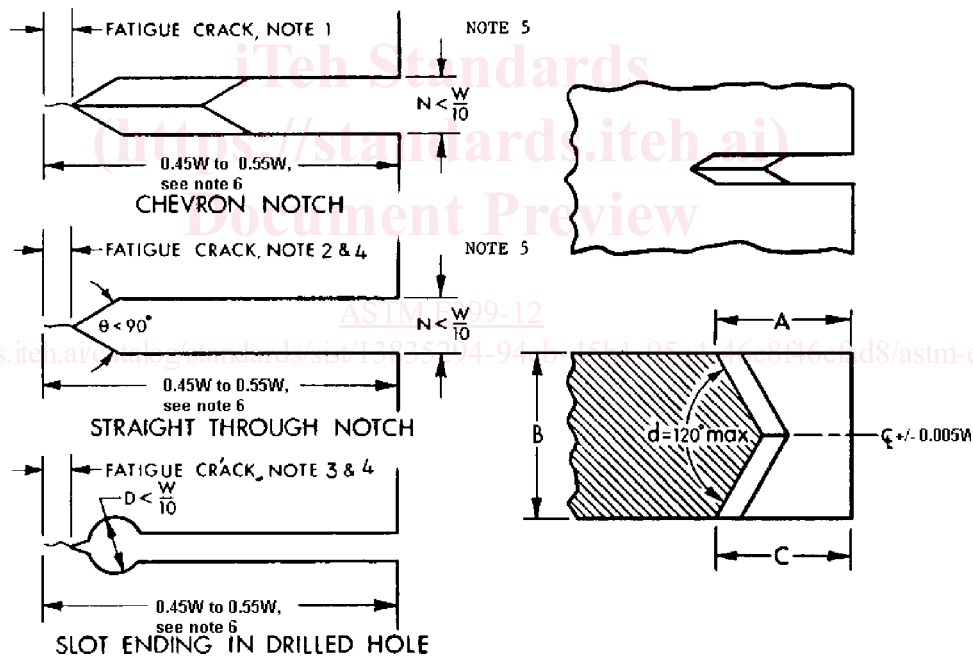

(a) Starter Notches and Fatigue Cracks

(b) Detail of Chevron Notch

- Note 1—For a chevron crack starter notch the fatigue crack shall emerge on both surfaces of the specimen.
- Note 2—Fatigue crack extension on each surface of the specimen containing a straight-through notch shall be at least 0.025  $W$  or 1.3 mm (0.050 in.), whichever is larger.
- Note 3—Fatigue crack extension on each surface of the specimen from the stress raiser tipping the hole shall be at least 0.5  $D$  or 1.3 mm (0.050 in.), whichever is larger.
- Note 4—Crack starter notch shall be perpendicular to the specimen surfaces and to the intended direction of crack propagation within  $\pm 2^\circ$ .
- Note 5—Notch width  $N$  need not be less than 1.6 mm ( $1/16$  in.).
- Note 6—From notched edge or centerline of loading holes, as appropriate.

- Note 1— $A = C$  within 0.010  $W$ .
- Note 2—Cutter tip angle  $90^\circ$  max.
- Note 3—Radius at chevron notch bottom 0.25 mm (0.010 in.) max.

FIG. 5 Crack Starter Notch and Fatigue Crack Configurations

7.2.2.1 *Alternative Side-Grooved Specimens*—For the compact C(T) and the bend SE(B) specimen configurations side-grooving is allowed as an alternative to plain-sided specimens. The total thickness reduction shall not exceed  $0.25 B$ . A total reduction of  $0.20 B$  has been found to work well (7) for many materials and is recommended (10% per side). Any included angle less than  $90^\circ$  is allowed. The root radius shall be  $0.5 \pm 0.2$  mm ( $0.02 \pm 0.01$  in.). Pre-cracking prior to the side-grooving operation is recommended to produce nearly straight fatigue precrack fronts.  $B_N$  is the minimum thickness measured at the roots of the side grooves. The root of the side groove shall be located along the specimen centerline. Fig. 6 is a schematic showing an example cross section of an alternative side grooved specimen.

NOTE 4—Side-grooves increase the level of constraint with respect to the recommended specimen. The increased constraint promotes a more uniform stress state along the crack front and inhibits shear lip development. As a result, the  $K_{Ic}$  value from a side-grooved specimen is expected to be lower than the  $K_{Ic}$  obtained from the recommended specimen, particularly for thin products or products exhibiting Type I behavior. The value of  $K_{Ic}$  from a side-grooved specimen may better represent the fracture toughness of the material in structural situations where plasticity is more highly constrained by the crack front geometry such as may be the case for a surface or corner crack, or by structural details such as keyways, radii, notches, etc. The value of  $K_{Ic}$  from the recommended specimen may better represent the fracture toughness of the material in structural situations where surface plasticity and shear lip development is not constrained such as a through crack in a region of uniform thickness. Side-grooving increases the likelihood of meeting the  $P_{max}/P_Q$  requirement, enabling a valid  $K_{Ic}$  to be obtained in products for which it would not be possible using the recommended specimen. Side grooving after precracking beneficially removes a portion of the non-linear crack front at the ends of the crack front, thus increasing the likelihood of meeting crack front straightness requirements. However, side grooving may also remove material that influences service performance. This is often true for cast parts and those for which thermo-mechanical working is part of the heat treating cycle. The increased constraint also can lead to increased likelihood of material delamination, for instance, in the plane of the specimen, which could lead to test results different from those obtained from plane-sided specimens.

NOTE 5—No interlaboratory ‘round robin’ test program has yet been conducted to compare the performance of plain-sided and side-grooved specimens. However, the results of several studies (7) indicate that  $K_{Ic}$  from side-grooved specimens is zero to 10 % less than that of plain-sided specimens, the difference increasing with increasing material toughness. The within-laboratory repeatability was determined according to the conditions in Terminology E456 and the results are presented in 11.3.

7.2.2.2 For lot acceptance testing, side-grooved specimens shall not be used unless specifically allowed by the product specification or by agreement between producer and user.

7.3 *Specimen Preparation*—All specimens shall be tested in the finally heat-treated, mechanically-worked, and environmentally-conditioned state. Specimens shall normally be machined in this final state. However, for material that cannot be machined in the final condition, the final treatment may be carried out after machining provided that the required dimensions and tolerances on specimen size, shape, and overall finish are met (see specimen drawings of Figs. A3.1-A6.1 and Fig. A7.1), and that full account is taken of the effects of specimen size on metallurgical condition induced by certain heat treatment procedures; for example, water quenching of steels.

7.3.1 *Fatigue Crack Starter Notch*—Three fatigue crack starter notch configurations are shown in Fig. 5. To facilitate fatigue precracking at low stress intensity levels, the suggested root radius for a straight-through slot terminating in a V-notch is 0.08 mm (0.003 in.) or less. For the chevron form of notch, the suggested root radius is 0.25 mm (0.010 in.) or less. For the slot ending in a drilled hole, it is necessary to provide a sharp stress raiser at the end of the hole. Care shall be taken to ensure that this stress raiser is so located that the crack plane orientation requirements of 8.2.4 can be met.

7.3.2 *Fatigue Precracking*—Fatigue precracking procedures are described in Annex A8. Fatigue cycling is continued until a crack is produced that satisfies the requirements of 7.3.2.1 and 7.3.2.2 that follow.

7.3.2.1 Crack size (total size of crack starter plus fatigue crack) shall be between  $0.45W$  and  $0.55W$ .

7.3.2.2 The size of the fatigue crack on each face of the specimen shall not be less than the larger of  $0.025W$  or 1.3 mm (0.050 in.) for the straight-through crack starter configuration, not less than the larger of  $0.5D$  or 1.3 mm (0.050 in.) for the slot ending in a hole (of diameter  $D < W/10$ ), and need only emerge from the chevron starter configuration.

8. General Procedure

8.1 *Number of Tests*—It is recommended that triplicate tests, minimum, be made for each material condition.

8.2 *Specimen Measurement*—Specimen dimensions shall conform to the drawings of Figs. A3.1-A6.1 and Fig. A7.1. Measurements essential to the calculation of  $K_{Ic}$  are specimen thickness,  $B$  (and in the case of side-grooved alternative specimens,  $B_N$ ), crack size,  $a$ , and width,  $W$ .

8.2.1 Specimen thickness,  $B$  (and in the case of side-grooved alternative specimens,  $B_N$ ), shall be measured before

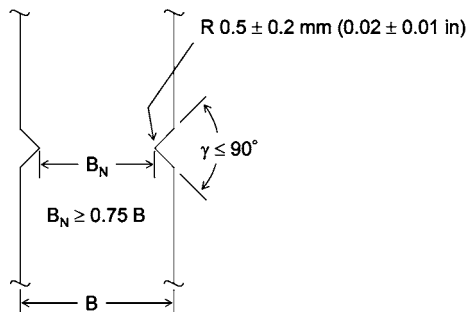

FIG. 6 Schematic of Side Groove Configuration



testing to the nearest 0.03 mm (0.001 in.) or to 0.1 %, whichever is larger. For plain-sided specimens,  $B$  shall be measured adjacent the notch. For side-grooved specimens,  $B_N$  shall be measured at the root of the notch and  $B$  adjacent the notch.

NOTE 6—For plane-sided specimens the value of  $B_N$  is equal to the thickness  $B$ .

8.2.2 Specimen width,  $W$ , shall be measured, in conformance with the procedure of the annex appropriate to the specimen configuration, to the nearest 0.03 mm (0.001 in.) or 0.1 %, whichever is larger, at not less than three positions near the notch location, and the average value recorded.

8.2.3 Specimen crack size,  $a$ , shall be measured after fracture to the nearest 0.5 % at mid-thickness and the two quarter-thickness points (based on  $B$  for plain-sided specimens and  $B_N$  for side-grooved specimens). The average of these three measurements shall be taken as the crack size,  $a$ . The difference between any two of the three crack size measurements shall not exceed 10 % of the average. The crack size shall be measured also at each surface. For the straight-through notch starter configuration, no part of the crack front shall be closer to the machined starter notch than  $0.025W$  or 1.3 mm (0.050 in.), whichever is larger; furthermore, neither surface crack size measurement shall differ from the average crack size by more than 15 % and their difference shall not exceed 10 % of the average crack size. For the chevron notch starter configuration, the fatigue crack shall emerge from the chevron on both surfaces; furthermore, neither surface crack size measurement shall differ from the average crack size by more than 15 %, and their difference shall not exceed 10 % of the average crack size.

8.2.4 The plane of the fatigue precrack and subsequent 2 % crack extension (in the central flat fracture area; that is, excluding surface shear lips) shall be parallel to the plane of the starter notch to  $\pm 10^\circ$ . For side-grooved specimens, the plane of the fatigue precrack and subsequent 2 % crack extension shall be within the root of the side-groove.

8.2.5 There shall be no evidence of multiple cracking (that is, more than one crack) (8).

8.3 *Loading Rate*—For conventional (quasi-static) tests, the specimen shall be loaded such that the rate of increase of stress-intensity factor is between 0.55 and 2.75 MPa $\sqrt{\text{m/s}}$  (30 and 150 ksi $\sqrt{\text{in./min}}$ ) during the initial elastic displacement. Loading rates corresponding to these stress-intensity factor rates are given in the Annex appropriate to the specimen being tested. For rapid-force tests, loading rates are to be as specified in Annex A10.

8.4 *Test Record*—A record shall be made of the output of the force-sensing transducer versus the output of the displacement gage. The data acquisition system shall be set such that not less than 50 % of full range is used for the test record. If an autographic recorder is used, it shall be adjusted such that the slope of the initial portion of the force-CMOD record is between 0.7 and 1.5. Alternatively, if a computer data acquisition system is used, it shall be programmed to capture enough data to permit the calculations of Section 9.

8.4.1 The test shall be continued until the specimen can sustain no further increase in applied force. The maximum force ( $P_{max}$ ) shall be noted and recorded.

## 9. Calculation and Interpretation of Results

9.1 *Interpretation of Test Record and Calculation of  $K_{Ic}$* —In order to substantiate the validity of a  $K_{Ic}$  determination, it is first necessary to calculate a conditional result,  $K_Q$ , which involves a construction on the test record, and then to determine whether this result is consistent with the size and yield strength of the specimen according to 7.1. The procedure is as follows:

9.1.1 When an autographic recorder is used, the conditional value  $P_Q$  is determined by drawing the secant line  $OP_5$ , (see Fig. 7) through the origin (point  $O$ ) of the test record with slope  $(P/V)_5$  equal to  $0.95(P/V)_o$ , where  $(P/V)_o$  is the slope of the tangent  $OA$  to the initial linear portion of the record (Note 7). In practice the origin (point  $O$ ) is not necessarily at the intersection of the displacement- and force-axes. The point  $O$  lies on the best fit line through the initial linear portion of the record and at the intersection of the best fit line with the displacement-axis. Thus, in calculating the secant line  $OP_5$ , the rotation point of the slope adjustment should be at the intersection of the line  $OA$  with the displacement-axis. The force  $P_Q$  is then defined as follows: if the force at every point on the record which precedes  $P_5$  is lower than  $P_5$  (Fig. 7, Type I), then  $P_5$  is  $P_Q$ ; if, however, there is a maximum force preceding  $P_5$  which exceeds it (Fig. 7, Types II and III), then this maximum force is  $P_Q$ .

NOTE 7—Slight initial nonlinearity of the test record is frequently observed, and is to be ignored. However, it is important to establish the initial slope of the record with high precision. Therefore it is advisable to minimize this nonlinearity by preliminarily loading the specimen to a maximum force corresponding to a stress-intensity factor level not exceeding that used in the final stage of fatigue cracking, then unloading.

NOTE 8—Residual stresses can adversely affect the indicated  $K_Q$  and  $K_{Ic}$  values. The applied loading is superimposed on the residual stresses, resulting in a total crack tip stress-intensity different from that based solely on the externally applied forces. In addition, residual stresses will likely redistribute during machining when the specimen is extracted from the host material. Hence, the magnitude of their influence on  $K_Q$  and  $K_{Ic}$  in the test specimen may be quite different from that in the original or finish machined product (see also 5.1.6.)

9.1.2 When a computer data acquisition system is used, the data reduction program shall determine the same forces ( $P_Q$  and  $P_{max}$ ) as above. The algorithms for doing this are discretionary.

9.1.3 The ratio  $P_{max}/P_Q$ , where  $P_{max}$  is the maximum force the specimen was able to sustain (see 8.4.1), shall be calculated. If this ratio does not exceed 1.10, proceed to calculate  $K_Q$  as described in the Annex appropriate to the specimen configuration. If  $P_{max}/P_Q$  does exceed 1.10, then the test is not a valid  $K_{Ic}$  test and the user is referred to Test Method E1820 on elastic-plastic fracture toughness.

9.1.4 The value  $2.5(K_Q/\sigma_{YS})^2$ , where  $\sigma_{YS}$  is the 0.2 % offset yield strength in tension (see Test Methods E8/E8M), shall be calculated. If this quantity is less than the specimen ligament size,  $W-a$  then  $K_Q$  is equal to  $K_{Ic}$ . Otherwise, the test is not a valid  $K_{Ic}$  test. Expressions for calculating  $K_Q$  are given in the Annexes for each specified specimen configuration.

9.1.5 If the test result fails to meet the requirements of 9.1.3 or 9.1.4, or both, it will be necessary to use a larger specimen to determine  $K_{Ic}$ .

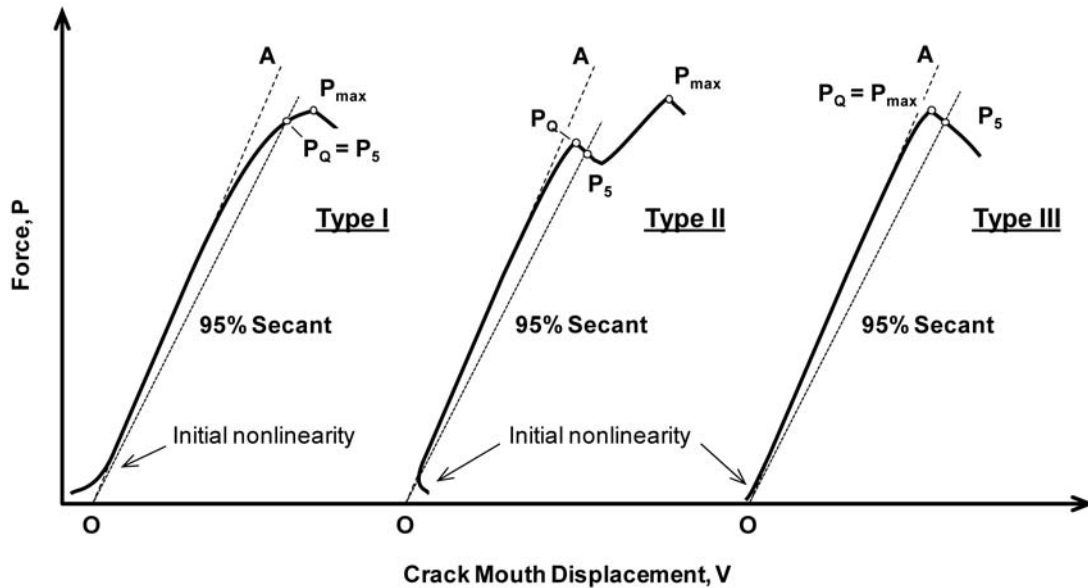

FIG. 7 Principal Types of Force-Displacement (CMOD) Records

## 10. Report

10.1 The specimen configuration code shown on the specimen drawing (in the appropriate Annex) shall be reported. This code shall be followed with the loading code (T for tension, B for bending) and the code for crack plane orientation (see 3.1.3). The latter two codes shall appear in separate parentheses. As an example, a test result obtained using the compact specimen (see Annex A4) might be designated as follows: C(T)(S-T). The first letter (C) indicates the specimen to be a compact configuration. The second letter (T) denotes the loading as tension. The first of the two letters in the last bracket (S) indicates the normal to the crack plane to be normal to the direction of principal deformation. The second of these letters (T) indicates the intended direction of crack extension to be parallel with the direction of least deformation. For cylindrical sections, where grain flow can be in the longitudinal, radial or circumferential direction, the direction of maximum grain flow shall be reported when the direction is known (see 3.1.3).

10.2 The following information shall be additionally reported for each specimen tested:

10.2.1 Characterization of the material (alloy code or chemistry and metallurgical condition) and product form (sheet, plate, bar, forging, casting, and so forth) tested.

10.2.2 Specimen thickness,  $B$ , for plain-sided configurations. For side-grooved specimens,  $B$ ,  $B_N$  and  $(B \cdot B_N)^{1/2}$ .

10.2.3 Specimen width (depth),  $W$ .

10.2.3.1 Loading hole offset,  $X$ , for the arc-shaped tension specimen.

10.2.3.2 Outer and inner radii,  $r_2$  and  $r_1$ , for arc-shaped specimens.

10.2.4 Fatigue precracking conditions, specifically the maximum stress-intensity factor,  $K_{max}$ , stress-intensity factor range,  $\Delta K_I$ , and number of cycles for the final 2.5 % of the overall crack size,  $a$  (size of notch plus fatigue crack extension).

10.2.5 Crack size measurements, after fracture, at mid-thickness and the two quarter-thickness positions on the crack front, as well as at the intersection of the crack front with the specimen surface.

10.2.6 Test temperature.

10.2.7 Relative humidity as determined by Test Method E337.

10.2.8 Loading rate in terms of  $\dot{K}_I$  (change in stress-intensity factor per unit time) (3).

10.2.9 Force-versus-crack mouth opening displacement (CMOD) record and associated calculations.

10.2.10 Yield strength as determined by Test Methods E8/E8M.

10.2.11  $K_{Ic}$  (or,  $K_Q$  followed by the parenthetical statement “invalid according to Sections(s) \_\_\_\_\_ of Test Method E399”).

10.2.12  $P_{max}/P_Q$ .

10.3 Fig. 8 is a convenient format for tabulating the information required in 10.1 and 10.2.

## 11. Precision and Bias

11.1 The precision of  $K_{Ic}$  measurements has been examined in several interlaboratory round-robin studies. Selected aluminum alloys and high-strength steels were tested using standard bend SE(B) (9), compact C(T) (10), and arc-shaped tension A(T) (11) specimen configurations. The results are summarized in 11.3 (Precision) and 11.5 (Bias) that follow. Not all of the results reported satisfied all of the validity requirements of this test method. Statistical analysis (10, 11, 12) was used to exclude data that were likely influenced by deviations from the validity requirements. No round-robin program has been conducted for the disk-shaped compact DC(T) specimen configuration, but limited data for that specimen configuration are compared with data for other specimen configurations in Annex A5. Round-robin studies specific to the quasi-static

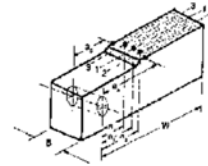

Figure 7.  $K_{Ic}$  Data Sheet (Example)

Material/Form \_\_\_\_\_ Heat Treat \_\_\_\_\_  
 Specimen I.D. \_\_\_\_\_ Specimen Type \_\_\_\_\_

Date / /

PARTICULARS	DATA	REF. PARAGRAPH	FRACTURE TEST	DATA	REF. PARAGRAPH
Crack Plane Orientation		3.1.3	Crack Size		
Material Yield Strength, MPa (ksi)		7.1.1, A10.2.1, A10.7.3	- At Center of Crack Front ( $a_1$ ) mm (in.)		8.2.3
Specimen Thickness, mm (in.)		8.2.1	- At Right of Center ( $a_2$ ) mm (in.)		8.2.3
Specimen Width, mm (in.)		8.2.2	- At Left of Center ( $a_3$ ) mm (in.)		8.2.3
---for SE (B)		A3.4.1	- At Right Surface ( $a_4$ ) mm (in.)		8.2.3
---for C (T)		A4.4.1	- At Left Surface ( $a_5$ ) mm (in.)		8.2.3
---for DC (T)		A5.4.1.2	Crack Plane Symmetry		8.2.4
Arc-Shaped Tension A (T) Specimen:			Loading Rate MPa√m/s (ksi√in./min)		8.3
---Width, W, mm (in.)		A6.4.1	Test Temperature °C (°F)		10.2.6
---Loading Plate Offset, X, mm (in.)		A6.4.1	Relatively Humidity, %		10.2.7
---Outer and Inner Radii $r_1$ and $r_2$ , mm (in.)		A6.4.1	Force-CMOD Record		8.4, 9.1
Arc-Shaped Bend A (B) Specimen:					
---Width, W, mm (in.)		A7.4.1			
---Loading Plate Offset, X, mm (in.)		A7.4.1			
---Outer and Inner Radii $r_1$ and $r_2$ , mm (in.)		A7.4.1			
FATIGUE PRECRACKING	DATA	REF. PARAGRAPH	K CALCULATION	DATA	REF. PARAGRAPH
--- $K_{max}/E < 0.00032 \sqrt{m}$ (0.002√in.)		A8.3.3	$P_{max}/P_Q < 1.1$		9.1.3
--- $K_{max} < 0.6 K_Q$ MPa√m (ksi√in.)		A8.3.3	--- $2.5(K_{Ic}/\sigma_{ys})^2$ , MPa√m (ksi√in.)		7.1, 9.1.4
--- $K_{max} < 0.8 K_{Ic}$ MPa√m (ksi√in.)		A8.3.3	--- $K_Q$ SE(B) MPa√m (ksi√in.)		A3.5.3
-for Test at Temperature $T_2$ :			--- $K_Q$ C(T) MPa√m (ksi√in.)		A4.5.3
- $K_{MAX} T_1 < 0.6(\sigma_{ysT1}/\sigma_{ysT2}) K_Q(T_2)$ MPa√m (ksi√in.)		A8.4.4	--- $K_Q$ DC(T) MPa√m (ksi√in.)		A5.5.3
Crack Size – Starter Slot Plus Fatigue Precrack:			--- $K_Q$ A(T) MPa√m (ksi√in.)		A6.5.3
--- $a = 0.50W$ mm (in.)		7.3.2.1, A8.3.2	--- $K_Q$ A(B) MPa√m (ksi√in.)		A7.5.3
--- $K_{MAX}, \Delta K$ MPa√m (ksi√in.)		A8.1.3	Invalid according to E 399 Section(s):		10.2.11
			Valid $K_{Ic}$ MPa√m (ksi√in.):		10.2.11

FIG. 8 Suggested Form of Table for Reporting Information Listed in 10.1 and 10.2

testing of beryllium and the dynamic testing of a strain-rate sensitive steel, and which involved special testing procedures, are presented in Annex A9 and Annex A10.

11.2 It should be emphasized that the measures of precision given in Table 1, Table 2, and Table 3 apply to alloys that essentially exhibited no transitional fracture behavior with temperature or strain rate under the specific test conditions of the interlaboratory studies.

11.3 Precision—The precision of  $K_{Ic}$  determination is affected by errors in the measurement of test force and specimen dimensions, especially the crack size. This test method specifies a precision for each measured quantity and, based on these

specifications and the round-robin results, a theoretical precision is rendered (13). Analysis of the method’s specifications suggests that precision decreases with increasing relative crack size, more for the bend than for the compact configuration. In practice, the precision of  $K_{Ic}$  measurement may depend to an unknown extent on the characteristics of the test record and analysis skills of the laboratory personnel. It is possible to derive useful information concerning the precision of  $K_{Ic}$  measurement from three round-robin programs (10, 11, 12) as described below. Results for bend, compact, and arc-shaped specimen configurations were obtained for several aluminum alloys and high strength steels. The materials were chosen for

TABLE 1 Precision Using SE(B) Specimens (Nominal Crack Size-to-Specimen Width Ratio  $a/W = 0.5$ )

Parameter	Material and Yield Strength	Average	Repeatability Standard Deviation	Reproducibility Standard Deviation	Repeatability Limit	Reproducibility Limit
$K_{Ic}$ (MPa√m)	2219–T851 (353 MPa)	35.94	2.27	2.54	6.37	7.11
	Maraging 18Ni (1903 MPa)	57.02	2.15	4.03	6.03	11.27
	4340–500 F (1641 MPa)	48.55	1.86	2.17	5.20	6.07
	4340–800 F (1420 MPa)	87.76	3.03	4.13	8.49	11.56