



Designation: **F1800–07 F1800 – 12**

# Standard Test Method Practice for Cyclic Fatigue Testing of Metal Tibial Tray Components of Total Knee Joint Replacements<sup>1</sup>

This standard is issued under the fixed designation F1800; the number immediately following the designation indicates the year of original adoption or, in the case of revision, the year of last revision. A number in parentheses indicates the year of last reapproval. A superscript epsilon ( $\epsilon$ ) indicates an editorial change since the last revision or reapproval.

## 1. Scope

1.1 This ~~test method practice~~ covers a procedure for the fatigue testing of metallic tibial trays used in knee joint replacements. This ~~test method practice~~ covers the procedures for the performance of fatigue tests on metallic tibial components using a cyclic, constant-amplitude force. It applies to tibial trays which cover both the medial and lateral plateaus of the tibia. This ~~test method practice~~ may require modifications to accommodate other tibial tray designs.

1.2 This ~~test method practice~~ is intended to provide useful, consistent, and reproducible information about the fatigue performance of metallic tibial trays with one unsupported condyle.

1.3 The values stated in SI units are to be regarded as the standard. ~~The inch-pound units given in parentheses are for information only. No other units of measurement are included in this standard.~~

1.4 *This standard does not purport to address all of the safety concerns, if any, associated with its use. It is the responsibility of the user of this standard to establish appropriate safety and health practices and determine the applicability of regulatory limitations prior to use.*

## 2. Referenced Documents

2.1 *ASTM Standards:*<sup>2</sup>

E4 Practices for Force Verification of Testing Machines

E467 Practice for Verification of Constant Amplitude Dynamic Forces in an Axial Fatigue Testing System

E468 Practice for Presentation of Constant Amplitude Fatigue Test Results for Metallic Materials

E1150 Definitions of Terms Relating to Fatigue (Withdrawn 1996)<sup>3</sup>

## 3. Terminology

3.1 *Definitions:* [standards.iteh.ai/catalog/standards/sist/bf1ff6cb-a8f9-43c5-9b81-ce5b16c0d6fa/astm-f1800-12](https://standards.iteh.ai/catalog/standards/sist/bf1ff6cb-a8f9-43c5-9b81-ce5b16c0d6fa/astm-f1800-12)

3.1.1 *R value*—The R value is the ratio of the minimum load to the maximum load.

$$R = \frac{\text{minimum load}}{\text{maximum load}} \quad (1)$$

3.2 *Definitions of Terms Specific to This Standard:*

3.2.1 *anteroposterior centerline*—a line that passes through the center of the tibial tray, parallel to the sagittal plane and perpendicular to the line of load application. For asymmetric tibial tray designs, the appropriate center of the tibial tray shall be determined by the investigator and the rationale reported.

3.2.2 *fixture centerline*—a line that passes through the center of the fixture, parallel to the anteroposterior centerline. This line represents the separation between the supported and unsupported portions of the test fixture.

3.2.3 *mediolateral centerline*—a line that passes through the center of the tibial tray, parallel to the coronal, or frontal, plane and perpendicular to the line of load application. For asymmetric tibial tray designs, the appropriate center of the tibial tray shall be determined by the investigator and the rationale reported.

<sup>1</sup> This ~~test method practice~~ is under the jurisdiction of ASTM Committee F04 on Medical and Surgical Materials and Devices and is the direct responsibility of Subcommittee F04.22 on Arthroplasty.

Current edition approved Sept. 15, 2007 Dec. 15, 2012. Published October 2007 January 2013. Originally approved in 1997. Last previous edition approved in 2004 2007 as F1800–04 F1800–07. DOI: 10.1520/F1800-07-10.1520/F1800-12.

<sup>2</sup> For referenced ASTM standards, visit the ASTM website, www.astm.org, or contact ASTM Customer Service at service@astm.org. For *Annual Book of ASTM Standards* volume information, refer to the standard's Document Summary page on the ASTM website.

<sup>3</sup> The last approved version of this historical standard is referenced on www.astm.org.

3.2.4 *moment arm,  $d_{ap}$* —the perpendicular distance between the mediolateral centerline of the tibia component and the line of load application.

3.2.5 *moment arm,  $d_{ml}$* —the perpendicular distance between the anteroposterior centerline of the tibia component and the line of load application.

#### 4. Significance and Use

4.1 This test method practice can be used to describe the effects of materials, manufacturing, and design variables on the fatigue performance of metallic tibial trays subject to cyclic loading for relatively large numbers of cycles.

4.2 The loading of tibial tray designs *in vivo* will, in general, differ from the loading defined in this test method practice. The results obtained here cannot be used to directly predict *in vivo* performance. However, this test method practice is designed to allow for comparisons between the fatigue performance of different metallic tibial tray designs, when tested under similar conditions.

4.3 In order for fatigue data on tibial trays to be comparable, reproducible, and capable of being correlated among laboratories, it is essential that uniform procedures be established.

#### 5. Specimen Selection

5.1 The test component selected shall have the same geometry as the final product, and shall be in finished condition.

#### 6. Apparatus

6.1 The tibial tray shall be mounted as a cantilever beam (see Fig. 1 and Fig. 2). Care shall be taken to ensure that the fixation of the tibial tray does not produce abnormal stress concentrations that could change the failure mode of the part. One possible setup involving fixation of the inferior surface or clamping of the superior surface is shown in Fig. 1 and Fig. 2. If necessary, bone cement or other high strength epoxy may be used on the supported aspect of the tibial tray to prevent loosening during the test.

6.2 The tibial tray shall be positioned such that the anteroposterior centerline and the fixture centerline are aligned with an accuracy of  $\pm 1$  mm in the  $x$  direction and  $\pm 2^\circ$  in the  $x$ - $y$  plane (see Fig. 1 and Fig. 2).

6.3 When the tibial tray design includes a central keel or other prominence, the proper method for support of the keel must be determined. Depending on the tibial tray design, it may be necessary to evaluate the design with or without support of the keel (see Fig. 2). The method of supporting (or not supporting) any such feature shall be reported.

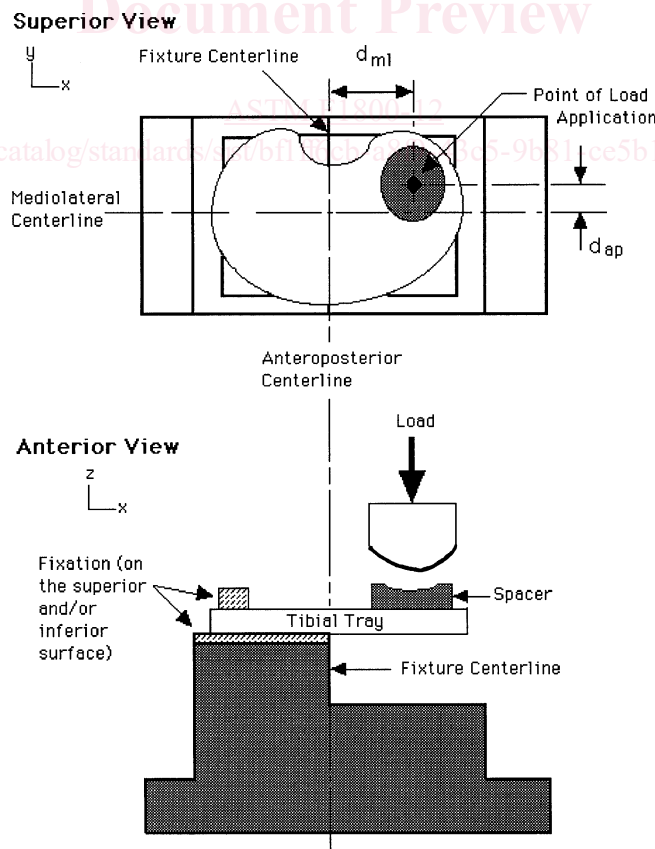

FIG. 1 Schematic of Test Setup Without a Central Keel

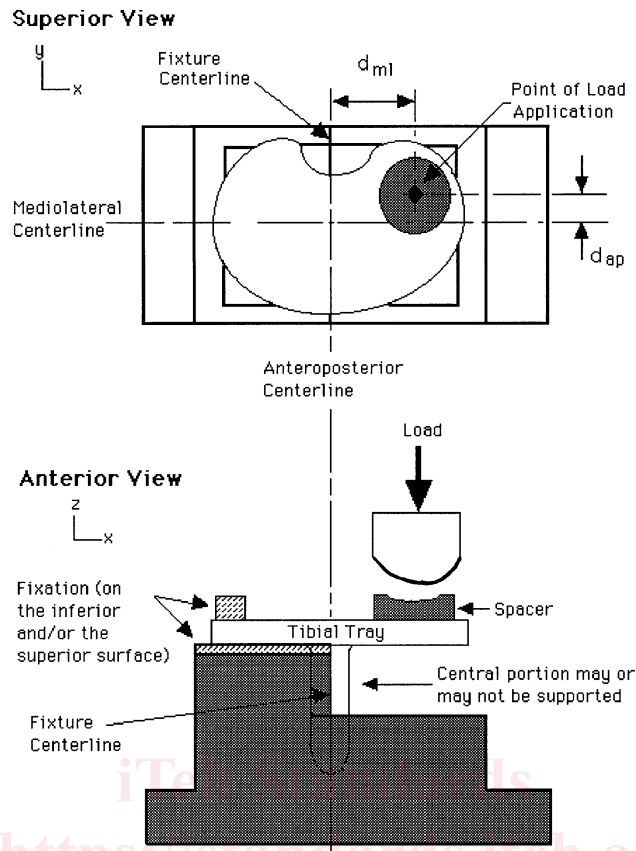

FIG. 2 Schematic of Test Setup With a Central Keel

6.4 A spacer of plastic possessing sufficient stiffness and creep resistance (for example, ultra high molecular weight polyethylene, acetal co-polymer) shall be placed between the tibial tray and the load applicator (see Fig. 3). The spacer shall contain a spherical indentation (or recess) for the spherical indenter. This recess shall be greater to or equal than the diameter of the spherical indenter and is included to minimize the chance of spacer fracture under load. The spacer shall have a minimum thickness of 6 mm (0.25 in.); mm, measured at the dome of the sphere. It is recommended that the diameter of the spacer is 13 mm (0.5 in.); mm.

NOTE 1—Actual dimensions of the spacer may vary as smaller tibial tray designs may require a smaller diameter disk.

6.4.1 The spacer shall be placed on the unsupported tibial condyle. The purpose of the spacer is to distribute load to the tibial tray condyle and to eliminate possible fretting fatigue initiated by contact between the metal indenter and the tibial tray.

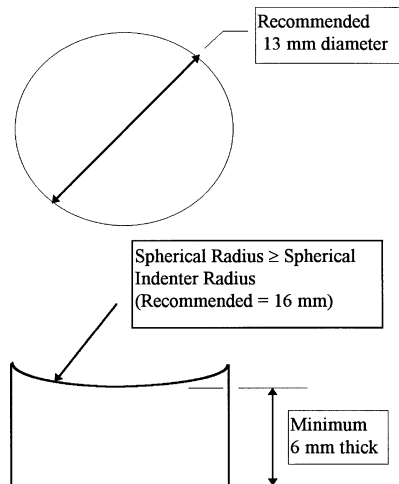

FIG. 3 Recommended Spacer Drawing