

ISO/DTS 20791-3 2022(E)

Date: 2022-08-17

ISO TC 42/WG 3

Secretariat: ANSI

Photography – Photographic reflection prints – Part 3: Evaluation of glossiness

*Photographie — Tirages photographiques par réflexion — Part 3: Évaluation de la brillance*

**Style Definition:** Heading 1: Indent: Left: 0 pt, First line: 0 pt, Tab stops: Not at 21.6 pt

**Style Definition:** Heading 2: Font: Bold, Tab stops: Not at 18 pt

**Style Definition:** Heading 3: Font: Bold

**Style Definition:** Heading 4: Font: Bold

**Style Definition:** Heading 5: Font: Bold

**Style Definition:** Heading 6: Font: Bold

**Style Definition:** ANNEX

**Style Definition:** AMEND Terms Heading: Font: Bold

**Style Definition:** AMEND Heading 1 Unnumbered: Font: Bold

iTeh STANDARD PREVIEW  
(standards.iteh.ai)

ISO/DTS 20791-3

<https://standards.iteh.ai/catalog/standards/sist/4acc38de-9ae4-4b5e-b290-9b52d1c0a99a/iso-dts-20791-3>

© ISO 2022

All rights reserved. Unless otherwise specified, or required in the context of its implementation, no part of this publication may be reproduced or utilized otherwise in any form or by any means, electronic or mechanical, including photocopying, or posting on the internet or an intranet, without prior written permission. Permission can be requested from either ISO at the address below or ISO's member body in the country of the requester.

ISO copyright office

CP 401 • Ch. de Blandonnet 8

CH-1214 Vernier, Geneva

Phone: +41 22 749 01 11

Email: [copyright@iso.org](mailto:copyright@iso.org)

Website: [www.iso.org](http://www.iso.org)

Published in Switzerland

Formatted: Pattern: Clear

Formatted: Pattern: Clear

iTeh STANDARD PREVIEW  
(standards.iteh.ai)

ISO/DTS 20791-3

<https://standards.iteh.ai/catalog/standards/sist/4acc38de-9ae4-4b5e-b290-9b52d1c0a99a/iso-dts-20791-3>

**Contents**

<b>Foreword</b> .....	<b>ii</b>
<b>Introduction</b> .....	<b>ii</b>
<b>1 Scope</b> .....	<b>2</b>
<b>2 Normative references</b> .....	<b>2</b>
<b>3 Terms and definitions</b> .....	<b>2</b>
<b>3.1 Terms</b> .....	<b>2</b>
<b>3.2 Abbreviations</b> .....	<b>2</b>
<b>4 Overview</b> .....	<b>2</b>
<b>5 Sample preparations</b> .....	<b>2</b>
<b>5.1 Test targets</b> .....	<b>2</b>
<b>5.2 Printing</b> .....	<b>2</b>
<b>5.3 Specimens</b> .....	<b>2</b>
<b>6 Measurement of specular gloss</b> .....	<b>2</b>
<b>6.1 General</b> .....	<b>2</b>
<b>6.2 Apparatus</b> .....	<b>2</b>
<b>6.3 Procedure</b> .....	<b>2</b>
<b>7 Measurement of image clarity</b> .....	<b>2</b>
<b>7.1 General</b> .....	<b>2</b>
<b>7.2 Apparatus</b> .....	<b>2</b>
<b>7.3 Procedure</b> .....	<b>2</b>
<b>8 Test report</b> .....	<b>2</b>
<b>Annex A (informative) Other properties regarding glossiness</b> .....	<b>2</b>
<b>A.1 General</b> .....	<b>2</b>
<b>A.2 Differential gloss</b> .....	<b>2</b>
<b>A.3 Gloss colour (bronzing)</b> .....	<b>2</b>
<b>A.4 Relief</b> .....	<b>2</b>
<b>A.5 Gloss streak and other gloss non-uniformity</b> .....	<b>2</b>
<b>Bibliography</b> .....	<b>2</b>
<b>Foreword</b> .....	<b>ii</b>
<b>Introduction</b> .....	<b>ii</b>

<b>1</b>	<b>Scope</b>	<b>2</b>
<b>2</b>	<b>Normative references</b>	<b>2</b>
<b>3</b>	<b>Terms and definitions</b>	<b>2</b>
<b>3.1</b>	<b>Terms</b>	<b>2</b>
<b>3.2</b>	<b>Abbreviations</b>	<b>2</b>
<b>4</b>	<b>Overview</b>	<b>2</b>
<b>5</b>	<b>Sample preparations</b>	<b>2</b>
<b>5.1</b>	<b>Test targets</b>	<b>2</b>
<b>5.2</b>	<b>Printing</b>	<b>2</b>
<b>5.3</b>	<b>Specimens</b>	<b>2</b>
<b>6</b>	<b>Measurement of specular gloss</b>	<b>2</b>
<b>6.1</b>	<b>General</b>	<b>2</b>
<b>6.2</b>	<b>Apparatus</b>	<b>2</b>
<b>6.3</b>	<b>Procedure</b>	<b>2</b>
<b>7</b>	<b>Measurement of image clarity</b>	<b>2</b>
<b>7.1</b>	<b>General</b>	<b>2</b>
<b>7.2</b>	<b>Apparatus</b>	<b>2</b>
<b>7.3</b>	<b>Procedure</b>	<b>2</b>
<b>8</b>	<b>Test report</b>	<b>2</b>
<b>Annex A (informative) Other properties regarding glossiness</b>		<b>2</b>
<b>Bibliography</b>		<b>2</b>

<https://standards.iteh.ai/catalog/standards/sist/4acc38de-9ae4-4b5e-b290-9b52d1c0a99a/iso-dts-20791-3>

## Foreword

ISO (the International Organization for Standardization) is a worldwide federation of national standards bodies (ISO member bodies). The work of preparing International Standards is normally carried out through ISO technical committees. Each member body interested in a subject for which a technical committee has been established has the right to be represented on that committee. International organizations, governmental and non-governmental, in liaison with ISO, also take part in the work. ISO collaborates closely with the International Electrotechnical Commission (IEC) on all matters of electrotechnical standardization.

The procedures used to develop this document and those intended for its further maintenance are described in the ISO/IEC Directives, Part 1. In particular, the different approval criteria needed for the different types of ISO documents should be noted. This document was drafted in accordance with the editorial rules of the ISO/IEC Directives, Part 2 (see [www.iso.org/directives](http://www.iso.org/directives)).

Attention is drawn to the possibility that some of the elements of this document may be the subject of patent rights. ISO shall not be held responsible for identifying any or all such patent rights. Details of any patent rights identified during the development of the document will be in the Introduction and/or on the ISO list of patent declarations received (see [www.iso.org/patents](http://www.iso.org/patents)).

Any trade name used in this document is information given for the convenience of users and does not constitute an endorsement.

For an explanation of the voluntary nature of standards, the meaning of ISO specific terms and expressions related to conformity assessment, as well as information about ISO's adherence to the World Trade Organization (WTO) principles in the Technical Barriers to Trade (TBT), see [www.iso.org/iso/foreword.html](http://www.iso.org/iso/foreword.html).

This document was prepared by Technical Committee ISO/TC 42, *Photography*.

A list of all parts in the ISO 20791 series can be found on the ISO website.

Any feedback or questions on this document should be directed to the user's national standards body. A complete listing of these bodies can be found at [www.iso.org/members.html](http://www.iso.org/members.html).

Formatted: Pattern: Clear

Formatted: Pattern: Clear

Formatted: Pattern: Clear

## Introduction

Glossiness is an optical property regarding reflected light from print surfaces. Many studies have been conducted on glossiness of industrial materials, and several studies have been reported on print materials as well.<sup>[4]–[6]</sup>, see References [1] to [6]. It is especially important for photographic prints with respect to printed image quality, because it has wide variety from very high glossy to dead matte surfaces. As stated in ISO/TR-20791-1,<sup>[7]</sup> several properties affect the gloss perception of photographic prints. Specular gloss and image clarity (distinctness of image) are the two major properties among them. The former relates to the perceived intensity of reflected light and the latter relates to the sharpness of reflected image. There is also a study that states that perceived glossiness of photographic prints is well represented by the combination of these two measurements, specular gloss and image sharpness<sup>[8]</sup>.

Some measurements for properties regarding glossiness have been standardized for industrial materials such as coating, plastics and papers.<sup>[9]–[13]</sup>, see References [9] to [13]. Among them, the measurement methods for coatings are standardized with specular gloss and image clarity as important properties for the reflection characteristics. Some standards for graphic printing and office printing basically refer to them while adding methods and cautions specific to each application.<sup>[14]–[15]</sup> But there has been no published standard for photographic prints.

This document provides the measurement methods of two major properties to evaluate glossiness of photographic prints: specular gloss and image clarity. The methods are based on the existing documents for coatings and plastics, and specific requirements for photographic prints are defined regarding sample preparation, measurement procedure and reporting.

Formatted: Pattern: Clear

Formatted: Pattern: Clear

Formatted: Pattern: Clear

Formatted: Pattern: Clear

Formatted: Pattern: Clear

Formatted: Pattern: Clear

Formatted: Pattern: Clear

ISO/DTS 20791-3

<https://standards.iteh.ai/catalog/standards/sist/4acc38de-9ae4-4b5e-b290-9b52d1c0a99a/iso-dts-20791-3>

## Photography – Photographic reflection prints – Part 3: Evaluation of glossiness

### 1 Scope

This document describes the characterization of glossiness of photographic reflection prints, which consists of specular gloss measurement and image clarity measurement. This document is applicable to any photographic printing technologies such as inkjet, thermal dye transfer, electrophotography and silver halide technologies.

NOTE The level of preferred glossiness depends on the application.

### 2 Normative references

The following documents are referred to in the text in such a way that some or all of their content constitutes requirements of this document. For dated references, only the edition cited applies. For undated references, the latest edition of the referenced document (including any amendments) applies.

~~<std>ISO 2813, *Paints and varnishes — Determination of gloss value at 20°, 60° and 85°*</std>~~

~~<std>ISO 17221, *Plastics — Determination of image clarity (degree of sharpness of reflected or transmitted image)*</std>~~

~~<std>ISO 18913, *Imaging materials — Permanence — Vocabulary*</std>~~

~~ISO 2813, *Paints and varnishes — Determination of gloss value at 20°, 60° and 85°*~~

~~ISO 17221, *Plastics — Determination of image clarity (degree of sharpness of reflected or transmitted image)*~~

~~ISO 18913, *Imaging materials — Permanence — Vocabulary*~~

### 3 Terms and definitions

For the purposes of this document, the following terms and definitions given in ISO 18913 and the following apply.

ISO and IEC maintain terminological databases for use in standardization at the following addresses:

— ISO Online browsing platform: available at <https://www.iso.org/obp><https://www.iso.org/obp>

— IEC Electropedia: available at <https://www.electropedia.org/><https://www.electropedia.org/>

#### 3.1 Terms

##### 3.1.1

##### **glossiness**

visual quality related to shiny and smooth appearance

Formatted: Pattern: Clear

Formatted: Pattern: Clear

Note 1 to entry: Based on this appearance, humans perceive features such as reflection characteristics and roughness of the surface of an object.

3.1.2 specular gloss

ratio of the luminous flux, reflected by the test surface into a specified aperture at the angle of specular reflection, to that from a standard specularly reflecting surface under the same conditions

[SOURCE: ISO 4046-5:2016, 5.107, modified — Note 1 to entry was deleted.]

Formatted: Pattern: Clear

Formatted: Pattern: Clear

Formatted: Pattern: Clear

Formatted: Pattern: Clear

Formatted: Pattern: Clear

3.1.3 image clarity distinctness of image DOI

degree of sharpness of an image reflected by a specimen or transmitted through a specimen

[SOURCE: ISO 17221:2014, 3.1, modified — the synonym "distinctness of image (DOI)" was added and Note 1 to entry was deleted.]

Formatted: Pattern: Clear

Formatted: Pattern: Clear

Formatted: Pattern: Clear

Formatted: Pattern: Clear

3.2 Abbreviations

C	cyan
M	magenta
Y	yellow
R	red
G	green
B	blue

iTeh STANDARD PREVIEW (standards.iteh.ai)

ISO/DTS 20791-3

https://standards.iteh.ai/catalog/standards/sist/4acc38de-9ae4-4b5e-b290-9b52d1c0a99a/iso-dts-20791-3

4 Overview

This document stipulates evaluation methods of glossiness, based on specular gloss and image clarity. Each measurement method is based on ISO 2813 and ISO 17221. Specific requirements for photographic prints are described in Clause 5 for sample preparation, Clause 6 and 7 for measurement and Clause 8 for reporting. In addition, other properties which relate to glossiness are described in Annex A.

Formatted: Pattern: Clear

Formatted: Pattern: Clear

Formatted: Pattern: Clear

Formatted: Pattern: Clear

Formatted: Pattern: Clear

Formatted: Pattern: Clear

Formatted: Pattern: Clear

Formatted: Pattern: Clear

The purpose of this document is to characterize the glossiness of photographic prints. Since the level of preferred glossiness depends on the application, this document does not discuss performance superiority or inferiority. The methods in this document are intended to be used for product design and product comparison and are not intended to be used for daily quality assurance in manufacturing.

5 Sample preparations

5.1 Test targets

At least white (D\_min) and black patches shall be printed for measurement. Additional colours such as cyan\_(C), magenta\_(M), yellow\_(Y), red\_(R), green\_(G), blue\_(B) and grey are recommended to evaluate the effects of colour or density on measured properties. The sRGB encoded patch values described in ISO 18944 can be applied to test targets for digital printers. Patch size for measurements shall be not

Formatted: Font: Italic

Formatted: Pattern: Clear

Formatted: Pattern: Clear



less than 25 mm x 25 mm. Examples of test targets are shown in Figure 1. Figure 1(a) can be used for both colour and monochrome prints.

NOTE A larger patch size is sometimes necessary for the measurements of specular gloss especially at higher angle such as 85°. The manufacturer of each measuring instrument usually provides information about the aperture size and/or the minimum patch size.

Formatted: Pattern: Clear  
Formatted: Pattern: Clear  
Formatted: cite\_fig

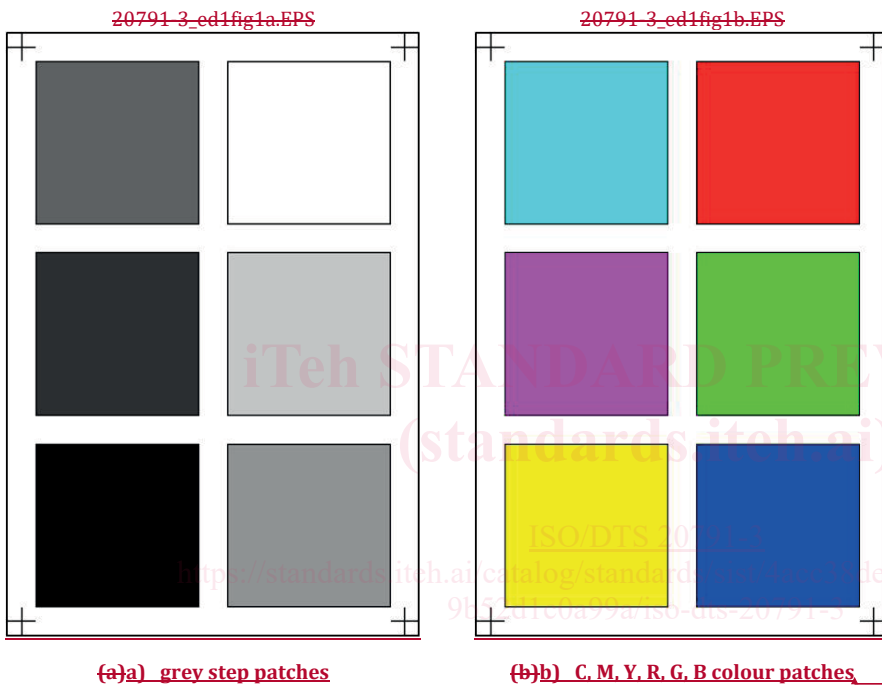

Figure 1 — Examples of test targets: (a) grey step patches, (b) C, M, Y, R, G, B colour patches

Formatted: Table body (+), Adjust space between Latin and Asian text, Adjust space between Asian text and numbers  
Formatted: French (Switzerland)

### 5.2 Printing

The standard ambient environmental condition for printing shall be a temperature of 23 °C ± 3 °C, a relative humidity of 50 % RH ± 10 % RH and an air pressure of 101 kPa ± 20 kPa. If it is not possible to conduct the test under the standard environmental condition, the temperature and humidity shall be reported.

Aqueous and solvent inkjet prints, and prints of any type that require curing/stabilization/dry-down shall be conditioned until the curing process is finished. If the duration of curing is unknown, prints should be conditioned for at least two weeks after printing, in an environment with a temperature of 23 °C ± 2 °C, with a relative humidity of 50 % RH ± 5 % RH.

### 5.3 Specimens

The size of specimen shall not be less than 30 mm x 30 mm to cover the minimum size of 25 mm x 25 mm for a single test patch.

## ISO/DTS 20791-3:2022(E)

In the case of large size prints, they are cut to fit in the above size before measurement.

**NOTE** The upper and lower limits of the size, where the sample is stably held, can vary depending on thickness of the sample and structure of the sample holder. The specification of the instrument can be referred.

It is recommended that prints be backed to keep the surface of prints flat during the measurement. Paper boards, plastic plate and metal plates can be used as backing materials. Black coloured boards are preferable to minimize the effects on the measurements. Backing materials shall be reported if they are applied for measurements.

## 6 Measurement of specular gloss

### 6.1 General

Specular gloss is relating to the luminous flux reflected from a specimen in specular direction for a specified reflection angle. It is expressed as a ratio of a specimen and a reference glass surface and the ratio multiplied by 100 is treated as a measured value. A glass surface with a refractive index of 1,567 at a wavelength of 587,6 nm is assumed to be the reference for the measurement. The methods in ISO-2813 are applied.

### 6.2 Apparatus

A glossmeter, as stipulated in ISO-2813, shall be used. It consists of a light source unit, a sample stage and a receptor unit, and has an instrument to adjust the incident angle and the receptor angle. The course of beam of the glossmeter is illustrated in Figure 2. The apparatus shall have the geometry characteristics and structure specified in ISO-2813.

20791\_3\_ed1fig2.EPS

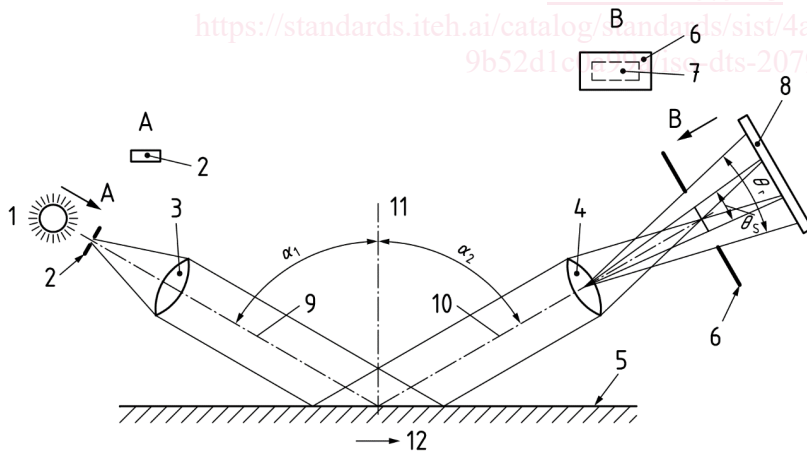

#### Key

- |                         |  |
|-------------------------|--|
| 1 light source (source) | 9 optical axis of the incident beam    |
| 2 source image aperture | 10 optical axis of the receptor beam   |
| 3 source lens           | 11 surface normal of the test specimen |
| 4 receptor lens         | 12 direction of measurement            |

Formatted: Pattern: Clear

Formatted: Pattern: Clear

Formatted: Pattern: Clear

Formatted: Pattern: Clear

Formatted: Pattern: Clear

Formatted: Pattern: Clear

Formatted: Pattern: Clear