**Tools for pressing — Guide pillars —
Part 3:
Type B, end-locking pillars**

*Outillage de presse — Colonnes de guidage —
Partie 3: Type B, colonnes à retenue médiane*

iTeh STANDARD PREVIEW
(standards.iteh.ai)

[ISO 9182-3:2023](https://standards.iteh.ai/catalog/standards/sist/f89d5ee5-f382-4bf1-acec-0df7af6b6f14/iso-9182-3-2023)

<https://standards.iteh.ai/catalog/standards/sist/f89d5ee5-f382-4bf1-acec-0df7af6b6f14/iso-9182-3-2023>



iTeh STANDARD PREVIEW
(standards.iteh.ai)

ISO 9182-3:2023

<https://standards.iteh.ai/catalog/standards/sist/f89d5ee5-f382-4bf1-acec-0df7af6b6f14/iso-9182-3-2023>



COPYRIGHT PROTECTED DOCUMENT

© ISO 2023

All rights reserved. Unless otherwise specified, or required in the context of its implementation, no part of this publication may be reproduced or utilized otherwise in any form or by any means, electronic or mechanical, including photocopying, or posting on the internet or an intranet, without prior written permission. Permission can be requested from either ISO at the address below or ISO's member body in the country of the requester.

ISO copyright office
CP 401 • Ch. de Blandonnet 8
CH-1214 Vernier, Geneva
Phone: +41 22 749 01 11
Email: copyright@iso.org
Website: www.iso.org

Published in Switzerland

Contents

	Page
Foreword.....	iv
1 Scope.....	1
2 Normative references.....	1
3 Terms and definitions.....	1
4 Dimensions.....	1
5 Material.....	5
6 Designation.....	5
Bibliography.....	7

iTeh STANDARD PREVIEW (standards.iteh.ai)

ISO 9182-3:2023

<https://standards.iteh.ai/catalog/standards/sist/f89d5ee5-f382-4bf1-acec-0df7af6b6f14/iso-9182-3-2023>

Foreword

ISO (the International Organization for Standardization) is a worldwide federation of national standards bodies (ISO member bodies). The work of preparing International Standards is normally carried out through ISO technical committees. Each member body interested in a subject for which a technical committee has been established has the right to be represented on that committee. International organizations, governmental and non-governmental, in liaison with ISO, also take part in the work. ISO collaborates closely with the International Electrotechnical Commission (IEC) on all matters of electrotechnical standardization.

The procedures used to develop this document and those intended for its further maintenance are described in the ISO/IEC Directives, Part 1. In particular, the different approval criteria needed for the different types of ISO document should be noted. This document was drafted in accordance with the editorial rules of the ISO/IEC Directives, Part 2 (see www.iso.org/directives).

ISO draws attention to the possibility that the implementation of this document may involve the use of (a) patent(s). ISO takes no position concerning the evidence, validity or applicability of any claimed patent rights in respect thereof. As of the date of publication of this document, ISO had not received notice of (a) patent(s) which may be required to implement this document. However, implementers are cautioned that this may not represent the latest information, which may be obtained from the patent database available at www.iso.org/patents. ISO shall not be held responsible for identifying any or all such patent rights.

Any trade name used in this document is information given for the convenience of users and does not constitute an endorsement.

For an explanation of the voluntary nature of standards, the meaning of ISO specific terms and expressions related to conformity assessment, as well as information about ISO's adherence to the World Trade Organization (WTO) principles in the Technical Barriers to Trade (TBT), see www.iso.org/iso/foreword.html.

This document was prepared by Technical Committee ISO/TC 29, *Small tools*, Subcommittee SC 8, *Tools for pressing and moulding*.

This fourth edition cancels and replaces the third edition (ISO 9182-3:2020) which has been technically revised.

The main changes are as follows:

- complete modification of types B1 and B2;
- modification of the hardness of the pillar.

A list of all parts in the ISO 9182 series can be found on the ISO website.

Any feedback or questions on this document should be directed to the user's national standards body. A complete listing of these bodies can be found at www.iso.org/members.html.

Tools for pressing — Guide pillars —

Part 3: Type B, end-locking pillars

1 Scope

This document specifies the dimensions and tolerances of guide pillars, type B, intended for use in press tools.

This document gives guidance on the materials and specifies the hardness and the designation of guide pillars which meet the requirements of this document.

2 Normative references

There are no normative references in this document.

3 Terms and definitions

No terms and definition are listed in this document.

ISO and IEC maintain terminology databases for use in standardization at the following addresses:

— ISO Online browsing platform: available at <https://www.iso.org/obp>

— IEC Electropedia: available at <https://www.electropedia.org/>

4 Dimensions

The dimensions of end-locking guide pillar (type B1) shall conform to the indications of [Figure 1](#) and [Table 1](#).

The dimensions of guide pillars with centre-locking and locking ring (type B2) shall conform to the indications of [Figure 2](#) and [Table 2](#).

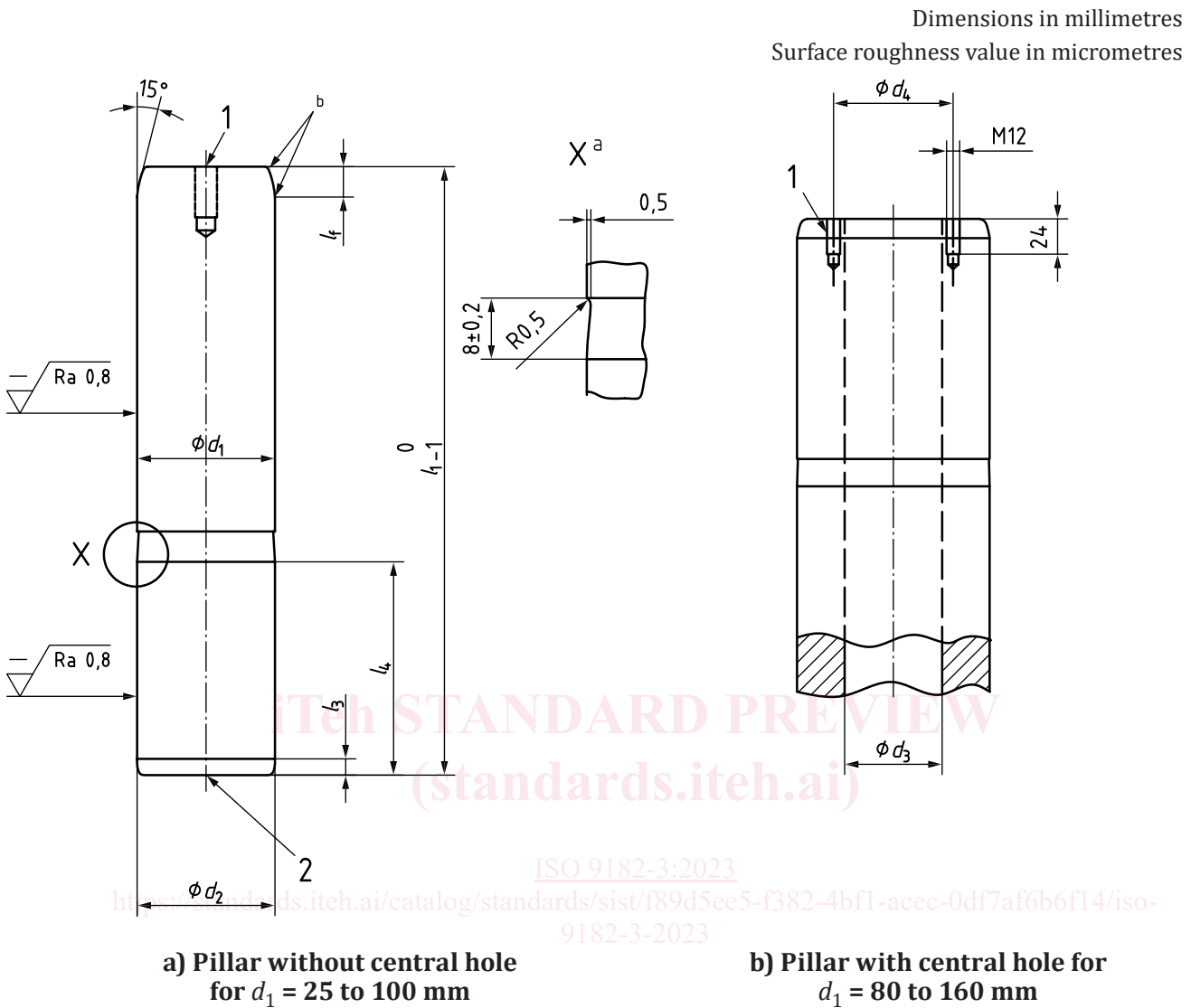

Key

- 1 lifting thread M12 for transporting the pillar for $d_1 = 80$ mm and $d_1 = 100$ mm
- 2 centre hole

NOTE Centre holes are defined in ISO 6411.

- ^a Undercut.
- ^b Slightly rounded. The values of the radii are left to the manufacturer's discretion.

Key

- the1 lifting threads for transporting the pillar

Figure 1 — Type B1, end-locking guide pillar

Table 1 — Dimensions of end-locking guide pillar (type B1)

Dimensions in millimetres

d_1 f6	25	32	40	50	63	80	100	125	160	
d_2 r6	25	32	40	50	63	80	100	125	160	
l_f $\begin{smallmatrix} +0,8 \\ 0 \end{smallmatrix}$	8	8	8	10	10	10	10	12	12	
$d_3 \pm 2$	—	—	—	—	—	40	50	65	95	
d_4 $\begin{smallmatrix} +0,8 \\ 0 \end{smallmatrix}$	—	—	—	—	—	a	72	90	132	
l_3 $\begin{smallmatrix} +0,8 \\ 0 \end{smallmatrix}$	4	4	4	4	4	4	4	5	5	
l_4 $\begin{smallmatrix} +0,8 \\ 0 \end{smallmatrix}$	40	45	56	70	80	100	125	140	180	
l_1	125	(×)								
	140	(×)	(×)	(×)						
	160	×	×	×	×					
	180	(×)	(×)	(×)	(×)	(×)				
	200	×	×	×	×	×	×			
	224	(×)	(×)	(×)	(×)	(×)	(×)	(×)		
	250		×	×	×	×	×	×		
	280			(×)	(×)	(×)	(×)	(×)		
	315				×	×	×	×	×	
	355				×	×	×	×	×	
	400					(×)	×	×	×	(×)
	450						(×)	(×)	×	×
500								×	×	
560									(×)	

Key

× standardized preferred dimension

(×) standardized dimension

NOTE Tolerance classes and limit deviations are defined in ISO 286-2.

a For diameter $d_1 = 80$ no thread when there is a central hole [see Figure 1 b)].

Dimensions in millimetres
Surface roughness value in micrometres

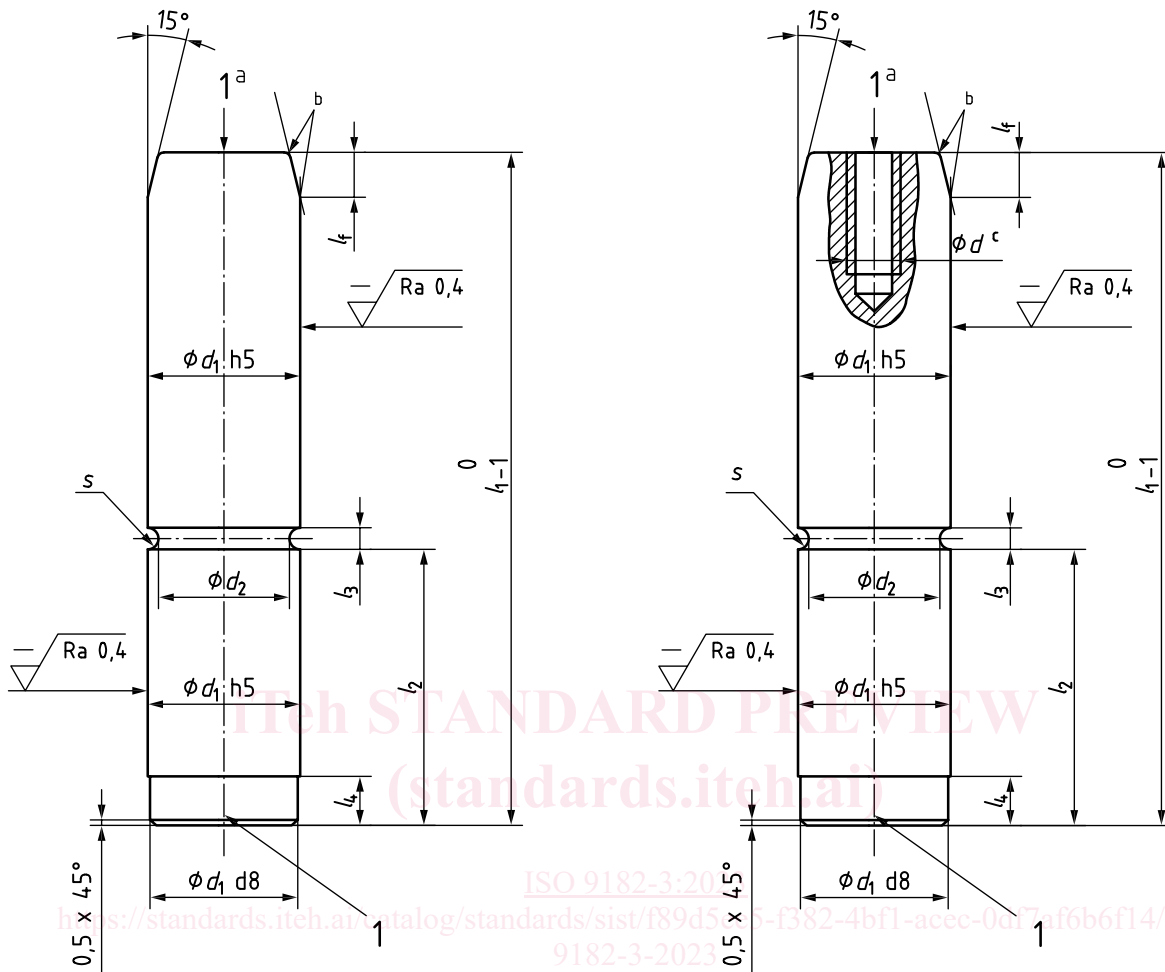

a) Option A without thread

b) Option B with thread

Key

1 centre hole

NOTE Centre holes are defined in ISO 6411.

a Optional.

b Slightly rounded. The values of the radii are left to the manufacturer's discretion.

c The diameter of the thread is left to the manufacturer's discretion.

Figure 2 — Type B2, guide pillars with centre-locking and locking ring

Table 2 — Dimensions of guide pillars with centre locking and locking ring (type B2)

Dimensions in millimetres

d_1	25	32	40	50	63	80	100
$d_2 \begin{smallmatrix} 0 \\ -0,1 \end{smallmatrix}$	22,3	27,8	35,8	45,8	56,8	73,8	93,8
l_f	8	10	12	16	16	16	16
l_2	25	32	63	80	100	125	160
$l_3 \begin{smallmatrix} +0,05 \\ 0 \end{smallmatrix}$	2,7	4,2	4,2	4,2	6,2	6,2	6,2
l_4	8	12	12	12	18	18	18
S	1,35	2,1	2,1	2,1	3,1	3,1	3,1
l_1	125	×					
	140		×				
	160		×				
	180		×	×			
	200		×	×			
	224			×	×		
	250			×	×	×	
	280				×	×	
	315					×	×
	355						×
	400						×
450							×
Key							
× standardized dimension							

<https://standards.iteh.ai/catalog/standards/sist/f89d5ee5-f382-4bf1-acec-0df7af6b6f14/iso-9182-3-2023>

5 Material

The material and hardness are to the manufacturer's discretion, but the hardness shall be $(56 \begin{smallmatrix} +2 \\ 0 \end{smallmatrix})$ HRC.

NOTE Rockwell C hardness (HRC) is defined in ISO 6508-1.

6 Designation

Guide pillars for press tools in accordance with this document shall be designated by:

- “Guide pillar”;
- a reference to this document, i.e. ISO 9182-3:2023;
- its type;
- its diameter, d_1 , in millimetres, and corresponding tolerance;
- its overall length, l_1 , in millimetres;
- option A (for type B1 without central hole or for type B2 without thread) or option B (for type B1 with central hole or for type B2 with thread).

EXAMPLE 1 A guide pillar, type B1, of diameter $d_1 = 25$ mm with a tolerance f6, and overall length $l_1 = 125$ mm with a central hole is designated as follows:

Guide pillar ISO 9182-3 – B1 – 25f6 × 125 – B (option with central hole)

ISO 9182-3:2023(E)

EXAMPLE 2 A guide pillar, type B2, of diameter $d_1 = 25$ mm and overall length $l_1 = 125$ mm with thread is designated as follows:

Guide pillar ISO 9182-3 - B2 - 25 × 125 - B (option with thread)

iTeh STANDARD PREVIEW
(standards.iteh.ai)

ISO 9182-3:2023

<https://standards.iteh.ai/catalog/standards/sist/f89d5ee5-f382-4bf1-acec-0df7af6b6f14/iso-9182-3-2023>