

FINAL  
DRAFT

INTERNATIONAL  
STANDARD

ISO/FDIS  
9557

ISO/TC 8/SC 8

Secretariat: KATS

Voting begins on:  
**2023-10-25**

Voting terminates on:  
**2023-12-20**

---

---

## Ships and marine technology — Wire rope lifting platform for inspection

iTeh Standards  
(<https://standards.iteh.ai>)  
Document Preview

[ISO/FDIS 9557](#)

<https://standards.iteh.ai/catalog/standards/sist/3ba63132-c2f4-4546-b4cb-cda81b9e8ac2/iso-fdis-9557>

RECIPIENTS OF THIS DRAFT ARE INVITED TO SUBMIT, WITH THEIR COMMENTS, NOTIFICATION OF ANY RELEVANT PATENT RIGHTS OF WHICH THEY ARE AWARE AND TO PROVIDE SUPPORTING DOCUMENTATION.

IN ADDITION TO THEIR EVALUATION AS BEING ACCEPTABLE FOR INDUSTRIAL, TECHNOLOGICAL, COMMERCIAL AND USER PURPOSES, DRAFT INTERNATIONAL STANDARDS MAY ON OCCASION HAVE TO BE CONSIDERED IN THE LIGHT OF THEIR POTENTIAL TO BECOME STANDARDS TO WHICH REFERENCE MAY BE MADE IN NATIONAL REGULATIONS.



Reference number  
ISO/FDIS 9557:2023(E)

© ISO 2023

iTeh Standards  
(<https://standards.iteh.ai>)  
Document Preview

[ISO/FDIS 9557](#)

<https://standards.iteh.ai/catalog/standards/sist/3ba63132-c2f4-4546-b4cb-cda81b9e8ac2/iso-fdis-9557>



**COPYRIGHT PROTECTED DOCUMENT**

© ISO 2023

All rights reserved. Unless otherwise specified, or required in the context of its implementation, no part of this publication may be reproduced or utilized otherwise in any form or by any means, electronic or mechanical, including photocopying, or posting on the internet or an intranet, without prior written permission. Permission can be requested from either ISO at the address below or ISO's member body in the country of the requester.

ISO copyright office  
CP 401 • Ch. de Blandonnet 8  
CH-1214 Vernier, Geneva  
Phone: +41 22 749 01 11  
Email: [copyright@iso.org](mailto:copyright@iso.org)  
Website: [www.iso.org](http://www.iso.org)

Published in Switzerland

# Contents

	Page
Foreword.....	iv
<b>1 Scope</b> .....	<b>1</b>
<b>2 Normative references</b> .....	<b>1</b>
<b>3 Terms and definitions</b> .....	<b>1</b>
<b>4 Classification</b> .....	<b>2</b>
4.1 Drive type.....	2
4.2 Rated working load.....	2
<b>5 Design requirements</b> .....	<b>2</b>
5.1 General requirements.....	2
5.2 Safety requirements.....	3
5.3 Main platform structure.....	3
5.4 Hoisting device.....	3
5.5 Fastening device.....	4
5.6 Fall arrest device.....	4
<b>6 Test methods</b> .....	<b>4</b>
6.1 Prototype test.....	4
6.2 Operation under no load.....	4
6.3 Operation under rated load.....	4
6.4 Brake performance test.....	4
6.4.1 Slippage measurement.....	4
6.4.2 Emergency stop test.....	4
6.4.3 Emergency lowering test.....	5
<b>7 Designation</b> .....	<b>5</b>
<b>8 Documentation</b> .....	<b>5</b>
<b>Bibliography</b> .....	<b>6</b>

[ISO/FDIS 9557](https://standards.iteh.ai/catalog/standards/sist/3ba63132-c2f4-4546-b4cb-cda81b9e8ac2/iso-fdis-9557)

<https://standards.iteh.ai/catalog/standards/sist/3ba63132-c2f4-4546-b4cb-cda81b9e8ac2/iso-fdis-9557>

## Foreword

ISO (the International Organization for Standardization) is a worldwide federation of national standards bodies (ISO member bodies). The work of preparing International Standards is normally carried out through ISO technical committees. Each member body interested in a subject for which a technical committee has been established has the right to be represented on that committee. International organizations, governmental and non-governmental, in liaison with ISO, also take part in the work. ISO collaborates closely with the International Electrotechnical Commission (IEC) on all matters of electrotechnical standardization.

The procedures used to develop this document and those intended for its further maintenance are described in the ISO/IEC Directives, Part 1. In particular, the different approval criteria needed for the different types of ISO document should be noted. This document was drafted in accordance with the editorial rules of the ISO/IEC Directives, Part 2 (see [www.iso.org/directives](http://www.iso.org/directives)).

ISO draws attention to the possibility that the implementation of this document may involve the use of (a) patent(s). ISO takes no position concerning the evidence, validity or applicability of any claimed patent rights in respect thereof. As of the date of publication of this document, ISO had not received notice of (a) patent(s) which may be required to implement this document. However, implementers are cautioned that this may not represent the latest information, which may be obtained from the patent database available at [www.iso.org/patents](http://www.iso.org/patents). ISO shall not be held responsible for identifying any or all such patent rights.

Any trade name used in this document is information given for the convenience of users and does not constitute an endorsement.

For an explanation of the voluntary nature of standards, the meaning of ISO specific terms and expressions related to conformity assessment, as well as information about ISO's adherence to the World Trade Organization (WTO) principles in the Technical Barriers to Trade (TBT), see [www.iso.org/iso/foreword.html](http://www.iso.org/iso/foreword.html).

This document was prepared by Technical Committee ISO/TC 8, *Ships and marine technology*, Subcommittee SC 8, *Ship design*.

Any feedback or questions on this document should be directed to the user's national standards body. A complete listing of these bodies can be found at [www.iso.org/members.html](http://www.iso.org/members.html).

# Ships and marine technology — Wire rope lifting platform for inspection

## 1 Scope

This document specifies the classification, design requirements and test methods of wire rope lifting platform for inspection (hereinafter called as “wire lift platform” throughout this document) as an alternative means of access for close-up inspections of under-deck structures of ships and offshore structures.

## 2 Normative references

There are no normative references in this document.

## 3 Terms and definitions

For the purposes of this document, the following terms and definitions apply.

ISO and IEC maintain terminology databases for use in standardization at the following addresses:

- ISO Online browsing platform: available at <https://www.iso.org/obp>
- IEC Electropedia: available at <https://www.electropedia.org/>

### 3.1

#### **alternative means of access**

portable or movable means of access provided for inspections and thickness measurements of hull structures in areas otherwise not accessible by permanent means of access

Note 1 to entry: Areas not accessible by permanent means of access are included in IMO Resolution MSC 158(78).

### 3.2

#### **rated working load**

maximum effective load of the wire lift platform

### 3.3

#### **main platform structure**

device surrounded by guard rails for holding the operators

### 3.4

#### **hoisting device**

device used for lifting and lowering the platform

### 3.5

#### **fastening device**

mechanism fastened to the underdeck structure for hanging platforms and fall arrest devices

### 3.6

#### **fall arrest device**

device connected to operators' safety belts that automatically lock to prevent operators from falling when the platform's falling speed exceeds the set speed

Note 1 to entry: See [Figure 1](#).

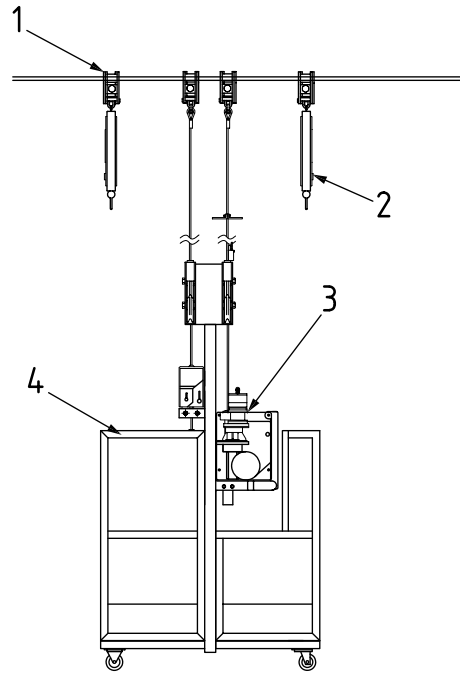

- Key**
- |   |                    |   |                         |
|---|--------------------|---|-------------------------|
| 1 | fastening device   | 3 | hoisting device         |
| 2 | fall arrest device | 4 | main platform structure |

**Figure 1 — Diagram for a wire lift platform**

## 4 Classification

### 4.1 Drive type

The wire lift platform has several types of power sources such as manual, pneumatic and electrical power.

### 4.2 Rated working load

The wire lift platform should be set to the rated working load of 240 kg for two persons.

## 5 Design requirements

### 5.1 General requirements

**5.1.1** Wire lift platform shall be manufactured in accordance with drawings and technical documents approved by the Administration or authorized organizations.

**5.1.2** The self-made parts of wire lift platform shall be assembled after passing the inspection; the standard parts, purchased parts and out-sourced parts shall be assembled only after obtaining the certificate of the manufacturer or passing the inspection specified by the relevant standards.

**5.1.3** The parts of the same model produced by the manufacturer shall be interchangeable.

**5.1.4** The manufacturer shall provide users with relevant information on the installation, operation and maintenance of wire lift platform.