

---

# INTERNATIONAL STANDARD



# 3170

---

INTERNATIONAL ORGANIZATION FOR STANDARDIZATION • МЕЖДУНАРОДНАЯ ОРГАНИЗАЦИЯ ПО СТАНДАРТИЗАЦИИ • ORGANISATION INTERNATIONALE DE NORMALISATION

---

## Petroleum products — Liquid hydrocarbons — Manual sampling

*Produits pétroliers — Hydrocarbures liquides — Échantillonnage manuel*

First edition — 1975-07-01

**ITeH STANDARD PREVIEW**  
**(standards.iteh.ai)**

ISO 3170:1975

<https://standards.iteh.ai/catalog/standards/sist/e74b2879-f955-43e9-b57e-9527585d6c2c/iso-3170-1975>

---

UDC 662.75 : 543.053

Ref. No. ISO 3170-1975 (E)

**Descriptors :** petroleum products, hydrocarbons, liquid fuels, crude oil, sampling, quality control.

## FOREWORD

ISO (the International Organization for Standardization) is a worldwide federation of national standards institutes (ISO Member Bodies). The work of developing International Standards is carried out through ISO Technical Committees. Every Member Body interested in a subject for which a Technical Committee has been set up has the right to be represented on that Committee. International organizations, governmental and non-governmental, in liaison with ISO, also take part in the work.

Draft International Standards adopted by the Technical Committees are circulated to the Member Bodies for approval before their acceptance as International Standards by the ISO Council.

International Standard ISO 3170 was drawn up by Technical Committee ISO/TC 28, *Petroleum products*, and circulated to the Member Bodies in April 1973.

STANDARD PREVIEW  
(standards.iteh.ai)

It has been approved by the Member Bodies of the following countries :

ISO 3170:1975

Australia	Iran	Portugal
Belgium	Israel	Romania
Bulgaria	Japan	South Africa, Rep. of
Canada	Mexico	Sweden
Czechoslovakia	Netherlands	Thailand
Egypt, Arab Rep. of	New Zealand	Turkey
France	Norway	United Kingdom
Germany	Pakistan	U.S.A.
Hungary	Poland	U.S.S.R.

No Member Body expressed disapproval of the document.

# Petroleum products — Liquid hydrocarbons — Manual sampling

## 1 SCOPE AND FIELD OF APPLICATION

1.1 This International Standard specifies the procedures to be used for obtaining samples of materials in liquid state, from fixed tanks, railcars, road vehicles, ships, barges, drums and cans, or from liquids being pumped in pipelines. For the latter, also refer to ISO 3171, *Petroleum products — Liquid hydrocarbons — Automatic pipeline sampling*.

1.2 This International Standard is intended to apply for sampling finished products, also crude oils and intermediate products, which are stored or transported in tanks at or near atmospheric pressure and are handled as liquids at temperatures from near ambient up to 100 °C.

1.3 The samples taken by the procedures given in this International Standard are intended to be used to determine :

- a) quality;
- b) whether contaminants are present;
- c) degree of homogeneity of a batch.

The information obtained may be used for either qualitative or quantitative assessment of the batch being sampled.

1.4 The apparatus used, and the procedures and precautions listed, are those which can be employed for normal petroleum products and crude oils.

1.5 When a batch of materials is to be received or consigned, there are often the alternative possibilities of sampling from a tank, or from a pipeline during the transfer operation.

Pipeline sampling, manual or automatic, as distinct from tank sampling, is generally employed for the following conditions :

- a) when the contents of a tank are likely to suffer from a marked lack of homogeneity, including the presence of two phases with differing densities;
- b) when monitoring material that is being pumped through a pipeline;
- c) for monitoring the performance of in-line blending systems, and for determining the properties of a batch of product being made with an in-line blending system.

It is often necessary to employ both tank and pipeline sampling covering particular operations.

1.6 Pipeline sampling may be manual or automatic. Automatic procedures should be employed if there is a possibility that the liquid flowing through the pipeline is non-homogeneous.

1.7 It is not intended to refer to the sampling of specialized products or to those sampling precautions which are required in relation to particular test methods. These details are either the subjects of individual International Standards or are included in the test methods.

## 2 DEFINITIONS

### 2.1 Samples taken to determine average properties

2.1.1 **upper sample** : A sample taken at a level of one-sixth of the depth of liquid below the top surface.

2.1.2 **middle sample** : A sample taken at a level of one-half of the depth of liquid below the top surface.

2.1.3 **lower sample** : A sample taken at a level of five-sixths of the depth of liquid below the top surface.

2.1.4 **representative sample** : A sample obtained from material in a tank or other receptacle, or consigned as a batch by pipeline, and which has the same composition as the bulk of material from which it is taken, the bulk being considered as a homogeneous whole.

2.1.5 **blend sample** : A sample taken from any suitable point in a tank, or from a tank-side sample connection after mixing the tank contents, and before any significant separation of phases has taken place.

2.1.6 **composite sample** : A sample taken by combining representative samples from a number of tanks or containers in amounts proportional to the contents of each of the tanks or containers.

2.1.7 **continuous sample** : A pipeline sample which is taken continuously during the period of a pumping operation.

**2.1.8 intermittent sample :** A pipeline sample made by combining a series of samples taken throughout the period of a pumping operation.

## 2.2 Samples taken to determine spot properties

**2.2.1 spot sample :** A sample taken at a specific location in a tank, or from a pipeline at a specific time during a pumping operation. It is representative of its own immediate or local environment.

**2.2.2 top sample :** A spot sample obtained 150 mm below the top surface of the liquid.

**2.2.3 bottom sample :** A spot sample taken from the material at the bottom of the tank, or in a pipeline at a low point.

**2.2.4 drain sample :** A spot sample taken from a drain cock or valve.

**2.2.5 outlet sample :** A spot sample taken at the level of the tank outlet (either fixed or swing pipe outlet).

**2.2.6 tank-side sample :** A spot sample taken from a suitable sample connection to the side of a tank.

**2.2.7 surface sample :** A spot sample skimmed from the surface of a liquid in a tank.

**2.3 sample container :** Receptacle used for storage and transport of the sample.

**2.4 sample receiver :** Receptacle normally connected to a sampling draw off connection, or pipeline probe, used to receive the sample. When disconnected it may be used as a sample container.

**2.5 sampling apparatus :** Equipment either portable or fixed used for obtaining a sample.

**2.6 isokinetic sample :** A sample taken from a probe in which the linear velocity of fluid through the opening of the sample probe is equal to the linear velocity in the pipeline and is in the same direction as the bulk of the fluid in the pipeline approaching the probe.

**2.7 flow proportional sample :** A sample taken from a pipeline during the whole period of transfer of a batch, at a rate which is proportional to the rate of flow of the liquid in the pipeline at any instant.

**2.8 time proportional sample :** A sample composed of equal increments taken from a pipeline at regular intervals during the whole period of transfer of a batch through the pipeline.

**2.9 turbulent flow :** Fluid flow in which the particle motion at any point varies rapidly in magnitude and direction. Turbulent flow occurs in a pipeline when the Reynolds number ( $Re$ ) is well above 2 000.

## 3 PRINCIPLE

**3.1** Samples submitted for examination must be representative of the product being sampled. There are numerous precautions necessary to ensure this, depending on the characteristics of the liquid, the tank or pipeline from which the sample is being obtained, and the nature of the tests to be carried out on the sample.

**3.2** To obtain a representative sample from a tank in which the contents are static it is normal to take an upper, middle and lower sample and mix these in a prescribed manner to prepare a single combined sample. Depending on whether the contents are well mixed, the quantity of material contained in the tank, etc., it may be acceptable to take fewer than three samples, or it may be necessary to take more than three samples, to obtain a representative composite sample.

It is normal practice to take three samples from a tank. When the contents of a tank are substantially homogeneous, as shown by preliminary examination of the upper, lower and middle samples, and the cross-section of the vessel is uniform, a representative sample from a tank is usually made up by combining equal parts of samples from levels at one-sixth, one-half and five-sixths of the depth from the top surface of the liquid to the bottom of the tank.

**3.3** When a batch consigned by pipeline is known to be homogeneous, as, for example, when it is being pumped from a tank the contents of which are known to be homogeneous, a representative sample may be obtained by drawing a number of samples from the pipeline at intervals during the pumping and combining these in equal parts.

**3.4** To obtain a representative sample from a batch of material being pumped in a pipeline, the sample must be taken intermittently, or continuously, during the whole period of pumping. The sample should be taken by means of a suitable sample probe, preferably in an isokinetic manner from an area of turbulent flow, at a location a sufficient distance downstream of the last point of injection of any component to ensure that all such components are adequately mixed (see 4.6).

**3.5** This International Standard also covers procedures intended to verify a lack of homogeneity, or presence of two phases or of contaminants in a liquid in a vessel or pipeline, by taking appropriate spot samples.

## 4 APPARATUS

### 4.1 Containers

Sample containers are receptacles used for the storage and transport of samples, and shall have a suitable cap, stopper, lid or valve. The size normally varies between 0,25 and 5 l, but larger containers may be required when special tests, bulking, or division of samples, etc., are called for.

The container used must be impervious to, and resistant to solvent action by, the product handled. It must be of sufficient strength to withstand normal internal pressures likely to be generated, and sufficiently robust to withstand normal handling.

#### 4.1.1 Glass bottles

**4.1.1.1** Glass bottles shall be provided with a cork, a glass stopper or a plastics or metal screw-cap fitted with an oil-resistant disc. Corks shall not be used for volatile liquids. If the product is sensitive to light, the sample bottle shall be dark coloured.

**4.1.1.2** Glass bottles and their closures shall be clean and dry. The method of cleaning will depend upon the condition, or previous contents, of the bottle, the nature of the sample, and the tests to be carried out.

**4.1.1.3** Glass bottles shall not be used for materials with a Reid vapour pressure greater than 1,8 bar. If the vapour pressure of the product to be sampled is between 1,0 and 1,8 bar, the bottle shall be protected with a metal case until the sample is discarded.

#### 4.1.2 Cans

These shall be made of suitable tinplate and should have pressed seams or seams soldered on the exterior surfaces using a flux of resin in a suitable solvent. Cans may be closed by means of screw-caps with oil-resistant discs, which shall be discarded after being used once. Corks shall not be used. Cans and their closures shall be clean and dry. The method of cleaning will depend on the condition, or previous contents, of the can, the nature of the sample and the tests to be carried out. Cans should be inspected before use and rejected if leaks or rust are present.

#### 4.1.3 Plastics bottles

Plastics bottles made of suitable unpigmented linear polyethylene with a minimum density of 0,950 g/cm<sup>3</sup>, and with a minimum wall thickness of 0,7 mm may be used for the handling and storage of gas oil, diesel oil, fuel oil and lubricating oil. They should not be used for gasoline, aviation jet fuel (avtur), kerosine, crude-oil, white spirit, medicinal white oil and special boiling point products.

NOTE — In no circumstances shall non-linear (conventional) polyethylene containers be used to store samples of liquid hydrocarbons.

Used engine-oil samples which may have been subjected to fuel dilution should not be stored in plastics containers.

NOTE — Plastics bottles have the advantage that they will not shatter like glass or corrode like metal containers. They are generally used only once and then discarded so that re-cleaning and recovery procedures are not required.

#### 4.1.4 Weighted sampling can

This should be of suitable capacity, for example 0,5 to 1 l, and of such a weight as to sink readily in the material to be sampled. The can shall have a cord or a chain of spark-proof material attached and shall be provided with means to permit filling at any desired level in the tank. The metal used to weight the apparatus shall be fitted externally or be contained in an oil-tight false bottom, since irregularities in the metal may retain material which will contaminate the sample if the weight is fitted to the interior. Figure 1 shows examples of suitable equipment.

### 4.2 Sampling cage

This shall be a metal or plastics holder or cage, suitably constructed to hold the appropriate container. The combined apparatus shall be of such a weight as to sink readily in the material to be sampled, and provision shall be made to fill the container at any desired level (see figures 2 and 3).

Bottles of special dimensions are required to fit a sampling cage. The use of a sampling cage is generally preferred to that of a weighted sampling can, for clean volatile products, since loss of light ends is likely to occur when transferring the sample from a weighted sampling can to another container.

### 4.3 Stoppers and closures

Corks, ground glass stoppers, or plastics or metal screw-caps may be used for closing sample bottles. Rubber stoppers shall not be used. Corks shall be of good quality and free from loose pieces or dust. They should be softened by rolling or squeezing and pressed well into the neck of the bottle to prevent leakage or evaporation. Where necessary a protective cover of a suitable material may be used. Corks shall not be used with volatile liquids, as the vapour may penetrate into the cork and cause contamination of subsequent samples.

Screw-caps of cans or bottles shall be fitted with discs of cork or other oil-resistant material. The disc, which shall only be used once, shall be removed before the cleaning of screw-caps and a new disc shall subsequently be fitted. Corks and stoppers shall be tied or wired on or covered with a paper cap tied round the neck of the bottle, or sealed with a viscose cap. Sealing wax or paraffin wax shall NOT be used.

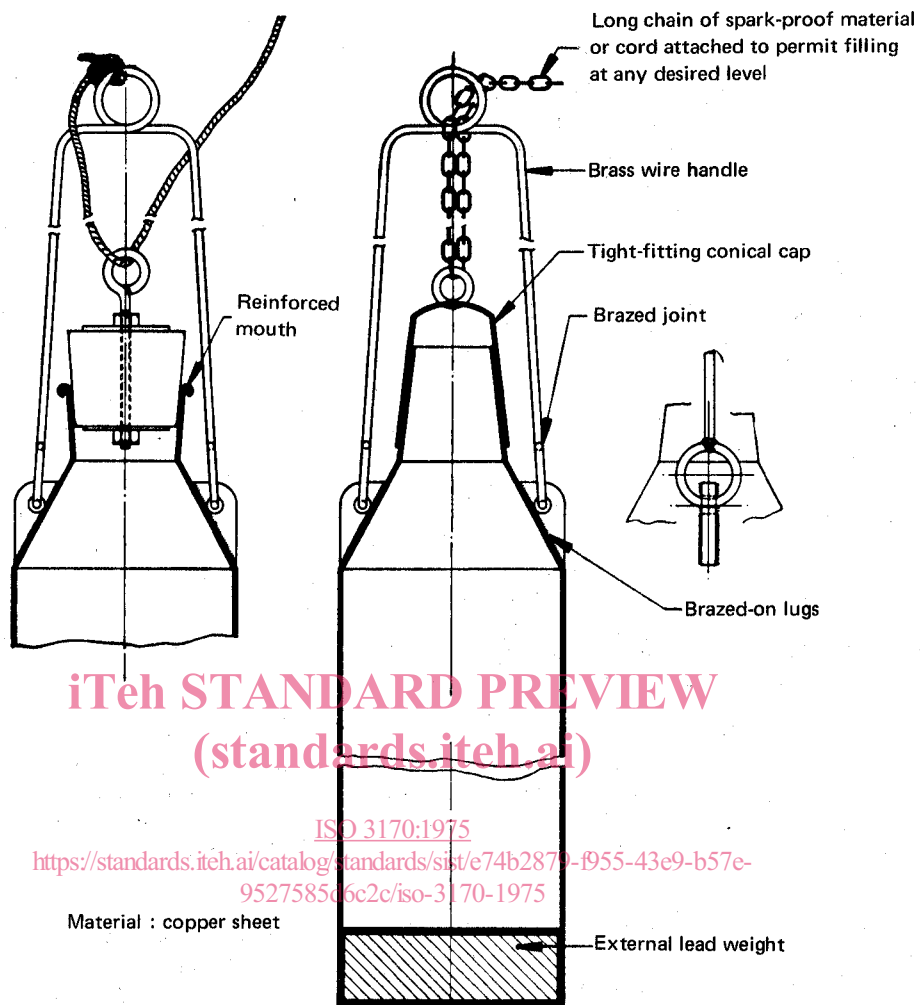

iTeh STANDARD PREVIEW  
(standards.iteh.ai)

ISO 3170:1975

<https://standards.iteh.ai/catalog/standards/sist/e74b2879-f955-43e9-b57e-9527585d6c2c/iso-3170-1975>

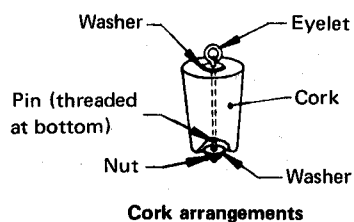
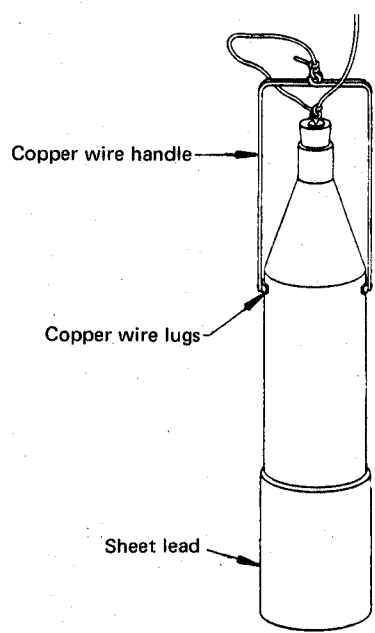

FIGURE 1 — Examples of weighted sampling cans

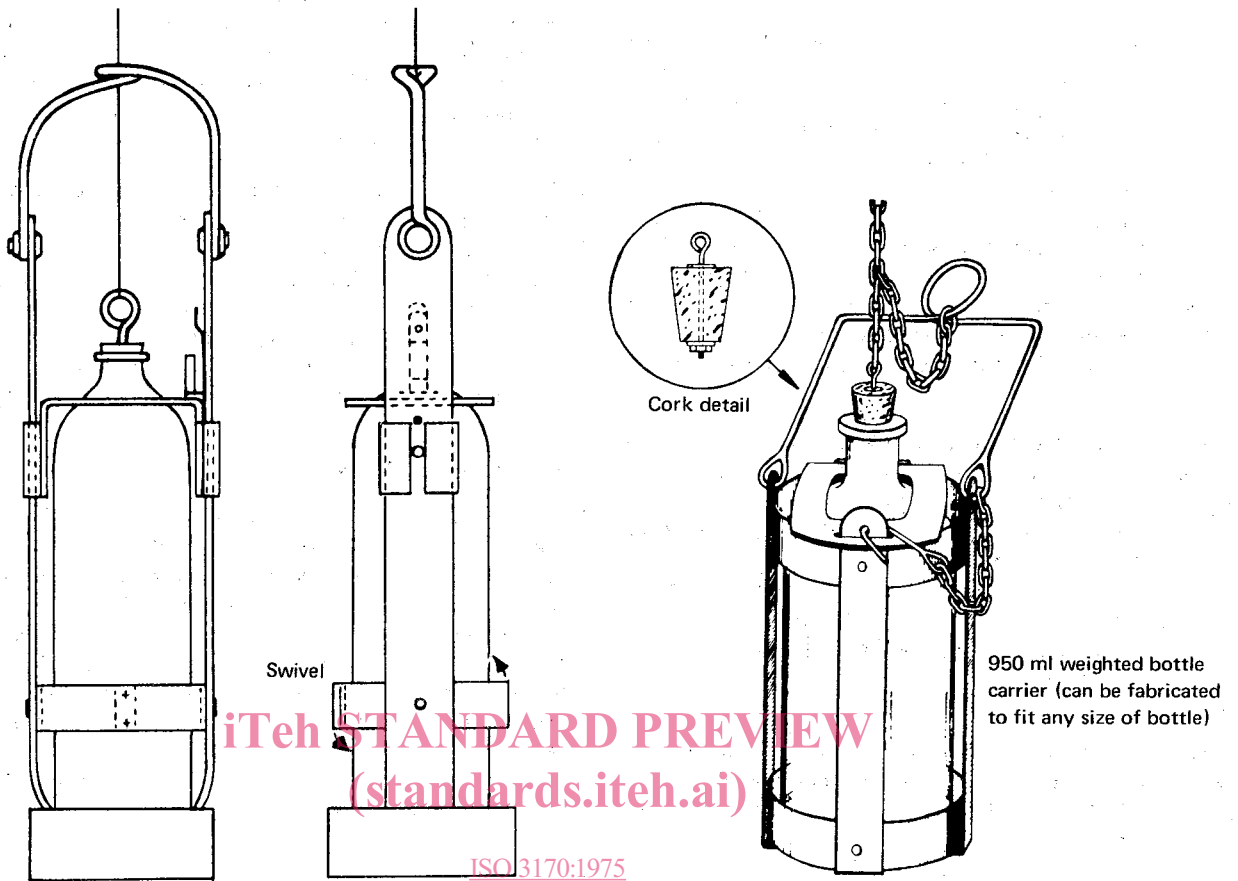

FIGURE 2 — Examples of sample cages

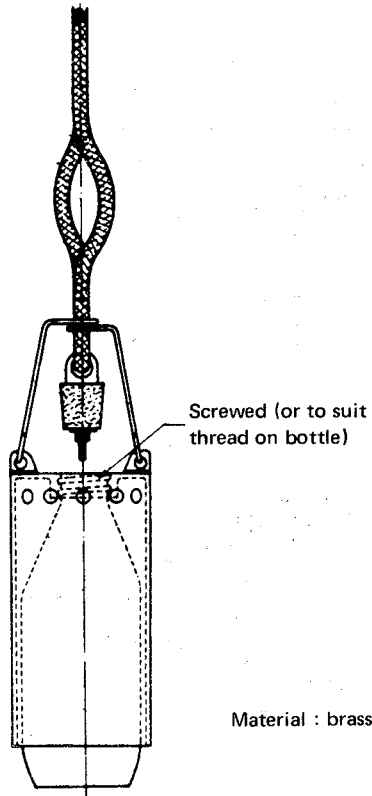

FIGURE 3 — Example of sampling cage for use with screw-top glass 600 ml sample bottle

#### 4.4 Slot dipper

This is intended for drawing samples from fixed roof tanks operating up to about 55 mbar gauge pressure in order to minimize loss of vapour from the tank. An example is shown in figure 4 and consists essentially of a flanged aluminium stand pipe with a flap valve in the lower portion of the body and a hinged cover at the top. The counterweight of the flap shall be adjusted so that the valve can be held in the closed position with a filled sampling cage resting upon it. A special sampling cord shall be supplied with the apparatus, providing a close sliding fit in an adaptor which can be fastened to the top cover. This adaptor shall normally be kept permanently attached to the cord.

A sampling cage as described in 4.2 is required. Sampling operations are facilitated if the cage is fitted with a short operating cord permanently fastened to the cork, passed through the loop of the case, and terminated in a loop or ring. The main sampling cord should be fitted with a clip for attachment to this loop or ring. The operating portion of the cord shall be as short as possible so that when the cage is filled and suspended by the sampling cord within the slot dipper, the flap valve can be closed without fouling the cage.

To use the slot dipper, thread the main sampling cord through the sample cord adaptor. Ensure that the lower flap valve is in the closed position, remove the plug in the

top cover, open the cover, and fasten the sample cord adaptor to the bayonet fitting in the cover. Fasten the clip on the sampling cord to the operating cord on the sampling cage, close the bottle with its cork, and insert the cage into the dipping device. It may be rested on the closed flap valve. Close and securely fasten the top cover.

Take the weight of the sampling cage on the cord, open the lower flap valve and lower the apparatus to the required depth. Jerk out the cork, allow the sampling apparatus to fill, and haul it up into the slot dipper. Close the flap valve and rest the sampling apparatus upon it. Open the top cover and remove the sampling cage. Pour off sufficient liquid to create 5 to 10% ullage and stopper the container immediately. Close the top cover and replace the plug.

#### 4.5 Vapour-lock device

This is an alternative to the slot dipper, and is normally used for operating pressures up to 700 mbar gauge. It shall consist of a gas-tight enclosure placed on top of a valved roof connection as shown in figure 5 a). A sample container in a suitable sampling cage, or the special sampler shown in figure 5 b), can be attached, via a gas-tight window, to the lowering gear. The window is then closed, the roof valve opened, and the sample container or sampler lowered to the required depth of the product before filling. The valve is closed with the sampler in the elevated position before the latter is withdrawn via the window.

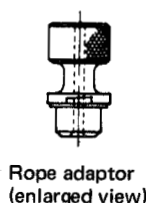
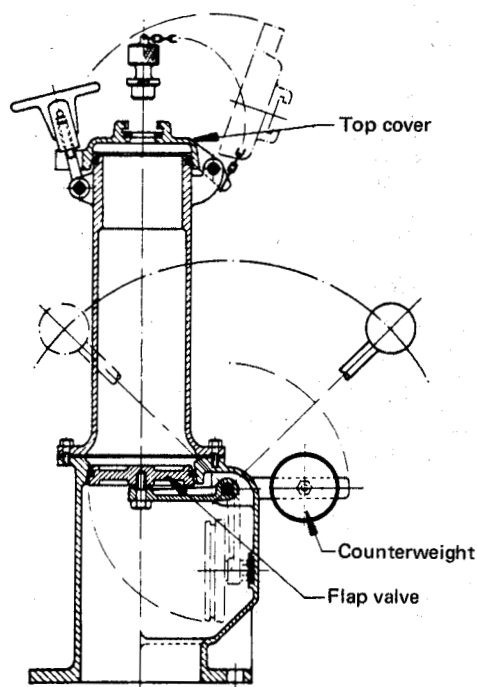
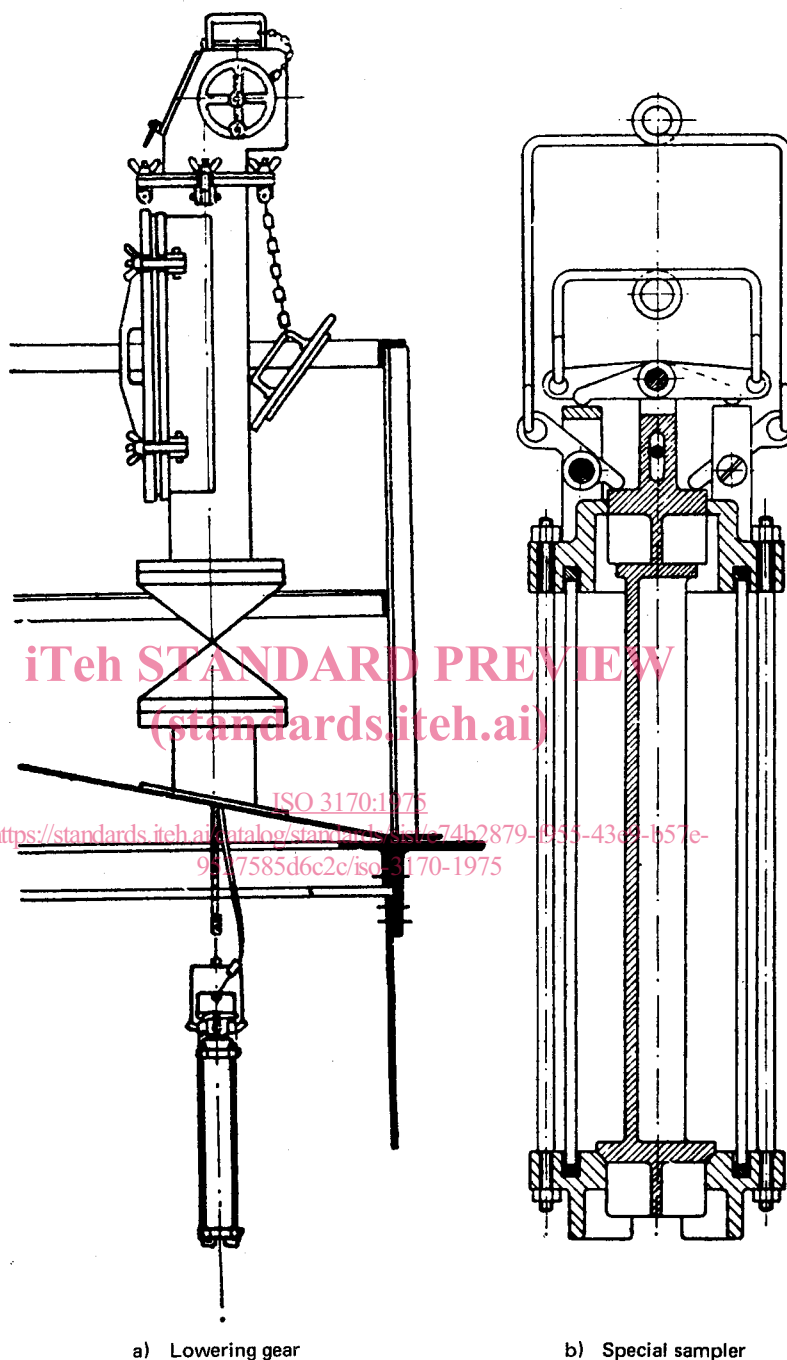

FIGURE 4 – Example of slot dipper





iTeh STANDARD PREVIEW  
 (standards.iteh.ai)

ISO 3170:1975  
<https://standards.iteh.ai/catalog/standards/iso/3170-1975-9917585d6c2c/iso-3170-1975>

a) Lowering gear

b) Special sampler

FIGURE 5 — Example of vapour-lock device