**Measurement of fluid flow by means of
pressure differential devices inserted
in circular cross-section conduits
running full —**

**Part 5:
Cone meters**

*Mesurage de débit des fluides au moyen d'appareils déprimogènes
insérés dans des conduites en charge de section circulaire —*

Partie 5: Cônes de mesure

ISO 5167-5:2022

<https://standards.iteh.ai/catalog/standards/sist/1788bb89-e8f6-4502-806c-491883f7980a/iso-5167-5-2022>



iTeh STANDARD PREVIEW
(standards.iteh.ai)

ISO 5167-5:2022

<https://standards.iteh.ai/catalog/standards/sist/1788bb89-e8f6-4502-806c-491883f7980a/iso-5167-5-2022>



COPYRIGHT PROTECTED DOCUMENT

© ISO 2022

All rights reserved. Unless otherwise specified, or required in the context of its implementation, no part of this publication may be reproduced or utilized otherwise in any form or by any means, electronic or mechanical, including photocopying, or posting on the internet or an intranet, without prior written permission. Permission can be requested from either ISO at the address below or ISO's member body in the country of the requester.

ISO copyright office
CP 401 • Ch. de Blandonnet 8
CH-1214 Vernier, Geneva
Phone: +41 22 749 01 11
Email: copyright@iso.org
Website: www.iso.org

Published in Switzerland

Contents

| | Page |
|---|-----------|
| Foreword..... | iv |
| Introduction..... | v |
| 1 Scope..... | 1 |
| 2 Normative references..... | 1 |
| 3 Terms and definitions..... | 1 |
| 4 Principles of the method of measurement and computation..... | 2 |
| 5 Cone meters..... | 3 |
| 5.1 Field of application..... | 3 |
| 5.2 General shape..... | 3 |
| 5.3 Material and manufacture..... | 7 |
| 5.4 Pressure tappings..... | 8 |
| 5.5 Discharge coefficient, C | 8 |
| 5.5.1 Limits of use..... | 8 |
| 5.5.2 Discharge coefficient of the cone meter..... | 8 |
| 5.6 Expansibility (expansion) factor, ε | 9 |
| 5.7 Uncertainty of the discharge coefficient, C | 9 |
| 5.8 Uncertainty of the expansibility (expansion) factor, ε | 9 |
| 5.9 Pressure loss..... | 9 |
| 6 Installation requirements..... | 10 |
| 6.1 General..... | 10 |
| 6.2 Minimum upstream and downstream straight lengths for installations between various fittings and the cone meter..... | 10 |
| 6.2.1 General..... | 10 |
| 6.2.2 Single 90° bend..... | 11 |
| 6.2.3 Two 90° bends in perpendicular planes..... | 11 |
| 6.2.4 Concentric expander..... | 11 |
| 6.2.5 Partially closed valves..... | 11 |
| 6.3 Additional specific installation requirements for cone meters..... | 11 |
| 6.3.1 Circularity and cylindricality of the pipe..... | 11 |
| 6.3.2 Roughness of the upstream and downstream pipe..... | 11 |
| 6.3.3 Positioning of a thermowell..... | 11 |
| 7 Flow calibration of cone meters..... | 12 |
| 7.1 General..... | 12 |
| 7.2 Test facility..... | 12 |
| 7.3 Meter installation..... | 12 |
| 7.4 Design of the test programme..... | 12 |
| 7.5 Reporting the calibration results..... | 13 |
| 7.6 Uncertainty analysis of the calibration..... | 13 |
| 7.6.1 General..... | 13 |
| 7.6.2 Uncertainty of the test facility..... | 13 |
| 7.6.3 Uncertainty of the discharge coefficient of the cone meter..... | 13 |
| Annex A (informative) Table of expansibility (expansion) factor..... | 14 |
| Bibliography..... | 15 |

Foreword

ISO (the International Organization for Standardization) is a worldwide federation of national standards bodies (ISO member bodies). The work of preparing International Standards is normally carried out through ISO technical committees. Each member body interested in a subject for which a technical committee has been established has the right to be represented on that committee. International organizations, governmental and non-governmental, in liaison with ISO, also take part in the work. ISO collaborates closely with the International Electrotechnical Commission (IEC) on all matters of electrotechnical standardization.

The procedures used to develop this document and those intended for its further maintenance are described in the ISO/IEC Directives, Part 1. In particular the different approval criteria needed for the different types of ISO documents should be noted. This document was drafted in accordance with the editorial rules of the ISO/IEC Directives, Part 2 (see www.iso.org/directives).

Attention is drawn to the possibility that some of the elements of this document may be the subject of patent rights. ISO shall not be held responsible for identifying any or all such patent rights. Details of any patent rights identified during the development of the document will be in the Introduction and/or on the ISO list of patent declarations received (see www.iso.org/patents).

Any trade name used in this document is information given for the convenience of users and does not constitute an endorsement.

For an explanation on the meaning of ISO specific terms and expressions related to conformity assessment, as well as information about ISO's adherence to the WTO principles in the Technical Barriers to Trade (TBT) see the following URL: [Foreword - Supplementary information](#).

The committee responsible for this document is ISO/TC 30, *Measurement of fluid flow in closed conduits*, Subcommittee SC 2, *Pressure differential devices*, in collaboration with the European Committee for Standardization (CEN) Technical Committee CEN/SS F05, *Measuring instruments*, in accordance with the Agreement on technical cooperation between ISO and CEN (Vienna Agreement).

This second edition of ISO 5167-5 cancels and replaces the first edition (ISO 5167-5:2016), which has been technically revised.

The main changes are as follows:

- this document is consistent with ISO/IEC Guide 98-3;
- errors in [Figure 2](#) and in [5.2.7](#) have been corrected;
- the expansibility uncertainty is given as a relative uncertainty for ease of use with ISO 5167-1 (the calculated flow rate uncertainty is unchanged).

A list of all parts in the ISO 5167 series can be found on the ISO website.

Introduction

ISO 5167, consisting of six parts, covers the geometry and method of use (installation and operating conditions) of orifice plates, nozzles, Venturi tubes, cone meters and wedge meters when they are inserted in a conduit running full to determine the flow rate of the fluid in the conduit. It also gives necessary information for calculating the flow rate and its associated uncertainty. ISO 5167 (all parts) also provides methodology for bespoke calibration of differential pressure meters.

ISO 5167 (all parts) is applicable only to pressure differential devices in which the flow remains subsonic throughout the measuring section and where the fluid can be considered as single-phase, but is not applicable to the measurement of pulsating flow. Furthermore, each of these devices can only be used within specified limits of pipe size and Reynolds number, or alternatively they can be used across their calibrated range.

ISO 5167 (all parts) deals with devices for which direct calibration experiments have been made sufficient in number, spread, and quality to enable coherent systems of application to be based on their results and coefficients to be given with certain predictable limits of uncertainty.

The devices introduced into the pipe are called primary devices. The term primary device also includes the pressure tappings. All other instruments or devices required to facilitate the instrument readings are known as secondary devices, and the flow computer that receives these readings and performs the algorithms is known as a tertiary device. ISO 5167 (all parts) covers primary devices; secondary devices (see ISO 2186) and tertiary devices will be mentioned only occasionally.

Aspects of safety are not dealt with in ISO 5167 (all parts). It is the responsibility of the user to ensure that the system meets applicable safety regulations.

(standards.iteh.ai)

[ISO 5167-5:2022](https://standards.iteh.ai/catalog/standards/sist/1788bb89-e8f6-4502-806c-491883f7980a/iso-5167-5-2022)

<https://standards.iteh.ai/catalog/standards/sist/1788bb89-e8f6-4502-806c-491883f7980a/iso-5167-5-2022>

Measurement of fluid flow by means of pressure differential devices inserted in circular cross-section conduits running full —

Part 5: Cone meters

1 Scope

This document specifies the geometry and method of use (installation and operating conditions) of cone meters when they are inserted in a conduit running full to determine the flow rate of the fluid flowing in the conduit.

As the uncertainty of an uncalibrated cone meter might be too high for a particular application, it might be deemed essential to calibrate the flow meter in accordance with [Clause 7](#).

This document also provides background information for calculating the flow rate and is applicable in conjunction with the requirements given in ISO 5167-1.

This document is applicable only to cone meters in which the flow remains subsonic throughout the measuring section and where the fluid can be considered as single-phase. Uncalibrated cone meters can only be used within specified limits of pipe size, roughness, β , and Reynolds number, Re . This document is not applicable to the measurement of pulsating flow. It does not cover the use of uncalibrated cone meters in pipes sized less than 50 mm or more than 500 mm, or where the pipe Reynolds numbers are below 8×10^4 or greater than $1,2 \times 10^7$.

A cone meter is a primary device which consists of a cone-shaped restriction held concentrically in the centre of the pipe with the nose of the cone upstream. The design of cone meter defined in this document has one or more upstream pressure tapings in the wall, and a downstream pressure tapping positioned in the back face of the cone with the connection to a differential pressure transmitter being a hole through the cone to the support bar, and then up through the support bar.

Alternative designs of cone meters are available; however, at the time of writing, there is insufficient data to fully characterize these devices, and therefore, these meters shall be calibrated in accordance with [Clause 7](#).

2 Normative references

The following documents are referred to in the text in such a way that some or all of their content constitutes requirements of this document. For dated references, only the edition cited applies. For undated references, the latest edition of the referenced document (including any amendments) applies.

ISO 4006, *Measurement of fluid flow in closed conduits — Vocabulary and symbols*

ISO 5167-1, *Measurement of fluid flow by means of pressure differential devices inserted in circular cross-section conduits running full — Part 1: General principles and requirements*

3 Terms and definitions

For the purposes of this document, the terms and definitions given in ISO 4006, ISO 5167-1, and the following apply.

ISO and IEC maintain terminology databases for use in standardization at the following addresses:

- ISO Online browsing platform: available at <https://www.iso.org/obp>
- IEC Electropedia: available at <https://www.electropedia.org/>

3.1
beta edge

maximum circumference of the cone

4 Principles of the method of measurement and computation

The principle of the method of measurement is based on the installation of the cone meter into a pipeline in which a fluid is running full. Flow through a cone meter produces a differential pressure between the upstream and downstream tappings.

The mass flow rate can be determined by [Formulae \(1\)](#) and [\(2\)](#):

$$q_m = \frac{C}{\sqrt{1-\beta^4}} \varepsilon \frac{\pi}{4} (D\beta)^2 \sqrt{2\Delta p \rho_1} \tag{1}$$

and

$$\beta = \sqrt{1 - \frac{d_c^2}{D^2}} \tag{2}$$

where d_c is the diameter of the cone in the plane of the beta edge. This assumes that the diameter of the pipe at the upstream tapping, D_{TAP} , is equal to the diameter of the pipe at the beta edge, D . [Figure 1](#) shows that as the cone diameter increases, β decreases.

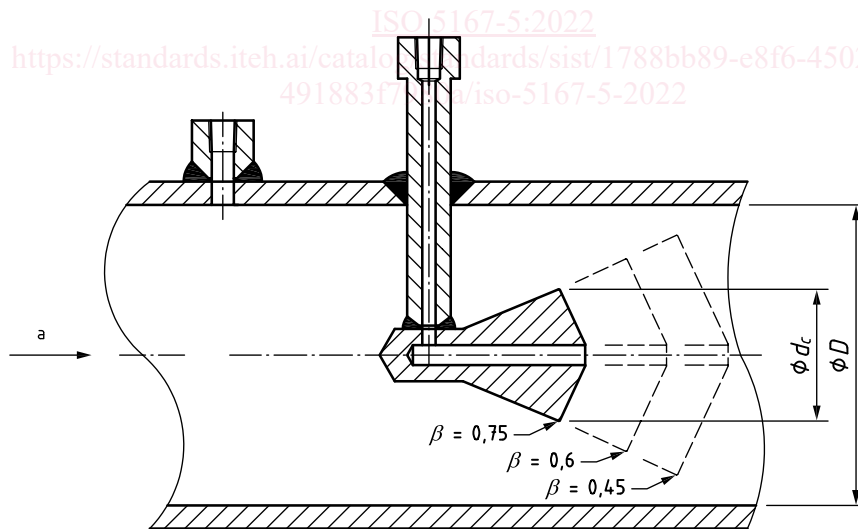

a Direction of flow.

Figure 1 — Cone meter showing different values of β

The uncertainty can be calculated using the procedure given in ISO 5167-1:2022, Clause 8.

Similarly, the value of the volume flow rate can be calculated since

$$q_V = \frac{q_m}{\rho} \quad (3)$$

where ρ is the fluid density at the temperature and pressure for which the volume is stated.

Computation of the flow rate, which is a purely arithmetic process, is performed by replacing the different items on the right-hand side of [Formula \(1\)](#) by their numerical values. [Formula \(4\)](#) in [5.6](#) (or the computed values in [Table A.1](#)) gives cone meter expansibility factors, ε . The values in [Table A.1](#) are not intended for precise interpolation. Extrapolation is not permitted. However, the discharge coefficient, C , is generally dependent on the Reynolds number, Re , which is itself dependent on q_m , and has to be obtained by iteration (see ISO 5167-1:2022, Annex A for guidance regarding the choice of iteration procedure and initial estimates).

The diameters, d_c and D , mentioned in [Formulae \(1\)](#) and [\(2\)](#) are the values of the diameters at working conditions. Measurements taken at any other conditions should be corrected for any possible expansion or contraction of the primary device and the pipe due to the values of the temperature and pressure of the fluid during the measurement.

As the cone meter flow rate calculation is particularly sensitive to the pipe and cone diameter values used, the user shall ensure that these are correctly entered into the flow computation calculations. For example, care shall be taken to use the measured internal diameter rather than a nominal value.

It is necessary to know the density and the viscosity of the fluid at working conditions. In the case of a compressible fluid, it is also necessary to know the isentropic exponent of the fluid at working conditions.

(standards.iteh.ai)

5 Cone meters

5.1 Field of application

Uncalibrated cone meters can be used in pipes with diameters between 50 mm and 500 mm and with $0,45 \leq \beta \leq 0,75$. Cone meters with $\beta > 0,75$ shall be calibrated. Cone meters with values of $\beta < 0,45$ are not normally manufactured.

There are limits to the roughness and Reynolds number which shall be addressed.

5.2 General shape

5.2.1 [Figure 2](#) shows a section through the centreline of a cone meter. [Figure 4](#) shows other sections through the meter to aid in the metrology of the cone meter. The letters used in the text refer to those shown in [Figure 2](#) and [Figure 4](#).

The cone meter is made up of a pipe section of diameter, D , which houses the cone assembly with cone diameter, d_c , the support structure for the cone, and the tappings for differential pressure measurement. The cone assembly is installed such that the cone centreline is concentric to the centreline of the pipe section, as per [5.2.13](#).

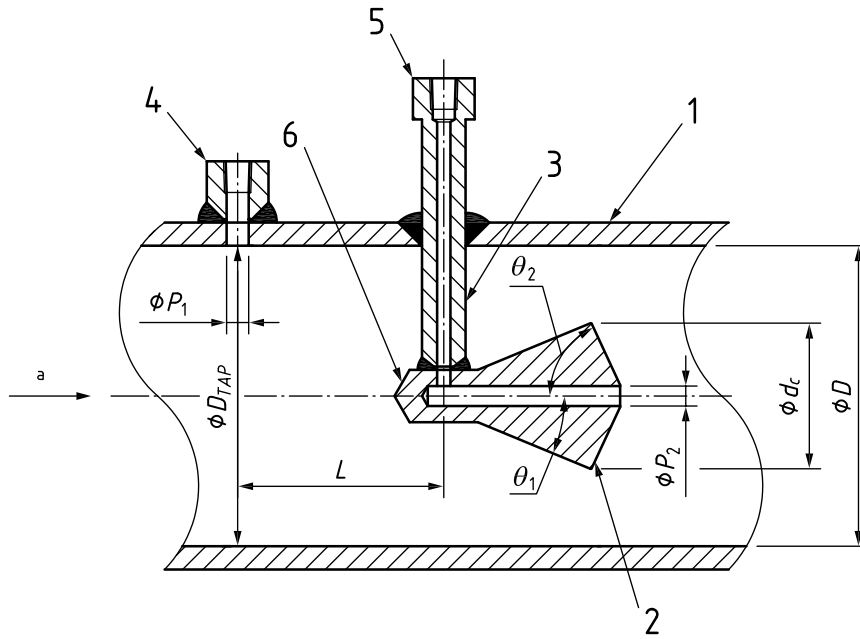

Key

- 1 body pipe
- 2 cone element
- 3 support strut
- 4 high pressure tapping
- 5 low pressure tapping
- 6 cone nose
- a Direction of flow.

iTeh STANDARD PREVIEW
(standards.iteh.ai)

ISO 5167-5:2022

NOTE $50 \text{ mm} \leq L \leq 2D$, as defined in 5.4.7.

Figure 2 — Geometric profile of cone meter

5.2.2 The design of the nose of the cone (for example see Figure 3) can be constructed as a machined component or from an elbow. The nose shall be downstream of the plane of the centreline of the upstream tapping(s). It is recommended that the nose be as short as practicable.

These designs shown in Figure 3 should not be considered exclusive.

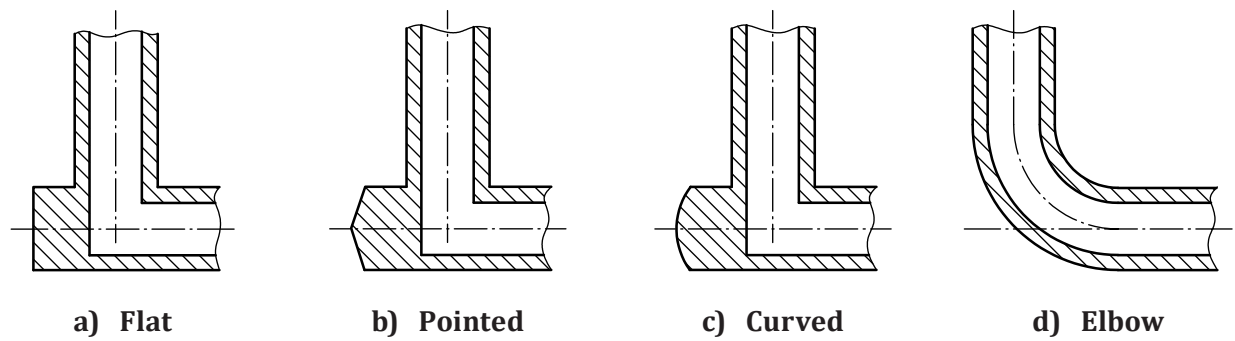

Figure 3 — Examples of different cone nose designs

5.2.3 The pipe diameter, D , shall be measured at plane A of [Figure 4](#). The number of measurements shall be a minimum of four equally spaced around the pipe internal circumference. The arithmetic mean value of these measurements shall be taken as the value of D in the calculations.

5.2.4 The pipe diameter shall also be measured at plane C of [Figure 4](#) (shown as D_{TAP} in [Figure 2](#)). The number of measurements at this plane shall be at least equal to the number of pressure tapplings (with a minimum of four).

5.2.5 No diameter at any point between plane C and $1D$ downstream of plane A from [Figure 4](#) shall differ from the pipe diameter, D , by more than 1,0 %.

(standards.iteh.ai)

ISO 5167-5:2022

<https://standards.iteh.ai/catalog/standards/sist/1788bb89-e8f6-4502-806c-491883f7980a/iso-5167-5-2022>