

ISO/TC 131/SC 5

Secretariat: AFNOR

Voting begins on:
2023-07-19

Voting terminates on:
2023-09-13

Pneumatic fluid power — Compressed air pressure regulators and filter-regulators —

Part 1: Main characteristics to include in supplier's literature and product-marking requirements

Transmissions pneumatiques — Régulateurs de pression et filtres-régulateurs pour air comprimé —

Partie 1: Principales caractéristiques à inclure dans la documentation des fournisseurs et exigences de marquage du produit

RECIPIENTS OF THIS DRAFT ARE INVITED TO SUBMIT, WITH THEIR COMMENTS, NOTIFICATION OF ANY RELEVANT PATENT RIGHTS OF WHICH THEY ARE AWARE AND TO PROVIDE SUPPORTING DOCUMENTATION.

IN ADDITION TO THEIR EVALUATION AS BEING ACCEPTABLE FOR INDUSTRIAL, TECHNOLOGICAL, COMMERCIAL AND USER PURPOSES, DRAFT INTERNATIONAL STANDARDS MAY ON OCCASION HAVE TO BE CONSIDERED IN THE LIGHT OF THEIR POTENTIAL TO BECOME STANDARDS TO WHICH REFERENCE MAY BE MADE IN NATIONAL REGULATIONS.



Reference number
ISO/FDIS 6953-1:2023(E)

© ISO 2023

iTeh STANDARD PREVIEW
(standards.iteh.ai)

ISO 6953-1

<https://standards.iteh.ai/catalog/standards/sist/e8401fb2-a9b8-4a90-89d6-7bccc8c001d9/iso-6953-1>



COPYRIGHT PROTECTED DOCUMENT

© ISO 2023

All rights reserved. Unless otherwise specified, or required in the context of its implementation, no part of this publication may be reproduced or utilized otherwise in any form or by any means, electronic or mechanical, including photocopying, or posting on the internet or an intranet, without prior written permission. Permission can be requested from either ISO at the address below or ISO's member body in the country of the requester.

ISO copyright office
CP 401 • Ch. de Blandonnet 8
CH-1214 Vernier, Geneva
Phone: +41 22 749 01 11
Email: copyright@iso.org
Website: www.iso.org

Published in Switzerland

Contents

	Page
Foreword	iv
Introduction	v
1 Scope	1
2 Normative references	1
3 Terms and definitions	2
4 Technical requirements	3
4.1 General.....	3
4.2 General characteristics.....	3
4.2.1 General dimensions.....	3
4.2.2 Port forms.....	4
4.2.3 Rated pressure.....	4
4.2.4 Range of operating temperatures.....	4
4.3 Particular requirements.....	4
4.3.1 General.....	4
4.3.2 Adjustable pressure ranges (outlet regulated pressure).....	4
4.3.3 Flow rate-pressure characteristics.....	5
4.3.4 Pressure regulation characteristic.....	6
4.3.5 Pilot pressure/regulated pressure characteristics.....	7
4.3.6 Repeatability.....	8
4.3.7 Output resolution in the case of manual air pressure.....	8
4.3.8 Resolution in the case of pressure-pilot air pressure regulator.....	8
4.3.9 Sensitivity for manual and pressure-pilot air pressure regulator.....	8
4.3.10 Maximum air consumption at null forward flow rate or relief flow rate for pilot-operated regulator with air bleed.....	8
4.3.11 Useful retention capacity of the reservoir.....	9
4.3.12 Filter-regulator draining devices.....	9
4.3.13 Materials of construction.....	9
5 Operation and maintenance	9
6 Marking	9
7 Identification statement — Reference to ISO 6953-1 (this document)	10
Bibliography	11

Foreword

ISO (the International Organization for Standardization) is a worldwide federation of national standards bodies (ISO member bodies). The work of preparing International Standards is normally carried out through ISO technical committees. Each member body interested in a subject for which a technical committee has been established has the right to be represented on that committee. International organizations, governmental and non-governmental, in liaison with ISO, also take part in the work. ISO collaborates closely with the International Electrotechnical Commission (IEC) on all matters of electrotechnical standardization.

The procedures used to develop this document and those intended for its further maintenance are described in the ISO/IEC Directives, Part 1. In particular, the different approval criteria needed for the different types of ISO document should be noted. This document was drafted in accordance with the editorial rules of the ISO/IEC Directives, Part 2 (see www.iso.org/directives).

ISO draws attention to the possibility that the implementation of this document may involve the use of (a) patent(s). ISO takes no position concerning the evidence, validity or applicability of any claimed patent rights in respect thereof. As of the date of publication of this document, ISO had not received notice of (a) patent(s) which may be required to implement this document. However, implementers are cautioned that this may not represent the latest information, which may be obtained from the patent database available at www.iso.org/patents. ISO shall not be held responsible for identifying any or all such patent rights.

Any trade name used in this document is information given for the convenience of users and does not constitute an endorsement.

For an explanation of the voluntary nature of standards, the meaning of ISO specific terms and expressions related to conformity assessment, as well as information about ISO's adherence to the World Trade Organization (WTO) principles in the Technical Barriers to Trade (TBT), see www.iso.org/iso/foreword.html.

This document was prepared by Technical Committee ISO/TC 131, *Fluid power systems*, Subcommittee SC 5, *Control products and components*.

This fourth edition cancels and replaces the third edition (ISO 6953-1:2015), which has been technically revised.

The main changes are as follows:

- deletion of Annex A.

A list of all parts in the ISO 6953 series can be found on the ISO website.

Any feedback or questions on this document should be directed to the user's national standards body. A complete listing of these bodies can be found at www.iso.org/members.html.

Introduction

In pneumatic fluid power systems, power is transmitted and controlled through a gas under pressure within a circuit.

When pressure reduction or pressure regulation is required, regulators and filter-regulators are components designed to maintain the pressure of the gas at an approximately constant level.

It is, therefore, necessary to know some performance characteristics of these components in order to determine their suitability for an application.

iTeh STANDARD PREVIEW
(standards.iteh.ai)

ISO 6953-1

<https://standards.iteh.ai/catalog/standards/sist/e8401fb2-a9b8-4a90-89d6-7bccc8c001d9/iso-6953-1>

Pneumatic fluid power — Compressed air pressure regulators and filter-regulators —

Part 1:

Main characteristics to include in supplier's literature and product-marking requirements

1 Scope

This document specifies which characteristics of compressed air pressure regulators are required to be included in the literature from the supplier. It also applies to filter-regulators.

This document applies to:

- manually controlled direct operated types (with relieving mechanisms such as a relieving pressure regulator, or without relieving mechanism),
- manually controlled internal pilot operating types (e.g. nozzle flapper), and
- pressure-pilot operated types.

In addition, it specifies the product marking requirements for pressure regulators and filter-regulators.

This document is applicable to compressed air pressure regulators with a rated inlet pressure of up to 2 500 kPa (25 bar)¹⁾ and an outlet adjustment pressure of up to 1 600 kPa (16 bar) and to filter-regulators with rated inlet and outlet pressures of up to 1 600 kPa (16 bar), in which the major contaminants are removed by mechanical means. [iso-6953-1](#)

NOTE The main characteristics to be included in the supplier's literature related to electrically modulated pneumatic continuous pressure control valves are specified in ISO 10094-1.

2 Normative references

The following documents are referred to in the text in such a way that some or all of their content constitutes requirements of this document. For dated references, only the edition cited applies. For undated references, the latest edition of the referenced document (including any amendments) applies.

ISO 2944, *Fluid power systems and components — Nominal pressures*

ISO 5598, *Fluid power systems and components — Vocabulary*

ISO 5782-2:1997, *Pneumatic fluid power — Compressed-air filters — Part 2: Test methods to determine the main characteristics to be included in supplier's literature*

ISO 6358-1, *Pneumatic fluid power — Determination of flow-rate characteristics of components using compressible fluids — Part 1: General rules and test methods for steady-state flow*

ISO 6953-2:—²⁾, *Pneumatic fluid power — Compressed air pressure regulators and filter-regulators — Part 2: Test methods to determine the main characteristics to be included in literature from suppliers*

1) 1 bar = 0,1 MPa = 10⁵ Pa; 1 MPa = 1 N/mm²

2) Under preparation. Stage at the time of publication: ISO/FDIS 6953-2:2023.

ISO 10094-1, *Pneumatic fluid power — Electro-pneumatic pressure control valves — Part 1: Main characteristics to include in the supplier's literature*

ISO 11727, *Pneumatic fluid power — Identification of ports and control mechanisms of control valves and other components*

3 Terms and definitions

For the purposes of this document, the terms and definitions given in ISO 5598, ISO 6358-1, ISO 10094-1 and the following apply.

ISO and IEC maintain terminology databases for use in standardization at the following addresses:

- ISO Online browsing platform: available at <https://www.iso.org/obp>
- IEC Electropedia: available at <https://www.electropedia.org/>

3.1 compressed air pressure regulator
component designed to maintain compressed air pressure, approximately constant within an enclosed circuit despite variation in operating flow rate and inlet pressure

3.2 manual air pressure regulator
compressed air pressure regulator (3.1) in which the outlet pressure is set by using a control knob

3.3 pressure-pilot air pressure regulator
compressed air pressure regulator (3.1) in which the outlet pressure is set by using pressure piloting

3.4 relieving pressure regulator
pressure regulator equipped with an unloading device that opens if the regulated pressure exceeds the original setting by a sufficient degree, and exhausts a limited flow rate of air from the outlet circuit to the atmosphere

3.5 filter-regulator
device that combines the filter and regulator onto one body as a single unit

Note 1 to entry: In such a device, the filter is always on the upstream side of the regulator.

3.6 pilot-operated regulator with air bleed
regulator designed to minimize the variation of regulated pressure from its set point during flow, using a pilot supply that continuously flows through the pilot chamber and is exhausted

3.7 flow rate-pressure characteristic curve
graphical representation of the relationship between the regulated pressure and the forward flow rate or the relief flow rate while the outlet set pressure and the inlet pressure are maintained constant

Note 1 to entry: The flow rate-pressure characteristic curve is forward (if the flow direction is from the inlet to the outlet), or relief (if the flow direction is from the outlet to the relieving mechanism).

3.8 pressure regulation characteristic
graphical representation of regulated pressure variation caused by changes in inlet (supply) pressure, at a constant small air flow rate and low regulated pressure

4 Technical requirements

4.1 General

Descriptive literature covering compressed air pressure regulators and filter-regulators shall include the characteristics given in 4.2 and 4.3.

4.2 General characteristics

4.2.1 General dimensions

The dimensions shown on Figure 1 shall be given in millimetres. For ports, see 4.2.2.

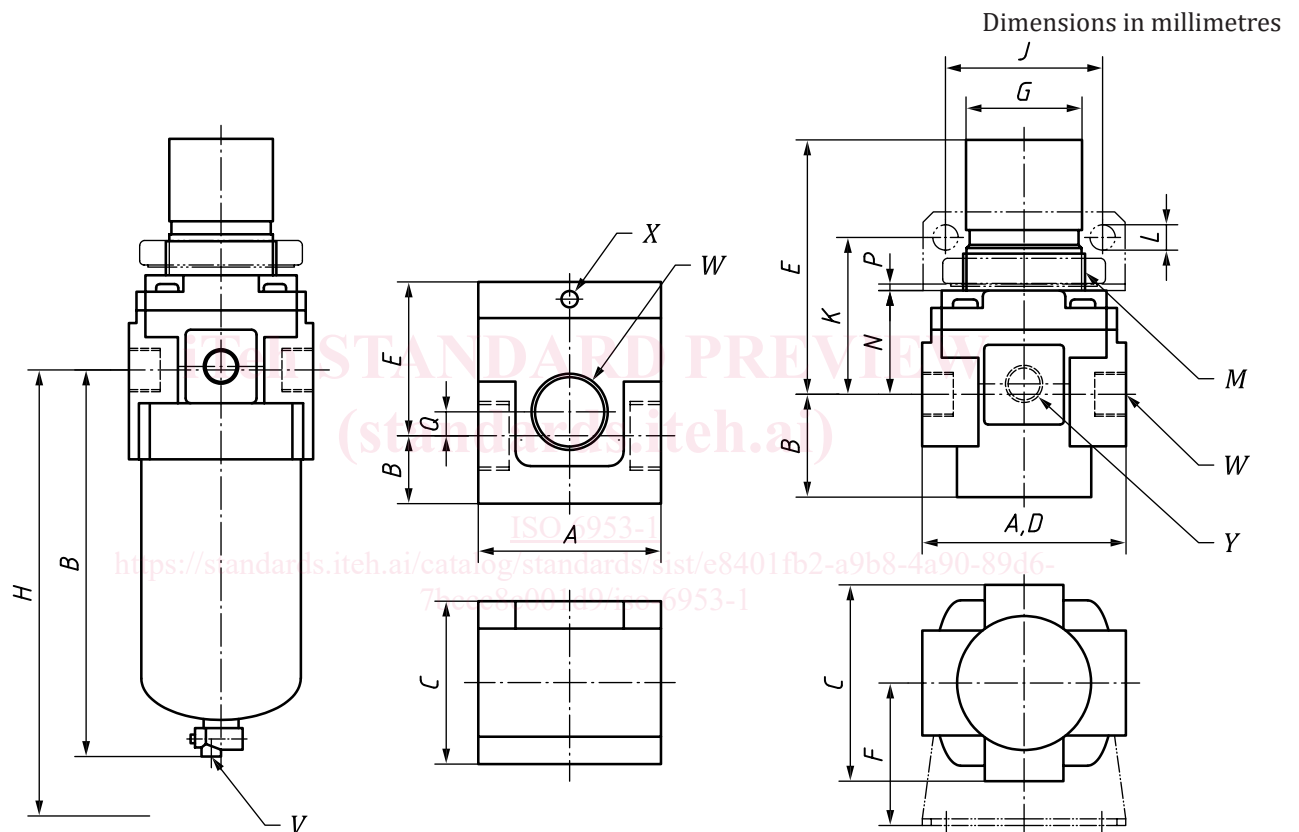

Key

- A maximum overall width
- B maximum installation height below the port centre line
- C maximum overall depth, excluding pressure gauge
- D distance between the faces of the compressed air connection (inlet/outlet)
- E maximum height above the port centre line
- F^a maximum installation depth from the port centre line
- G maximum dimension of the regulated pressure adjusting device
- H minimum clearance from the port centre line to permit dismantling
- J^a distance between mounting holes
- K^a distance between the port centre line and mounting holes
- L^a minimum recommended diameter and length of mounting holes
- M^a panel mounting thread
- N^a panel mounting height above the port centre line

P^a	maximum panel thickness
Q^b	distance between the port centre line to gage port
V	drain hole description
W	port description
X^b	pilot port description
Y	pressure gauge port description

NOTE ^a Dimensions, F, J, K, L, M, N , and P are indicated only if the device has provisions for mounting.
^b Optional.

Figure 1 — Dimensions of compressed air regulators and filter-regulators

4.2.2 Port forms

Port forms should be selected from ISO 16030 or the ISO 1179 series for ports with pipe parallel threads, or from ISO 7-1 for ports with pipe-tapered threads.

The connecting interface for flange-mounted designs can be plain ported and counter bored to accept O-rings.

For certain applications and connections, other port forms can be employed.

4.2.3 Rated pressure

Compressed air pressure regulators and filter-regulators shall be classified according to their rated pressure, selected from ISO 2944.

The rated pressure shall be verified using the test procedure specified in ISO 6953-2:—²), Clause 6. This procedure verifies the pressure rating of the pressure-containing envelope but does not cover the limitation that can be imposed by the diaphragm. The range of duties and sensitivities of the diaphragm used vary widely and their strength can be limited to achieve the accuracy required by the application.

4.2.4 Range of operating temperatures

4.2.4.1 The temperature range in which the material and the operation of the pressure regulator and filter-regulator are not impaired shall be stated.

4.2.4.2 Other combinations of pressure and temperature ratings for optional designs that can require a different rating shall be specified.

4.3 Particular requirements

4.3.1 General

The data provided by the supplier shall assist the user in selecting the compressed air pressure regulator and filter-regulator best suited for the particular application.

4.3.2 Adjustable pressure ranges (outlet regulated pressure)

The upper limit of the recommended adjustable pressure range should normally be chosen from the following preferred ranges but not to exceed the inlet rated pressure:

- up to 100 kPa (1 bar);
- up to 200 kPa (2 bar);