



Designation: C1585 – 13

# Standard Test Method for Measurement of Rate of Absorption of Water by Hydraulic- Cement Concretes<sup>1</sup>

This standard is issued under the fixed designation C1585; the number immediately following the designation indicates the year of original adoption or, in the case of revision, the year of last revision. A number in parentheses indicates the year of last reapproval. A superscript epsilon ( $\epsilon$ ) indicates an editorial change since the last revision or reapproval.

## 1. Scope\*

1.1 This test method is used to determine the rate of absorption (sorptivity) of water by hydraulic cement concrete by measuring the increase in the mass of a specimen resulting from absorption of water as a function of time when only one surface of the specimen is exposed to water. The specimen is conditioned in an environment at a standard relative humidity to induce a consistent moisture condition in the capillary pore system. The exposed surface of the specimen is immersed in water and water ingress of unsaturated concrete is dominated by capillary suction during initial contact with water.

1.2 The values stated in SI units are to be regarded as standard. No other units of measurement are included in this standard.

1.3 *This standard does not purport to address all of the safety concerns, if any, associated with its use. It is the responsibility of the user of this standard to establish appropriate safety and health practices and determine the applicability of regulatory limitations prior to use.*

## 2. Referenced Documents

2.1 *ASTM Standards:*<sup>2</sup>

[C31/C31M Practice for Making and Curing Concrete Test Specimens in the Field](#)

[C42/C42M Test Method for Obtaining and Testing Drilled Cores and Sawed Beams of Concrete](#)

[C125 Terminology Relating to Concrete and Concrete Aggregates](#)

[C192/C192M Practice for Making and Curing Concrete Test Specimens in the Laboratory](#)

[C642 Test Method for Density, Absorption, and Voids in Hardened Concrete](#)

<sup>1</sup> This test method is under the jurisdiction of ASTM Committee C09 on Concrete and Concrete Aggregates and is the direct responsibility of Subcommittee C09.66 on Concrete's Resistance to Fluid Penetration.

Current edition approved Feb. 1, 2013. Published February 2013. Originally approved in 2004. Last previous edition approved in 2011 as C1585 – 11. DOI: 10.1520/C1585-13.

<sup>2</sup> For referenced ASTM standards, visit the ASTM website, [www.astm.org](http://www.astm.org), or contact ASTM Customer Service at [service@astm.org](mailto:service@astm.org). For *Annual Book of ASTM Standards* volume information, refer to the standard's Document Summary page on the ASTM website.

[C1005 Specification for Reference Masses and Devices for Determining Mass and Volume for Use in the Physical Testing of Hydraulic Cements](#)

[C1202 Test Method for Electrical Indication of Concrete's Ability to Resist Chloride Ion Penetration](#)

## 3. Terminology

3.1 *Definitions*—For definitions of terms used in this standard, refer to Terminology [C125](#).

## 4. Significance and Use

4.1 The performance of concrete subjected to many aggressive environments is a function, to a large extent, of the penetrability of the pore system. In unsaturated concrete, the rate of ingress of water or other liquids is largely controlled by absorption due to capillary rise. This test method is based on that developed by Hall<sup>3</sup> who called the phenomenon “water sorptivity.”

4.2 The water absorption of a concrete surface depends on many factors including: (a) concrete mixture proportions; (b) the presence of chemical admixtures and supplementary cementitious materials; (c) the composition and physical characteristics of the cementitious component and of the aggregates; (d) the entrained air content; (e) the type and duration of curing; (f) the degree of hydration or age; (g) the presence of microcracks; (h) the presence of surface treatments such as sealers or form oil; and (i) placement method including consolidation and finishing. Water absorption is also strongly affected by the moisture condition of the concrete at the time of testing.

4.3 This method is intended to determine the susceptibility of an unsaturated concrete to the penetration of water. In general, the rate of absorption of concrete at the surface differs from the rate of absorption of a sample taken from the interior. The exterior surface is often subjected to less than intended curing and is exposed to the most potentially adverse conditions. This test method is used to measure the water absorption rate of both the concrete surface and interior concrete. By drilling a core and cutting it transversely at selected depths, the

<sup>3</sup> Hall, C., “Water Sorptivity of Mortars and Concretes: A Review,” *Magazine of Concrete Research*, Vol 41, No. 147, June 1989, pp. 51–61.

\*A Summary of Changes section appears at the end of this standard

absorption can be evaluated at different distances from the exposed surface. The core is drilled vertically or horizontally.

4.4 This test method differs from Test Method C642 in which the specimens are oven dried, immersed completely in water at 21°C, and then boiled under water for 5 h. In this test method, only one surface is exposed to water at room temperature while the other surfaces are sealed simulating water absorption in a member that is in contact with water on one side only. Test Method C642, on the other hand, is used to estimate the maximum amount of water that can be absorbed by a dry specimen and therefore provides a measure of the total, water permeable pore space.

## 5. Apparatus

5.1 *Pan*, a watertight polyethylene or other corrosion-resistant pan large enough to accommodate the test specimens with the surfaces to be tested exposed to water.

5.2 *Support Device*, rods, pins, or other devices, which are made of materials resistant to corrosion by water or alkaline solutions, and which allow free access of water to the exposed surface of the specimen during testing. Alternatively, the specimens can be supported on several layers of blotting paper or filter papers with a total thickness of at least 1 mm.

5.3 *Top-pan Balance*, complying with Specification C1005 and with sufficient capacity for the test specimens and accurate to at least  $\pm 0.01$  g.

5.4 *Timing Device*, stop watch or other suitable timing device accurate to  $\pm 1$  s.

5.5 *Paper Towel or Cloth*, for wiping excess water from specimen surfaces.

5.6 *Water-Cooled Saw*, with diamond impregnated blade to cut test specimens from larger samples.

5.7 *Environmental Chamber*, a chamber allowing for air circulation and able to maintain a temperature of  $50 \pm 2^\circ\text{C}$  and a relative humidity at  $80 \pm 3\%$ . Alternatively, an oven able to maintain a temperature of  $50 \pm 2^\circ\text{C}$  and a desiccator large enough to contain the specimens to be tested is permitted. The relative humidity (RH) is controlled in the desiccator at  $80 \pm 0.5\%$  by a saturated solution of potassium bromide. The solubility of potassium bromide is 80.2 g/100 g of water at 50°C. The solution shall be maintained at the saturation point for the duration of the test. The presence of visible crystals in the solution provides acceptable evidence of saturation.

5.8 *Polyethylene Storage Containers*, with sealable lids, large enough to contain at least one test specimen but not larger than 5 times the specimen volume.

5.9 *Caliper*, to measure the specimen dimensions to the nearest 0.1 mm.

## 6. Reagents and Materials

6.1 *Potassium Bromide, Reagent Grade*, required if the oven and desiccator system described in 5.7 is used.

6.2 *Sealing Material*, strips of low permeability adhesive sheets, epoxy paint, vinyl electrician's tape, duct tape, or

aluminium tape. The material shall not require a curing time longer than 10 minutes.

6.3 *Plastic Bag or Sheeting*, any plastic bag or sheeting that could be attached to the specimen to control evaporation from the surface not exposed to water. An elastic band is required to keep the bag or sheeting in place during the measurements.

## 7. Test Specimens

7.1 The standard test specimen is a  $100 \pm 6$  mm diameter disc, with a length of  $50 \pm 3$  mm. Specimens are obtained from either molded cylinders according to Practices C31/C31M or C192/C192M or drilled cores according to Test Method C42/C42M. The cross sectional area of a specimen shall not vary more than 1 % from the top to the bottom of the specimen. When cores are taken, they should be marked (see Note 1) so that the surface to be tested relative to the original location in the structure is clearly indicated.

NOTE 1—The surface to be exposed during testing shall not be marked or otherwise disturbed in such a manner as may modify the absorption rate of the specimen.

7.2 The average test results on at least 2 specimens (Note 2) shall constitute the test result. The test surfaces shall be at the same distance from the original exposed surface of the concrete.

NOTE 2—Concrete is not a homogeneous material. Also, an exterior surface of a concrete specimen seldom has the same porosity as the interior concrete. Therefore, replicate measurements are taken on specimens from the same depth to reduce the scatter of the data.

## 8. Sample Conditioning

8.1 Before conditioning drilled core specimens obtained from the field, first saturate them in accordance with the vacuum-saturation procedure in Test Method C1202, but omit the step for coating specimen side surfaces.

8.2 After saturating, measure the mass of each test specimen to the nearest 0.01 g.

8.3 Place test specimens in the environmental chamber at a temperature of  $50 \pm 2^\circ\text{C}$  and RH of  $80 \pm 3\%$  for 3 days. Alternatively, place test specimens in a desiccator inside an oven at a temperature of  $50 \pm 2^\circ\text{C}$  for 3 days. If the desiccator is used, control the relative humidity in the desiccator with a saturated solution of potassium bromide (see 5.7), but do not allow test specimens to contact the solution.

NOTE 3—If the RH is controlled using a saturated potassium bromide solution, the solution should be placed in the bottom of the desiccator, rather than in a separate container, to maximize the exposed surface area of the solution.

8.4 After the 3 days, place each specimen inside a sealable container (as defined in 5.8). Use a separate container for each specimen. Precautions must be taken to allow free flow of air around the specimen by ensuring minimal contact of the specimen with the walls of the container.

8.5 Store the container at  $23 \pm 2^\circ\text{C}$  for at least 15 days before the start of the absorption procedure.

NOTE 4—Storage in the sealed container for at least 15 days results in equilibration of the moisture distribution within the test specimens and has

been found<sup>4</sup> to provide internal relative humidities of 50 to 70 %. This is similar to the relative humidities found near the surface in some field structures.<sup>5, 6</sup>

**9. Procedure**

9.1 Remove the specimen from the storage container and record the mass of the conditioned specimen to the nearest 0.01 g before sealing of side surfaces.

9.2 Measure at least four diameters of the specimen at the surface to be exposed to water. Measure the diameters to the nearest 0.1 mm and calculate the average diameter to the nearest 0.1 mm.

9.3 Seal the side surface of each specimen with a suitable sealing material. Seal the end of the specimen that will not be exposed to water using a loosely attached plastic sheet (see 6.2). The plastic sheet can be secured using an elastic band or other equivalent system (see Fig. 1).

9.4 Use the procedure below to determine water absorption as a function of time. Conduct the absorption procedure at  $23 \pm 2^\circ\text{C}$  with tap water conditioned to the same temperature.

*9.5 Absorption Procedure:*

9.5.1 Measure the mass of the sealed specimen to the nearest 0.01 g and record it as the initial mass for water absorption calculations.

9.5.2 Place the support device at the bottom of the pan and fill the pan with tap water so that the water level is 1 to 3 mm

above the top of the support device. Maintain the water level 1 to 3 mm above the top of the support device for the duration of the tests.

NOTE 5—One method for keeping the water level constant is to install a water-filled bottle upside down such that the bottle opening is in contact with the water at the desired level.

9.5.3 Start the timing device and immediately place the test surface of the specimen on the support device (see Fig. 1). Record the time and date of initial contact with water.

9.5.4 Record the mass at the intervals shown in Table 1 after first contact with water. Using the procedure in 9.5.5, the first point shall be at  $60 \pm 2$  s and the second point at 5 min  $\pm 10$  s. Subsequent measurements shall be within  $\pm 2$  min of 10 min, 20 min, 30 min, and 60 min. The actual time shall be recorded to within  $\pm 10$  s. Continue the measurements every hour,  $\pm 5$  min, up to 6 h, from the first contact of the specimen with water and record the time within  $\pm 1$  min. After the initial 6 h, take measurements once a day up to 3 days, followed by 3 measurements at least 24 h apart during days 4 to 7; take a final measurement that is at least 24 h after the measurement at 7 days. The actual time of measurements shall be recorded within  $\pm 1$  min. This will result in seven data points for contact time during days 2 through 8. Table 1 gives the target times of measurements and the tolerances for the times.

9.5.5 For each mass determination, remove the test specimen from the pan, stop the timing device if the contact time is less than 10 min, and blot off any surface water with a dampened paper towel or cloth. After blotting to remove excess water, invert the specimen so that the wet surface does not come in contact with the balance pan (to avoid having to dry the balance pan). Within 15 s of removal from the pan, measure the mass to the nearest 0.01 g. Immediately replace the specimen on the support device and restart the timing device.

**10. Calculations**

10.1 The absorption, *I*, is the change in mass divided by the product of the cross-sectional area of the test specimen and the

<sup>4</sup> Bentz, D. P., Ehlen, M. A., Ferraris, C. F., and Winpigler, J. A., "Service Life Prediction Based on Sorptivity for Highway Concrete Exposed to Sulfate Attack and Freeze-Thaw Conditions," FHWA-RD-01-162, 2001.

<sup>5</sup> DeSouza, S. J., Hooton R. D., and Bickley J. A., "Evaluation of Laboratory Drying Procedures Relevant to Field Conditions for Concrete Sorptivity Measurements," *Cement, Concrete and Aggregates*, Vol 19, No. 2, December 1997, pp. 59-63.

<sup>6</sup> DeSouza, S. J., Hooton, R. D., and Bickley, J. A., "A Field Test for Evaluating High Performance Concrete Covercrete Quality," *Canadian Journal of Civil Engineering*, Vol 25, No. 3, June 1998, pp. 551-556.

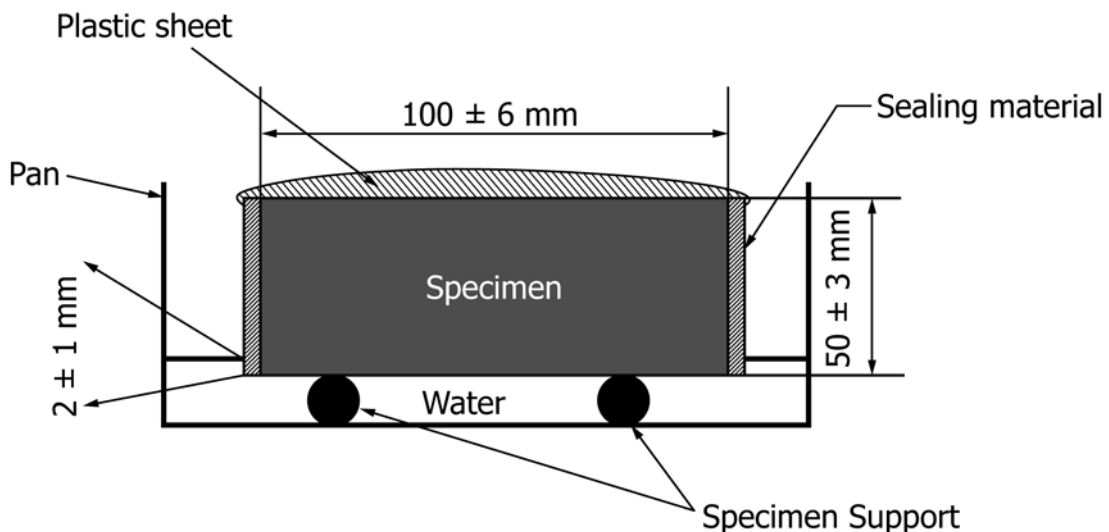

FIG. 1 Schematic of the Procedure