



Designation: ~~D97~~—~~11~~ **D97 – 12**



Designation: 15/95

## Standard Test Method for Pour Point of Petroleum Products<sup>1</sup>

This standard is issued under the fixed designation D97; the number immediately following the designation indicates the year of original adoption or, in the case of revision, the year of last revision. A number in parentheses indicates the year of last reapproval. A superscript epsilon ( $\epsilon$ ) indicates an editorial change since the last revision or reapproval.

*This standard has been approved for use by agencies of the Department of Defense.*

### 1. Scope\*

1.1 This test method covers and is intended for use on any petroleum product.<sup>2</sup> A procedure suitable for black specimens, cylinder stock, and nondistillate fuel oil is described in 8.8. The cloud point procedure formerly part of this test method now appears as Test Method **D2500**.

1.2 Currently there is no ASTM test method for automated Test Method D97 pour point measurements.

1.3 Several ASTM test methods offering alternative procedures for determining pour points using automatic apparatus are available. None of them share the same designation number as Test Method D97. When an automatic instrument is used, the ASTM test method designation number specific to the technique shall be reported with the results. A procedure for testing the pour point of crude oils is described in Test Method **D5853**.

1.4 The values stated in SI units are to be regarded as standard. No other units of measurement are included in this standard.

1.5 **WARNING**—Mercury has been designated by many regulatory agencies as a hazardous material that can cause central nervous system, kidney and liver damage. Mercury, or its vapor, may be hazardous to health and corrosive to materials. Caution should be taken when handling mercury and mercury containing products. See the applicable product Material Safety Data Sheet (MSDS) for details and EPA's website—<http://www.epa.gov/mercury/faq.htm>—for additional information. Users should be aware that selling mercury and/or mercury containing products into your state or country may be prohibited by law.

1.6 *This standard does not purport to address all of the safety concerns, if any, associated with its use. It is the responsibility of the user of this standard to establish appropriate safety and health practices and determine the applicability of regulatory limitations prior to use.*

[ASTM D97-12](#)

### 2. Referenced Documents

2.1 *ASTM Standards:*<sup>3</sup>

[D117 Guide for Sampling, Test Methods, and Specifications for Electrical Insulating Oils of Petroleum Origin](#)

[D396 Specification for Fuel Oils](#)

[D2500 Test Method for Cloud Point of Petroleum Products](#)

[D5853 Test Method for Pour Point of Crude Oils](#)

[D6300 Practice for Determination of Precision and Bias Data for Use in Test Methods for Petroleum Products and Lubricants](#)

[E1 Specification for ASTM Liquid-in-Glass Thermometers](#)

2.2 *Energy Institute Standards:*

[Specifications for IP Standard Thermometers](#)<sup>4</sup>

### 3. Terminology

3.1 *Definitions:*

<sup>1</sup> This test method is under the jurisdiction of ASTM Committee **D02** on Petroleum Products and Lubricants and is the direct responsibility of Subcommittee **D02.07** on Flow Properties.

Current edition approved ~~June 1, 2011~~ Dec. 1, 2012. Published ~~July 2011~~ March 2013. Originally approved in 1927, replacing D47. Last previous edition approved in ~~2009~~ 2011 as D97-09-11. DOI: ~~10.1520/D0097-11~~ 10.1520/D0097-12.

In the IP, this test method is under the jurisdiction of the Standardization Committee. This test method was adopted as a joint ASTM-IP Standard in 1965.

<sup>2</sup> Statements defining this test and its significance when applied to electrical insulating oils of mineral origin will be found in Guide **D117**.

<sup>3</sup> For referenced ASTM standards, visit the ASTM website, [www.astm.org](http://www.astm.org), or contact ASTM Customer Service at [service@astm.org](mailto:service@astm.org). For *Annual Book of ASTM Standards* volume information, refer to the standard's Document Summary page on the ASTM website.

<sup>4</sup> Methods for Analysis and Testing, *IP Standards for Petroleum and its Products*, Part I, Vol 2.

\*A Summary of Changes section appears at the end of this standard

3.1.1 *black oil, n*—lubricant containing asphaltic materials. Black oils are used in heavy-duty equipment applications, such as mining and quarrying, where extra adhesiveness is desired.

3.1.2 *cylinder stock, n*—lubricant for independently lubricated engine cylinders, such as those of steam engines and air compressors. Cylinder stock are also used for lubrication of valves and other elements in the cylinder area.

3.1.3 *pour point, n*—in petroleum products, the lowest temperature at which movement of the test specimen is observed under prescribed conditions of test.

3.1.4 *residual fuel, n*—a liquid fuel containing bottoms remaining from crude distillation or thermal cracking; sometimes referred to as heavy fuel oil.

3.1.4.1 *Discussion*—

Residual fuels comprise Grades 4, 5, and 6 fuel oils, as defined in Specification D396.

4. Summary of Test Method

4.1 After preliminary heating, the sample is cooled at a specified rate and examined at intervals of 3°C for flow characteristics. The lowest temperature at which movement of the specimen is observed is recorded as the pour point.

5. Significance and Use

5.1 The pour point of a petroleum specimen is an index of the lowest temperature of its utility for certain applications.

6. Apparatus

6.1 *Test Jar*, cylindrical, of clear glass, flat bottom, 33.2 to 34.8-mm outside diameter, and 115 to 125 mm in height. The inside diameter of the jar can range from 30.0 to 32.4 mm, within the constraint that the wall thickness be no greater than 1.6 mm. The jar shall have a line to indicate a sample height  $54 \pm 3$  mm above the inside bottom. See Fig. 1.

6.2 *Thermometers*, having the following ranges and conforming to the requirements prescribed in Specification E1 for thermometers:

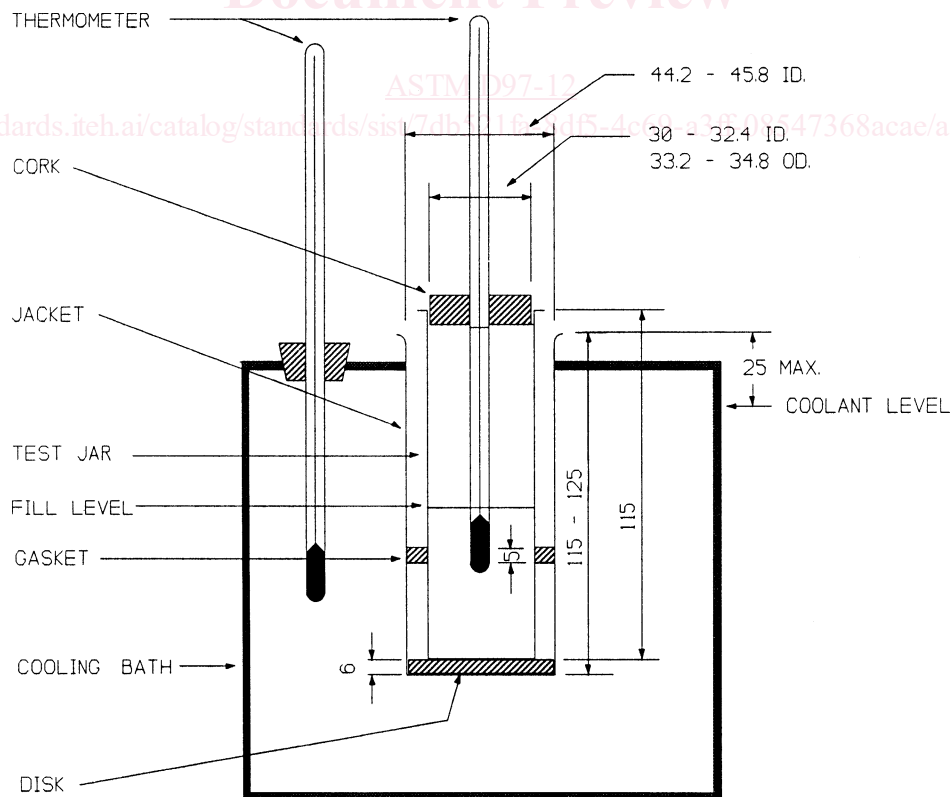

NOTE 1—Dimensions are in millimetres (not to scale).

FIG. 1 Apparatus for Pour Point Test

Thermometer	Temperature Range	ASTM	Thermometer Number	IP
High cloud and pour	-38 to +50°C	5C		1C
Low cloud and pour	-80 to +20°C	6C		2C
Melting point	+32 to +127°C	61C		63C

6.2.1 Since separation of liquid column thermometers occasionally occurs and may escape detection, thermometers should be checked immediately prior to the test and used only if they prove accurate within  $\pm 1^\circ\text{C}$  (for example ice point).

6.3 *Cork*, to fit the test jar, bored centrally for the test thermometer.

6.4 *Jacket*, watertight, cylindrical, metal, flat-bottomed,  $115 \pm 3$ -mm depth, with inside diameter of 44.2 to 45.8 mm. It shall be supported in a vertical position in the cooling bath (see 6.7) so that not more than 25 mm projects out of the cooling medium, and shall be capable of being cleaned.

6.5 *Disk*, cork or felt, 6 mm thick to fit loosely inside the jacket.

6.6 *Gasket*, to fit snugly around the outside of the test jar and loosely inside the jacket. The gasket may be made of rubber, leather, or other material that is elastic enough to cling to the test jar and hard enough to hold its shape. Its purpose is to prevent the test jar from touching the jacket.

6.7 *Bath or Baths*, maintained at prescribed temperatures with a firm support to hold the jacket vertical. The required bath temperatures may be obtained by refrigeration if available, otherwise by suitable cooling mixtures. Cooling mixtures commonly used for bath temperatures down to those shown are in Table 1.

## 7. Reagents and Materials

7.1 The following solvents of technical grade are appropriate for low-temperature bath media.

7.1.1 *Acetone*, (**Warning**—Extremely flammable).

7.1.2 *Alcohol, Ethanol* (**Warning**—Flammable).

7.1.3 *Alcohol, Methanol* (**Warning**—Flammable. Vapor harmful).

7.1.4 *Petroleum Naphtha*, (**Warning**—Combustible. Vapor harmful).

7.1.5 *Solid Carbon Dioxide*, (**Warning**—Extremely cold  $-78.5^\circ\text{C}$ ).

## 8. Procedure

8.1 Pour the specimen into the test jar to the level mark. When necessary, heat the specimen in a bath until it is just sufficiently fluid to pour into the test jar.

NOTE 1—It is known that some materials, when heated to a temperature higher than  $45^\circ\text{C}$  during the preceding 24 h, do not yield the same pour point results as when they are kept at room temperature for 24 h prior to testing. Examples of materials which are known to show sensitivity to thermal history are residual fuels, black oils, and cylinder stocks.

8.1.1 Samples of residual fuels, black oils, and cylinder stocks which have been heated to a temperature higher than  $45^\circ\text{C}$  during the preceding 24 h, or when the thermal history of these sample types is not known, shall be kept at room temperature for 24 h before testing. Samples which are known by the operator not to be sensitive to thermal history need not be kept at room temperature for 24 h before testing.

**TABLE 1 Cooling Mixtures and Bath Temperatures**

Cooling Mixture	Bath Temperature
Ice and water	$0 \pm 1.5^\circ\text{C}$
Crushed ice and sodium chloride crystals or Acetone or petroleum naphtha, or methanol or ethanol (see Section 7) with solid carbon dioxide added to give the desired temperature	$-18 \pm 1.5^\circ\text{C}$
Acetone or petroleum naphtha or methanol or ethanol (see Section 7) with solid carbon dioxide added to give the desired temperature	$-33 \pm 1.5^\circ\text{C}$
Acetone or petroleum naphtha or methanol or ethanol (see Section 7) with solid carbon dioxide added to give the desired temperature	$-51 \pm 1.5^\circ\text{C}$
Acetone or petroleum naphtha or methanol or ethanol (see Section 7) with solid carbon dioxide added to give the desired temperature	$-69 \pm 1.5^\circ\text{C}$