



Designation: D446 – 12



Designation: 71/2/95

## Standard Specifications and Operating Instructions for Glass Capillary Kinematic Viscometers<sup>1</sup>

This standard is issued under the fixed designation D446; the number immediately following the designation indicates the year of original adoption or, in the case of revision, the year of last revision. A number in parentheses indicates the year of last reapproval. A superscript epsilon ( $\epsilon$ ) indicates an editorial change since the last revision or reapproval.

*This standard has been approved for use by agencies of the U.S. Department of Defense.*

### 1. Scope\*

1.1 These specifications cover operating instructions for glass capillary kinematic viscometers of all the types described in detail in [Annex A1](#), [Annex A2](#), and [Annex A3](#) as follows:

Modified Ostwald viscometers, [Annex A1](#)  
Suspended-level viscometers, [Annex A2](#)  
Reverse-flow viscometers, [Annex A3](#)

1.2 The calibration of the viscometers is described in Section 6.

1.3 This standard covers some widely used viscometers suitable for use in accordance with Test Method [D445](#). Other viscometers of the glass capillary type which are capable of measuring kinematic viscosity within the limits of precision given in Test Method [D445](#) may be used.

1.4 The values stated in SI units are to be regarded as standard. No other units of measurement are included in this standard.

### 2. Referenced Documents

- 2.1 *ASTM Standards*:<sup>2</sup>  
[D445 Test Method for Kinematic Viscosity of Transparent and Opaque Liquids \(and Calculation of Dynamic Viscosity\)](#)  
[D2162 Practice for Basic Calibration of Master Viscometers and Viscosity Oil Standards](#)
- 2.2 *ISO Documents*:<sup>3</sup>  
[ISO 3104 Petroleum Products—Transparent and Opaque Liquids—Determination of Kinematic Viscosity and Calculation of Dynamic Viscosity](#)

<sup>1</sup> These specifications and operating instructions are under the jurisdiction of ASTM Committee D02 on Petroleum Products, Liquid Fuels, and Lubricants and are the direct responsibility of Subcommittee D02.07 on Flow Properties.

Current edition approved Dec. 1, 2012. Published March 2013. Originally approved in 1966 as D2515 – 66. Redesignated D446 in 1977. Last previous edition approved in 2007 as D446 – 07. DOI: 10.1520/D0446-12.

<sup>2</sup> For referenced ASTM standards, visit the ASTM website, www.astm.org, or contact ASTM Customer Service at service@astm.org. For *Annual Book of ASTM Standards* volume information, refer to the standard's Document Summary page on the ASTM website.

<sup>3</sup> Available from American National Standards Institute (ANSI), 25 W. 43rd St., 4th Floor, New York, NY 10036.

[ISO 3105 Glass Capillary Kinematic Viscometers—Specifications and Operating Instructions](#)

[ISO 5725 Basic Methods for the Determination of Repeatability and Reproducibility of a Standard Measurement Method](#)

[ISO 17025 General Requirements for the Competence of Testing and Calibration Laboratories](#)

[ISO Guide 25 General Requirements for the Calibration and Testing Laboratories](#)

2.3 *NIST Standards*:<sup>4</sup>

[NIST 1297 Guidelines for Evaluating and Expressing the Uncertainty of NIST Measurement Results](#)

### 3. Materials and Manufacture

3.1 Fully annealed, low-expansion borosilicate glass shall be used for the construction of all viscometers. The size number, serial number, and manufacturer's designation shall be permanently marked on each viscometer. All timing marks shall be etched and filled with an opaque color, or otherwise made a permanent part of the viscometer. See detailed description of each type of viscometer in [Annex A1](#), [Annex A2](#), and [Annex A3](#).

3.2 With the exception of the FitzSimons and Atlantic viscometers, all viscometers are designed to fit through a 51-mm hole in the lid of a constant-temperature bath having a liquid depth of at least 280 mm; and it is assumed that the surface of the liquid will be not more than 45 mm from the top of the bath lid. For certain constant-temperature baths, especially at low or high temperatures, it may be necessary to construct the viscometers with the uppermost tubes longer than shown to ensure adequate immersion in the constant-temperature bath. Viscometers so modified can be used to measure kinematic viscosity within the precision of the test method. The lengths of tubes and bulbs on the figures should be held within  $\pm 10\%$  or  $\pm 10$  mm, whichever is less, such that the calibration constant of the viscometer does not vary by more than  $\pm 15\%$  from the nominal value.

<sup>4</sup> Available from National Institute of Standards and Technology (NIST), 100 Bureau Dr., Stop 1070, Gaithersburg, MD 20899-1070, <http://www.nist.gov>.

\*A Summary of Changes section appears at the end of this standard

## 4. Nomenclature for Figures

4.1 The figures in the annexes contain letters to designate specific parts of each viscometer. These letters are also used in the text of the standard when reference to the viscometers is given. The more frequently used letters on the figures in the annexes are as follows:

A	lower reservoir
B	suspended level bulb
C and J	timing bulbs
D	upper reservoir
E, F, and I	timing marks
G and H	filling marks
K	overflow tube
L	mounting tube
M	lower vent tube
N	upper vent tube
P	connecting tube
R	working capillary

## 5. Viscometer Holder and Alignment

5.1 All viscometers which have the upper meniscus directly above the lower meniscus (Cannon-Fenske routine in [Annex A1](#) and all in [Annex A2](#)) shall be mounted in a constant temperature bath with tube L held within 1° of the vertical as observed with a plumb bob or other equally accurate inspection means. A number of commercially available holders are so designed that the tube L is held perpendicular to the lid of a constant-temperature bath; nevertheless, the viscometer should be tested with a plumb line in order to ensure that the tube L is in a vertical position.

5.1.1 Those viscometers whose upper meniscus is offset from directly above the lower meniscus (all others in [Annex A1](#) and all in [Annex A3](#)) shall be mounted in a constant-temperature bath with tube L held within 0.3° of the vertical.

5.2 Round metal tops, designed to fit above a 51-mm hole in the lid of the bath, are frequently cemented on to the Zeitfuchs, Zeitfuchs cross-arm, and Lantz-Zeitfuchs viscometers which then are permanently mounted on the lid of the bath. Also a rectangular metal top, 25 mm × 59 mm, is often cemented on to the Zeitfuchs cross-arm and Zeitfuchs viscometers. Viscometers fitted with metal tops should also be set vertically in the constant-temperature bath with the aid of a plumb line.

5.3 In each figure, the numbers which follow the tube designation indicate the outside tube diameter in millimetres. It is important to maintain these diameters and the designated spacing to ensure that holders will be interchangeable.

## 6. Calibration of Viscometers

### 6.1 Procedures:

6.1.1 Calibrate the kinematic glass capillary viscometers covered by this standard using the procedures described in [Annex A1](#), [Annex A2](#), and [Annex A3](#).

### 6.2 Reference Viscometers:

6.2.1 Select a clear petroleum oil, free from solid particles and possessing Newtonian flow characteristics, with a kinematic viscosity within the range of both the reference viscometer and the viscometer to be calibrated. The minimum flow time shall be greater than that specified in the appropriate table of the annex in both the reference viscometer and the viscometer

which is to be calibrated in order that the kinetic energy correction (see [7.1](#) and [7.2](#)) may be less than 0.2 %.

6.2.2 Select a calibrated viscometer of known viscometer constant  $C_1$ . This viscometer may be a reference viscometer (driving head at least 400 mm) that has been calibrated by the step-up procedure using viscometers of successively larger capillary diameters, starting with distilled water as the basic kinematic viscosity standard or a routine viscometer of the same type that has been calibrated by comparison with a reference viscometer. See Test Method [D2162](#).

6.2.3 Mount the calibrated viscometer together with the viscometer to be calibrated in the same bath and determine the flow times of the oil in accordance with Test Method [D445](#).

6.2.3.1 The calibration of the reference viscometer should only be carried out by a reputable laboratory meeting the requirements of, for example, ISO Guide 25.

6.2.4 Calculate the viscometer constant  $C_1$  as follows:

$$C_1 = (t_2 \times C_2) / t_1 \quad (1)$$

where:

$C_1$  = the constant of the viscometer being calibrated,

$t_1$  = the flow time to the nearest 0.1 s in the viscometer being calibrated,

$C_2$  = the constant of the calibrated viscometer, and

$t_2$  = the flow time to the nearest 0.1 s in the calibrated viscometer.

6.2.5 Repeat [6.2.1](#) – [6.2.3](#) with a second oil whose flow times are at least 50 % longer than the first oil. If the two values of  $C_1$  differ by less than 0.2 % for those viscometers listed in [Annex A1](#) and [Annex A2](#) and less than 0.3 % for those viscometers listed in [Annex A3](#), use the average. If the constants differ by more than this value, repeat the procedure taking care to examine all possible sources of errors.

6.2.5.1 The calibration constant,  $C$ , is dependent upon the gravitational acceleration at the place of calibration and this must, therefore, be supplied by the standardization laboratory together with the instrument constant. Where the acceleration of gravity,  $g$ , differs by more than 0.1 %, correct the calibration constant as follows:

$$C_2 = (g_2 / g_1) \times C_1 \quad (2)$$

where subscripts 1 and 2 indicate respectively the standardization laboratory and the testing laboratory.

### 6.3 Certified Viscosity Reference Standards:

6.3.1 Certified viscosity reference standards shall be certified by a laboratory that has been shown to meet the requirements of ISO 17025 by independent assessment. Certified viscosity reference standards shall be traceable to master viscometer procedures described in Practice [D2162](#).

6.3.1.1 The uncertainty of the certified viscosity reference standard shall be stated for each certified value ( $k=2$ , 95% confidence). See ISO 5725 or NIST 1297.

6.3.2 Select from [Table 1](#) a certified viscosity reference standard with a kinematic viscosity at the calibration temperature within the kinematic viscosity range of the viscometer to be calibrated and a minimum flow time greater than that specified in the appropriate table of the annex. Determine the

**TABLE 1 Certified Viscosity Reference Standards**

Designation	Approximate Kinematic Viscosity, mm <sup>2</sup> /s					
	20°C	25°C	40°C	50°C	80°C	100°C
S3	4.6	4.0	2.9	...	...	1.2
S6	11	8.9	5.7	...	...	1.8
S20	44	34	18	...	...	3.9
S60	170	120	54	...	...	7.2
S200	640	450	180	...	...	17
S600	2400	1600	520	280	67	32
S2000	8700	5600	1700	...	...	75
S8000	37 000	23 000	6700	...	...	...
S30000	...	81 000	23 000	11 000	...	...

flow time to the nearest 0.1 s in accordance with Test Method **D445** and calculate the viscometer constant,  $C$ , as follows:

$$C = v/t \quad (3)$$

where:

- $v$  = the kinematic viscosity, mm<sup>2</sup>/s, for the certified viscosity reference standard, and
- $t$  = the flow time, s.

6.3.3 Repeat with a second certified viscosity reference standard whose flow times are at least 50 % longer than the first certified viscosity reference standard. If the two values of  $C$  differ by less than 0.2 % for those viscometers listed in **Annex A1** and **Annex A2** and less than 0.3 % for those viscometers listed in **Annex A3**, use the average as the viscometer constant for the viscometer being calibrated. If the constants differ by more than this value, repeat the procedure taking care to examine all possible sources of errors.

#### 6.4 Expression of Constant:

6.4.1 Report the constant to the nearest 0.1 % of the determined value. This generally means four significant figures from  $1 \times 10^N$  to  $6.999 \times 10^N$  and three significant figures from  $7 \times 10^N$  to  $9.99 \times 10^N$ .

## 7. Kinematic Viscosity Calculation

### 7.1 Basic Formula:

7.1.1 Kinematic viscosity, expressed in mm<sup>2</sup>/s, can be calculated from the viscometer dimensions as follows:

$$v = (10^6 \pi g D^4 H t / 128 V L) - E/t^2 \quad (4)$$

where:

- $v$  = the kinematic viscosity, mm<sup>2</sup>/s,
- $g$  = the acceleration due to gravity, m/s<sup>2</sup>,
- $D$  = the diameter of the capillary, m,
- $L$  = the length of the capillary, m,
- $H$  = the average distance between the upper and lower menisci, m,
- $V$  = the timed volume of liquids passing through the capillary, m<sup>3</sup> (approximately the volume of the timing bulb),
- $E$  = the kinetic energy factor, mm<sup>2</sup>·s, and
- $t$  = the flow time, s.

7.1.2 If the viscometer is selected so that the minimum flow time shown in the tables of **Annex A1**, **Annex A2**, and **Annex A3** are exceeded, the kinetic energy term,  $E/t^2$ , becomes insignificant and Eq 4 may be simplified by grouping the non-variable terms into a constant,  $C$ , as follows:

$$v = C \cdot t \quad (5)$$

### 7.2 Kinetic Energy Correction:

7.2.1 The viscometers described in the **Annex A1**, **Annex A2**, and **Annex A3** are designed such that the kinetic energy correction term,  $E/t^2$ , is negligible if the flow time is more than 200 s. In the case of several sizes of viscometers for the measurement of low-kinematic viscosity liquids, a minimum flow time greater than 200 s is required in order that the kinetic energy correction term,  $E/t^2$ , shall be negligible. The minimum flow times required are set out as footnotes to the appropriate tables of viscometer dimensions given in the **Annex A1**, **Annex A2**, and **Annex A3**.

7.2.2 For viscometers whose constants are 0.05 mm<sup>2</sup>/s<sup>2</sup> or less, a kinetic energy correction can be significant if the minimum 200 s flow is not observed. Where this is not possible, Eq 5 takes on the following form:

$$\text{kinematic viscosity, mm}^2/\text{s} = Ct - E/t^2 \quad (6)$$

where:

- $E$  = kinetic energy factor, mm<sup>2</sup> × s,
- $C$  = viscometer constant, mm<sup>2</sup>/s<sup>2</sup>,
- $t$  = flow time, s.

7.2.3 Although the kinetic energy factor,  $E$ , is not a constant, it may be approximated by means of the following equation:

$$E = 52.5 V^{3/2} / L (Cd)^{1/2} \quad (7)$$

where:

(using the units given in **Figs. A1.1-A3.4**)

- $V$  = volume of the timing bulb, mL,
- $L$  = capillary working length, mm,
- $d$  = capillary working diameter, mm,
- $C$  = viscometer constant, mm<sup>2</sup>/s<sup>2</sup>.

NOTE 1—The kinetic energy factor for certain viscometer designs and flow time use can result in significant kinematic viscosity errors. Determine the effect of the kinetic energy factor for viscometers not described in this specification.

### 7.3 Maximum Flow Time:

7.3.1 The limit of 1000 s has been set arbitrarily for convenience as the recommended maximum flow time for the viscometers covered by this standard. Longer flow times may be used.

### 7.4 Surface Tension Correction :

7.4.1 If the two menisci have different average diameters during the flow time and if the surface tension of the sample differs substantially from the calibrating liquid, a surface

tension correction is necessary. The changed  $C$  constant,  $C_2$ , is given approximately as follows:

$$C_2 = C_1 [1 + (2/g h)(1/r_u - 1/r_l) \cdot (\gamma_1/\rho_1 - \gamma_2/\rho_2)] \quad (8)$$

where:

- $g$  = the acceleration due to gravity,  $m/s^2$ ,
- $h$  = the average driving head, m,
- $r_u$  = the average radius of the upper meniscus, m,
- $r_l$  = the average radius of the lower meniscus, m,
- $\gamma$  = the surface tension, N/m, and
- $\rho$  = the density, in  $kg/m^3$ .

Subscripts 1 and 2 relate to values with the calibrating liquid and the test portion, respectively.

7.4.2 While this correction applies to all viscometers, a number of viscometers are designed to minimize the surface tension correction. The greatest correction normally encountered is with a viscometer calibrated with water and used for oils. Generally, viscometers are calibrated and used with hydrocarbons whose surface tensions are close enough for these corrections to be insignificant.

#### 7.5 Effect of Temperature:

7.5.1 The viscometer constant,  $C$ , is independent of temperature for all those viscometers which have the volume of sample adjusted at bath temperature and in the case of all suspended-level viscometers.

7.5.2 The following viscometers, which have a fixed volume charged at ambient temperature, have a viscometer constant,  $C$ , which varies with temperature: Cannon-Fenske routine, Pinkevitch, Cannon-Manning semi-micro, Cannon-Fenske opaque.

7.5.3 The following equation can be used to calculate the viscometer constant at temperatures other than the calibration temperature for the Cannon-Fenske routine, Pinkevitch, and Cannon-Manning semi-micro viscometers:

$$C_2 = C_1 [1 + (4000 V(\rho_2 - \rho_1)) / (\pi D^2 h \rho_2)] \quad (9)$$

where:

- $C_1$  = the constant of the viscometer when filled and calibrated at the same temperature,
- $V$  = the volume of charge, mL,
- $D$  = the average diameter of the meniscus in the lower reservoir for the Cannon-Fenske routine, Pinkevitch, and Cannon-Manning semi-micro viscometers, and in the upper reservoir of the Cannon-Fenske opaque viscometer, mm,
- $h$  = the average driving head, mm,
- $\rho_1$  = the density of the test liquid at the filling temperature,  $kg/m^3 \times 10^{-3}$ , and
- $\rho_2$  = the density of the test liquid at the test temperature,  $kg/m^3 \times 10^{-3}$ .

7.5.4 The temperature dependence of  $C$  for the Cannon-Fenske opaque (reverse-flow) viscometer is given as follows:

$$C_2 = C_1 [1 - (4000 V(\rho_2 - \rho_1)) / (\pi D^2 h \rho_2)] \quad (10)$$

## 8. Keywords

8.1 kinematic viscosity; viscometer; viscosity

## ANNEXES

### (Mandatory Information)

## A1. MODIFIED OSTWALD VISCOMETERS

### A1.1 General

A1.1.1 The following viscometers of the modified Ostwald type for transparent liquids follow the basic design of the Ostwald viscometer, but are modified to ensure a constant volume test portion in the viscometer as described in A1.1.2 and A1.1.3.

A1.1.2 These viscometers are used for the measurement of the kinematic viscosity of transparent Newtonian liquids up to 20 000  $mm^2/s$ .

A1.1.3 For the modified Ostwald viscometers, detailed drawings, size designations, nominal constants, kinematic viscosity range, capillary diameter, and bulb volumes for each viscometer are shown in Figs. A1.1-A1.7.

A1.1.3.1 Constant volume at filling temperature:

- (1) Cannon-Fenske routine viscometer
- (2) Cannon-Manning semi-micro viscometer

(3) Pinkevitch viscometer

A1.1.3.2 Constant volume at the test temperature:

- (1) Zeitfuchs viscometer<sup>5</sup>
- (2) SIL viscometer
- (3) BS/U-tube viscometer
- (4) BS/U-tube miniature viscometer

### A1.2 Operating Instructions

A1.2.1 A standard operating procedure applicable to all glass capillary kinematic viscometers is contained in Test Method D445. Operating instructions for the modified Ostwald viscometers are outlined in A1.2.2 – A1.2.7 with emphasis on procedures that are specific to this group of viscometers.

NOTE A1.1—ISO methods 3104 and 3105 correspond to Test Methods

<sup>5</sup> Zeitfuchs is a tradename of Cannon Instrument Co., P. O. Box 16, State College, PA 16804-0016.

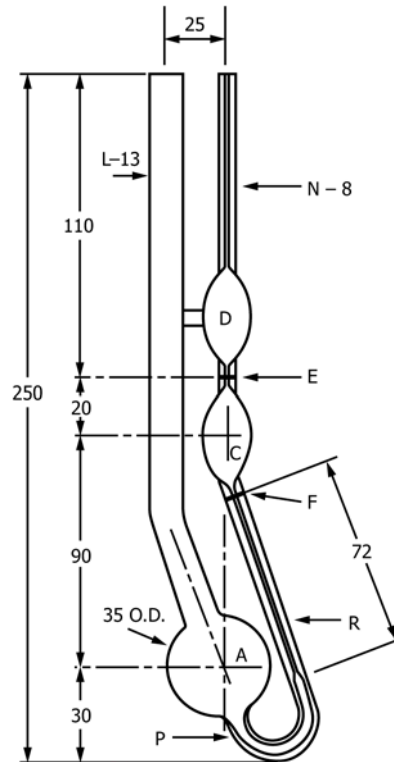

NOTE 1—All dimensions are in millimetres.

NOTE 2—For size 25 only, the capillary *N* extends straight through bulbs *D* and *C* to about 10 mm below bulb *C*; the timing mark *F* encircles this capillary.

Size No.	Approximate Constant, (mm <sup>2</sup> /s)/s	Kinematic Viscosity Range, mm <sup>2</sup> /s	Inside Diameter of Tube <i>R</i> , mm (±2%)	Inside Diameter of Tubes <i>N</i> , <i>E</i> , and <i>P</i> , mm	Bulb Volume, mL (±5%)	
					<i>D</i>	<i>C</i>
25	0.002	0.5 <sup>A</sup> to 2	0.30	2.6 to 3.0	3.1	1.6
50	0.004	0.8 to 4	0.44	2.6 to 3.0	3.1	3.1
75	0.008	1.6 to 8	0.54	2.6 to 3.2	3.1	3.1
100	0.015	3 to 15	0.63	2.8 to 3.6	3.1	3.1
150	0.035	7 to 35	0.78	2.8 to 3.6	3.1	3.1
200	0.1	20 to 100	1.01	2.8 to 3.6	3.1	3.1
300	0.25	50 to 250	1.27	2.8 to 3.6	3.1	3.1
350	0.5	100 to 500	1.52	3.0 to 3.8	3.1	3.1
400	1.2	240 to 1200	1.92	3.0 to 3.8	3.1	3.1
450	2.5	500 to 2500	2.35	3.5 to 4.2	3.1	3.1
500	8	1600 to 8000	3.20	3.7 to 4.2	3.1	3.1
600	20	4000 to 20 000	4.20	4.4 to 5.0	4.3	3.1

<sup>A</sup> 250-s minimum flow time; 200-s minimum flow time for all other units.

FIG. A1.1 Cannon-Fenske Routine Viscometer for Transparent Liquids

D445 and D446, respectively.

A1.2.2 Select a clean, dry calibrated viscometer which will give a flow-time greater than 200 s or the minimum shown in the table of dimensions, whichever is greater.

A1.2.3 Charge the viscometer in the manner dictated by the design of the instrument, the operation being in conformity with that employed when the unit was calibrated. If the sample is thought or known to contain fibers or solid particles, filter through a 75- $\mu$ m screen either prior to or during charging.

NOTE A1.2.—To minimize the potential of particles passing through the filter from aggregating, it is recommended that the time lapse between

filtering and charging be kept to a minimum.

A1.2.3.1 To charge the Cannon-Fenske routine, Cannon-Manning semi-micro, and Pinkevitch viscometers, invert the viscometer and apply suction to tube *L* (the Pinkevitch viscometer has a side arm *O* to which vacuum is applied, with the finger on tube *L* being used to control the liquid flow) with tube *N* immersed in the liquid sample. Draw the sample to timing mark *F* for the Cannon-Fenske routine and Pinkevitch viscometers and to filling mark *G* for the Cannon-Manning semi-micro viscometer. Mount the viscometer upright in the constant-temperature bath keeping tube *L* vertical.

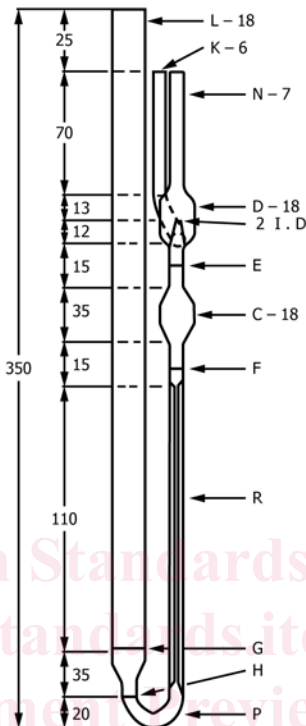
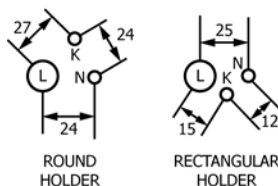

NOTE 1—All dimensions are in millimetres.

Size No.	Approximate Constant, (mm <sup>2</sup> /s)/s	Kinematic Viscosity Range, <sup>A</sup> mm <sup>2</sup> /s	Inside Diameter of Tube R, mm (±2 %)	Inside Diameter of Tubes P, E, and F, mm	Volume, Bulb C, mL (±5 %)
1	0.003	0.6 to 3	0.42	3.8 to 4.2	3.0
2	0.01	2 to 10	0.59	3.8 to 4.2	4.0
3	0.03	6 to 30	0.78	3.8 to 4.2	4.0
4	0.1	20 to 100	1.16	3.8 to 4.2	5.0
5	0.3	60 to 300	1.54	3.8 to 4.2	5.0
6	1.0	200 to 1000	2.08	3.8 to 4.2	5.0
7	3.0	600 to 3000	2.76	3.8 to 4.2	5.0

<sup>A</sup> 200-s minimum flow time for all units.

FIG. A1.2 Zeitfuchs Viscometer for Transparent Liquids

A1.2.3.2 Mount the Zeitfuchs viscometer in the constant-temperature bath, keeping tube L vertical. Pour sample through tube L to fill mark G. Allow 15 min for the sample to attain bath temperature and become free of air bubbles. Attach the vacuum line with stopcock and trap to tube K. Slowly draw the sample into timing bulb C by partially opening the stopcock in the vacuum line and partially closing tube N with the finger. Allow the excess liquid to flow into bulb D and through tube K into the trap in the vacuum line. When the liquid in tube L reaches a point 2 mm to 5 mm above filling mark H, hold it at this point by alternately closing the opening tube N to the atmosphere with the finger for the time in the Table A1.1 shown as follows to permit the sample to drain from the walls of tube L.

(1) Adjust the working volume by drawing the meniscus at the bottom of the column of the liquid exactly to filling mark H, making sure that the sample completely fills the viscometer between mark H and the tip of the overflow in bulb D; after this final adjustment of the working volume, remove the finger and close or remove the connection to the vacuum source. The final adjustment may be more conveniently made by disconnecting the vacuum and applying pressure to the mounting tube L by use of a rubber bulb.

A1.2.3.3 Charge the SIL viscometer by tilting it about 30° from the vertical, with bulb A below capillary R. Introduce enough of the sample into tube L for bulb A to fill completely and overflow into the gallery. Return the viscometer to the vertical position and mount it in the constant-temperature bath

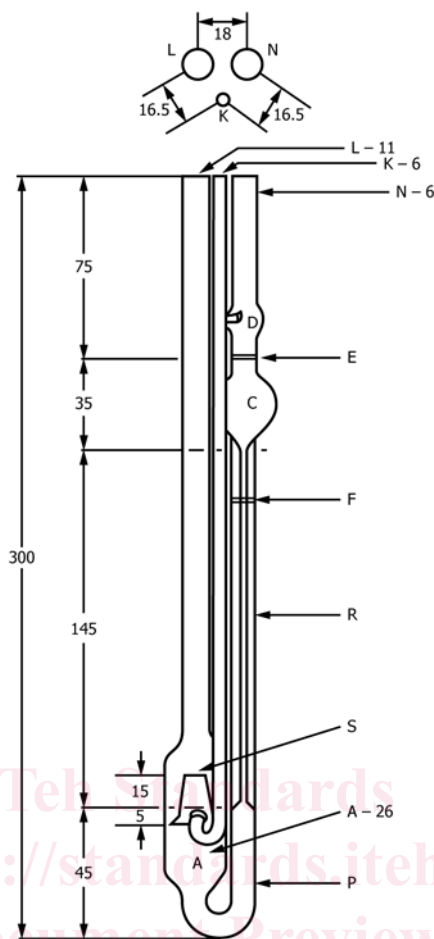

NOTE 1—All dimensions are in millimetres.

Size No.	Approximate Constant, (mm <sup>2</sup> /s)/s	Kinematic Viscosity Range, <sup>A</sup> mm <sup>2</sup> /s	Inside Diameter of Tube R, mm (±2%)	Inside Diameter of Tubes E and P, mm	Volume, Bulb C, mL (±5%)
0C	0.003	0.6 to 3	0.41	4.5 to 5.5	3.0
1	0.01	2.0 to 10	0.61	4.5 to 5.5	4.0
1C	0.03	6 to 30	0.79	4.5 to 5.5	4.0
2	0.1	20 to 100	1.14	4.5 to 5.5	5.0
2C	0.3	60 to 300	1.50	4.5 to 5.5	5.0
3	1.0	200 to 1000	2.03	4.5 to 5.5	5.0
3C	3.0	600 to 3000	2.68	4.5 to 5.5	5.0
4	10.0	2000 to 10 000	3.61	4.5 to 5.5	5.0

<sup>A</sup> 200-s minimum flow time for all units.

FIG. A1.3 SIL Viscometer for Transparent Liquids

so that tube L is vertical. The quantity of sample charged should be such that the level in the lower reservoir is 3 mm to 14 mm above opening S. The sample will rise in capillary R somewhat higher than opening S. After the temperature equilibrium has been reached, remove any excess sample from the gallery by suction applied to tube K.

A1.2.3.4 Mount the BS/U-tube or BS/U/M miniature viscometer in the constant-temperature bath keeping the tube L vertical. Using a long pipette to minimize any wetting of tube L above filling mark G, fill bulb A with a slight excess of the sample. After allowing the sample to attain the bath temperature, adjust the volume of the sample to bring the liquid level within 0.2 mm of filling mark G by withdrawing the sample with a pipette.

A1.2.4 Allow the charged viscometer to remain in the bath long enough to reach the test temperature. Because this time will vary for different instruments, for different temperatures, and for different kinematic viscosities, establish a safe equilibrium time by trial (30 min should be sufficient except for the highest kinematic viscosities). One bath is often used to accommodate several viscometers. Never add or withdraw a viscometer while any other viscometer is in use for measuring a flow time.

A1.2.5 Use vacuum (or pressure if the sample contains volatile constituents) to draw the sample through bulb C to about 5 mm above upper timing mark E. Release the vacuum, and allow the sample to flow by gravity.

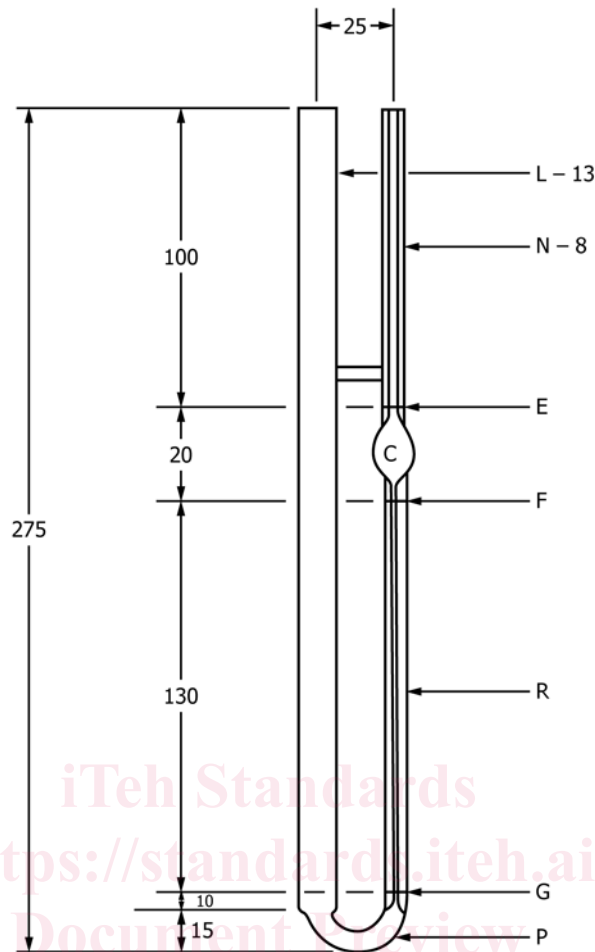

NOTE 1—All dimensions are in millimetres.

Size No.	Approximate Constant, (mm <sup>2</sup> /s)/s	Kinematic Viscosity Range, <sup>A</sup> mm <sup>2</sup> /s	Inside Diameter of Tube	Inside Diameter of Tubes		Volume, Bulb C, mL (±5 %)
			R, mm (±2 %)	N and F, mm	P, mm	
25	0.002	0.4 to 2.0	0.22 ± 0.01	1.0 to 1.2	0.4 to 0.7	0.31
50	0.004	0.8 to 4	0.26 ± 0.01	1.0 to 1.2	0.5 to 0.8	0.31
75	0.008	1.6 to 8	0.31 ± 0.01	1.1 to 1.3	0.6 to 0.8	0.31
100	0.015	3 to 15	0.36 ± 0.02	1.2 to 1.4	0.7 to 0.9	0.31
150	0.035	7 to 35	0.47 ± 0.02	1.2 to 1.4	0.8 to 1.0	0.31
200	0.1	20 to 100	0.61 ± 0.02	1.4 to 1.7	0.9 to 1.2	0.31
300	0.25	50 to 250	0.76 ± 0.02	1.5 to 1.8	1.2 to 1.6	0.31
350	0.5	100 to 500	0.90 ± 0.03	1.8 to 2.2	1.5 to 1.8	0.31
400	1.2	240 to 1200	1.13 ± 0.03	2.0 to 2.4	1.6 to 2.0	0.31
450	2.5	500 to 2500	1.40 ± 0.04	2.2 to 2.6	2.0 to 2.5	0.31
500	8	1600 to 8000	1.85 ± 0.05	2.4 to 2.8	2.5 to 2.8	0.31
600	20	4000 to 20 000	2.35 ± 0.05	3.0 to 3.4	2.7 to 3.0	0.31

<sup>A</sup> 200-s minimum flow time for all units.

FIG. A1.4 Cannon-Manning Semi-Micro Viscometer for Transparent Liquids

A1.2.6 Measure, to the nearest 0.1 s, the time required for the leading edge of the meniscus to pass from timing mark E to timing mark F. If this flow time is less than the minimum flow time specified for the viscometer, select a viscometer with a smaller diameter capillary and repeat steps A1.2.3 – A1.2.6.

A1.2.7 Repeat steps A1.2.5 to A1.2.6 making a duplicate measurement of flow time. If the two measurements agree within the determinability given in Test Method D445 for the product being measured, use the average for calculating kinematic viscosity.

A1.2.8 Clean the viscometer thoroughly by several rinsings with an appropriate solvent completely miscible with the sample, followed by rinsing with a completely volatile solvent. Dry the viscometer by passing a slow stream of filtered, dry air through the viscometer for 2 min, or until the last trace of solvent is removed. The use of alkaline cleaning solutions is not recommended as changes in the viscometer calibration may occur.



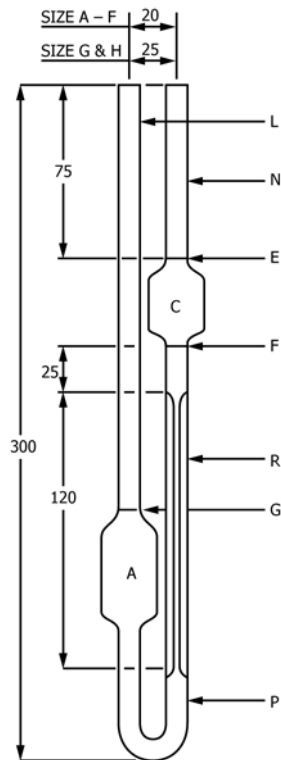

NOTE 1—All dimensions are in millimetres.

Size No.	Nominal Viscometer Constant, (mm <sup>2</sup> /s)/s	Kinematic Viscosity Range, mm <sup>2</sup> /s	Inside Diameter of Tube R, mm (±2 %)	Outside Diameter of Tubes <sup>A</sup>		Volume Bulb C, mL (±5 %)	Vertical Distance F to G, mm	Outside Diameter of Bulbs A and C, mm
				L and P, mm	N, mm			
A	0.003	0.9 <sup>B</sup> to 3	0.50	8 to 9	6 to 7	5.0	91 ± 4	21 to 23
B	0.01	2.0 to 10	0.71	8 to 9	6 to 7	5.0	87 ± 4	21 to 23
C	0.03	6 to 30	0.88	8 to 9	6 to 7	5.0	83 ± 4	21 to 23
D	0.1	20 to 100	1.40	9 to 10	7 to 8	10.0	78 ± 4	25 to 27
E	0.3	60 to 300	2.00	9 to 10	7 to 8	10.0	73 ± 4	25 to 27
F	1.0	200 to 1000	2.50	9 to 10	7 to 8	10.0	70 ± 4	25 to 27
G	3.0	600 to 3000	4.00	10 to 11	9 to 10	20.0	60 ± 3	32 to 35
H	10.0	2000 to 10 000	6.10	10 to 11	9 to 10	20.0	50 ± 3	32 to 35

<sup>A</sup> Use 1 to 1.25 mm wall tubing for N, P, and L.

<sup>B</sup> 300 s minimum flow time; 200 s minimum flow time for all other sizes.

FIG. A1.5 BS/U-Tube Viscometer for Transparent Liquids

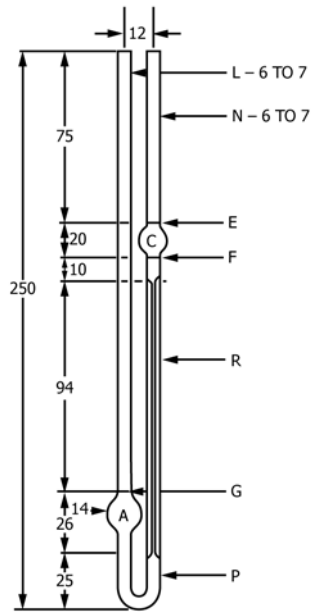

NOTE 1—All dimensions are in millimetres.

Size No.	Nominal Viscometer Constant, (mm <sup>2</sup> /s)/s	Kinematic Viscosity Range, <sup>A</sup> mm <sup>2</sup> /s	Inside Diameter of Tube R, mm (±2 %)	Outside Diameter of Tubes L, N, and P <sup>B</sup> , mm	Volume Bulb C, mL (±5 %)
M1	0.001	0.2 to 1	0.20	6 to 7	0.50
M2	0.005	1 to 5	0.30	6 to 7	0.50
M3	0.015	3 to 15	0.40	6 to 7	0.50
M4	0.04	8 to 40	0.50	6 to 7	0.50
M5	0.1	20 to 100	0.65	6 to 7	0.50

<sup>A</sup> 200 s minimum flow time for all sizes.

<sup>B</sup> Use 1 to 1.25 mm wall tubing for N, P, and L.

FIG. A1.6 BS/U/M Miniature Viscometer for Transparent Liquids

ASTM D446-12

<https://standards.iteh.ai/catalog/standards/sist/822e4182-f16a-4f7b-af04-7af5edd6ae53/astm-d446-12>