



Designation: D1160 – 12

## Standard Test Method for Distillation of Petroleum Products at Reduced Pressure<sup>1</sup>

This standard is issued under the fixed designation D1160; the number immediately following the designation indicates the year of original adoption or, in the case of revision, the year of last revision. A number in parentheses indicates the year of last reapproval. A superscript epsilon ( $\epsilon$ ) indicates an editorial change since the last revision or reapproval.

*This standard has been approved for use by agencies of the Department of Defense.*

### 1. Scope\*

1.1 This test method covers the determination, at reduced pressures, of the range of boiling points for petroleum products that can be partially or completely vaporized at a maximum liquid temperature of 400°C. Both a manual method and an automatic method are specified.

1.2 In cases of dispute, the referee test method is the manual test method at a mutually agreed upon pressure.

1.3 The values stated in SI units are to be regarded as the standard. The values in parentheses are for information only.

1.4 *This standard does not purport to address all of the safety concerns, if any, associated with its use. It is the responsibility of the user of this standard to establish appropriate safety and health practices and determine the applicability of regulatory limitations prior to use.* For specific warning statements, see 6.1.4, 6.1.8.1, 10.11, and A3.2.1.

### 2. Referenced Documents

2.1 *ASTM Standards:*<sup>2</sup>

D613 Test Method for Cetane Number of Diesel Fuel Oil

D1193 Specification for Reagent Water

D1250 Guide for Use of the Petroleum Measurement Tables

D1298 Test Method for Density, Relative Density, or API Gravity of Crude Petroleum and Liquid Petroleum Products by Hydrometer Method

D4052 Test Method for Density, Relative Density, and API Gravity of Liquids by Digital Density Meter

D4057 Practice for Manual Sampling of Petroleum and Petroleum Products

D4177 Practice for Automatic Sampling of Petroleum and Petroleum Products

<sup>1</sup> This test method is under the jurisdiction of ASTM Committee D02 on Petroleum Products and Lubricants and is the direct responsibility of Subcommittee D02.08 on Volatility.

Current edition approved Dec. 1, 2012. Published March 2013. Originally approved in 1951. Last previous edition approved in 2006 as D1160-06. DOI: 10.1520/D1160-12.

<sup>2</sup> For referenced ASTM standards, visit the ASTM website, [www.astm.org](http://www.astm.org), or contact ASTM Customer Service at [service@astm.org](mailto:service@astm.org). For *Annual Book of ASTM Standards* volume information, refer to the standard's Document Summary page on the ASTM website.

### 3. Terminology

3.1 *Definitions of Terms Specific to This Standard:*

3.1.1 *atmospheric equivalent temperature (AET), n*—the temperature converted from the measured vapor temperature using Eq A7.1. The AET is the expected distillate temperature if the distillation was performed at atmospheric pressure and there was no thermal decomposition.

3.1.2 *end point (EP) or final boiling point (FBP), n*—the maximum vapor temperature reached during the test.

3.1.3 *initial boiling point (IBP), n*—the vapor temperature that is measured at the instant the first drop of condensate falls from the lower end of the condenser section drip tip.

3.1.3.1 *Discussion*—When a chain is attached to the drip tip the first drop will form and run down the chain. In automatic apparatus, the first drop detection device shall be located as near to the lower end of the drip tip as practical.

3.1.4 *spillover point, n*—the highest point of the lower internal junction of the distillation column and the condensing section of the vacuum-jacketed column assembly.

### 4. Summary of Test Method

4.1 The sample is distilled at an accurately controlled pressure between 0.13 and 6.7 kPa (1 and 50 mm Hg) under conditions that are designed to provide approximately one theoretical plate fractionation. Data are obtained from which the initial boiling point, the final boiling point, and a distillation curve relating volume percent distilled and atmospheric equivalent boiling point temperature can be prepared.

### 5. Significance and Use

5.1 This test method is used for the determination of the distillation characteristics of petroleum products and fractions that may decompose if distilled at atmospheric pressure. This boiling range, obtained at conditions designed to obtain approximately one theoretical plate fractionation, can be used in engineering calculations to design distillation equipment, to prepare appropriate blends for industrial purposes, to determine compliance with regulatory rules, to determine the suitability of the product as feed to a refining process, or for a host of other purposes.

\*A Summary of Changes section appears at the end of this standard

5.2 The boiling range is directly related to viscosity, vapor pressure, heating value, average molecular weight, and many other chemical, physical, and mechanical properties. Any of these properties can be the determining factor in the suitability of the product in its intended application.

5.3 Petroleum product specifications often include distillation limits based on data by this test method.

5.4 Many engineering design correlations have been developed on data by this test method. These correlative methods are used extensively in current engineering practice.

## 6. Apparatus

6.1 The vacuum distillation apparatus, shown schematically in Fig. 1, consists in part of the components described below plus others that appear in Fig. 1 but are not specified, either as to design or performance. Some of these parts are not essential for obtaining satisfactory results from the tests but are desirable components of the assembly for the purpose of promoting the efficient use of the apparatus and ease of its operation. Both manual and automatic versions of the apparatus must conform to the following requirements. Additional requirements for the automatic apparatus can be found in Annex A9.

6.1.1 *Distillation Flask*, of 500-mL capacity, made of borosilicate glass or of quartz conforming to the dimensions given in Fig. 2 or Fig. 3, and having a heating mantle with insulating top. These dimensions can vary slightly by manufacturer, and are not considered critical dimensions, with the exception of the position of the end of the temperature sensing probe, and the inner diameter of the connection to the distillation column not being less than the inner diameter of the distillation

column. The use of the thermowell can be replaced by an encased temperature probe and the second side neck is present on commercially available flasks used in this test method.

6.1.2 *Vacuum-Jacketed Column Assembly*, of borosilicate glass, consisting of a distilling head and an associated condenser section as illustrated in the lettered drawing, Fig. 4 and Table 1. The head shall be enclosed in a completely silvered glass vacuum jacket with a permanent vacuum of less than  $10^{-5}$  Pa ( $10^{-7}$  mm Hg) (Note 1). The attached condenser section shall be enclosed in water jackets as illustrated and have an adapter at the top for connection to the vacuum source. A light drip-chain shall hang from the drip tip of the condenser to a point 5 mm below the 10-mL mark of the receiver as shown in Fig. 5. Alternatively, instead of the metal drip-chain, a metal trough may be used to channel the distillate to the wall of the receiver. This trough may either be attached to the condenser drip tip as shown in Fig. 5 or it may also be located in the neck of the receiver.

NOTE 1—There is no simple method to determine the vacuum in the jacket once it is completely sealed. A Tesla coil can be used, but the spark can actually create a pinhole in a weak spot in the jacket. Even the slightest pinhole or crack not readily detectable by sight alone will negate the vacuum in the jacket.

6.1.3 *Vapor Temperature Measuring Device* and associated signal conditioning and processing instruments (Annex A1) for the measurement of the vapor temperature. The system must produce readings with an accuracy of  $\pm 0.5^\circ\text{C}$  over the range 0 to  $400^\circ\text{C}$  and have a response time of less than 200 s as described in Annex A2. The location of the vapor temperature

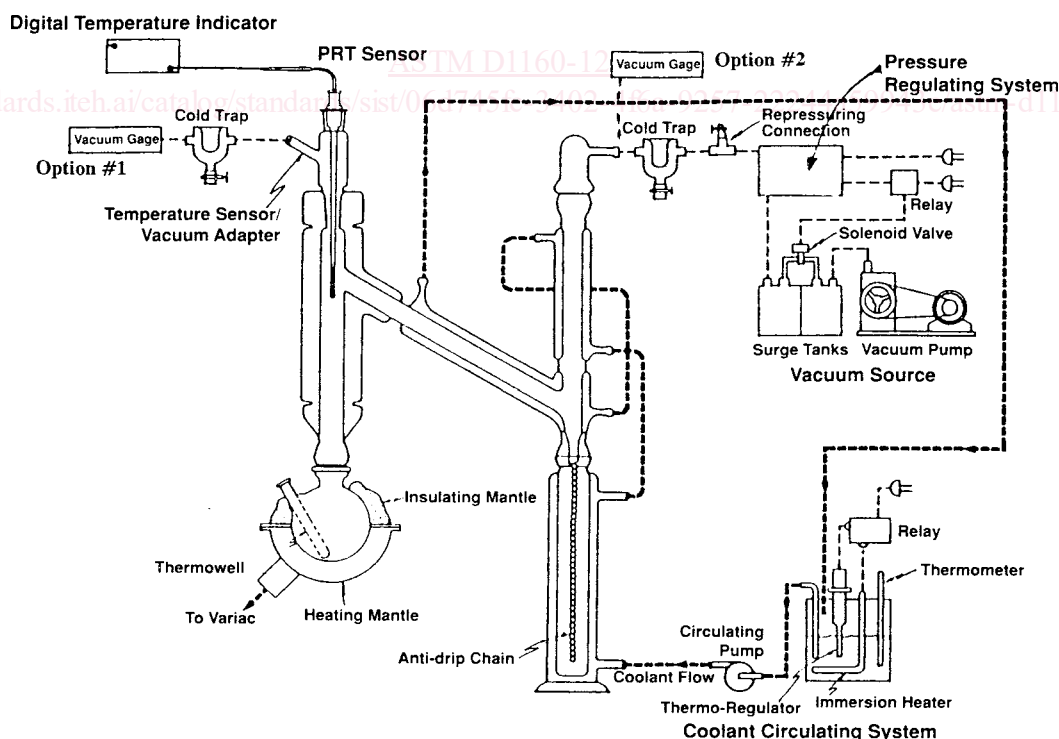

NOTE 1—A cold trap can be inserted before the pressure transducer in Option No. 2, if desired, or if the design of the transducer, such as a mercury McCleod gage, would require vapor protection.

FIG. 1 Assembly of Vacuum Distillation Apparatus

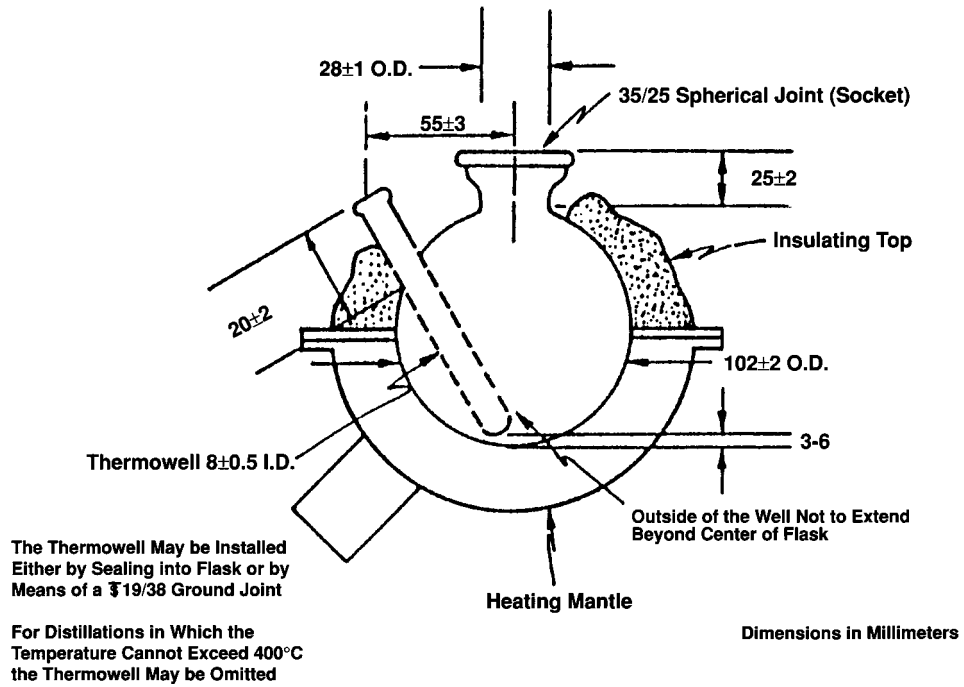

FIG. 2 Distillation Flask and Heating Mantle

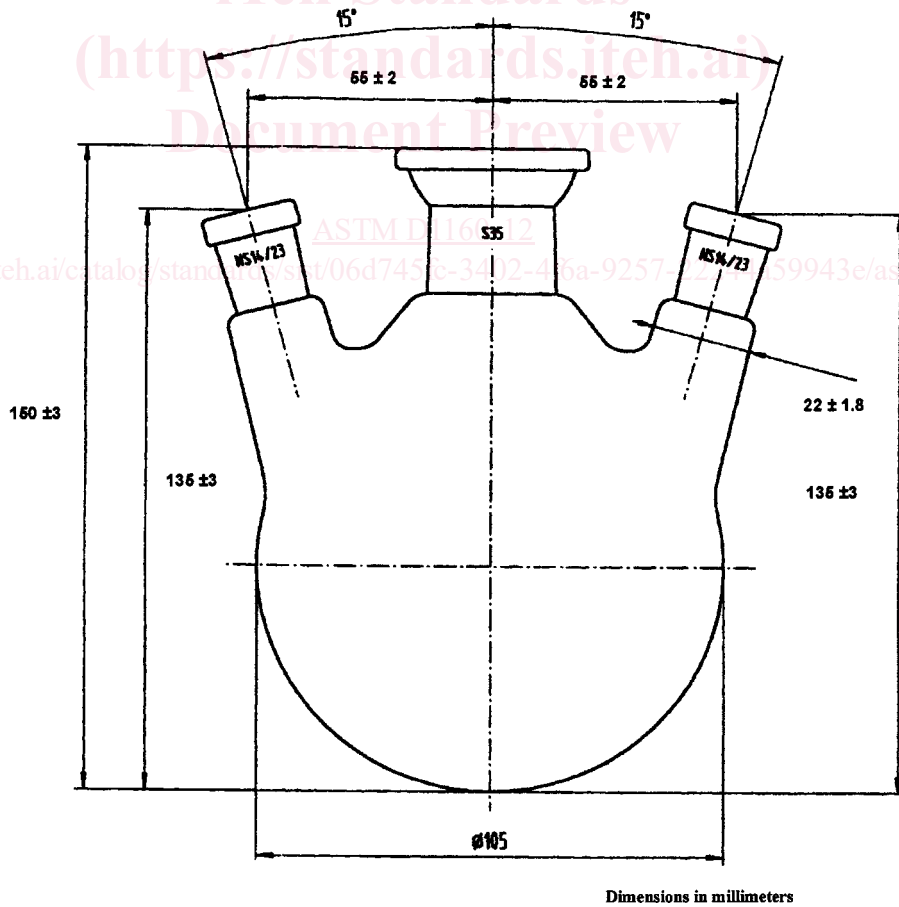

FIG. 3 Distillation Flask 500 ML

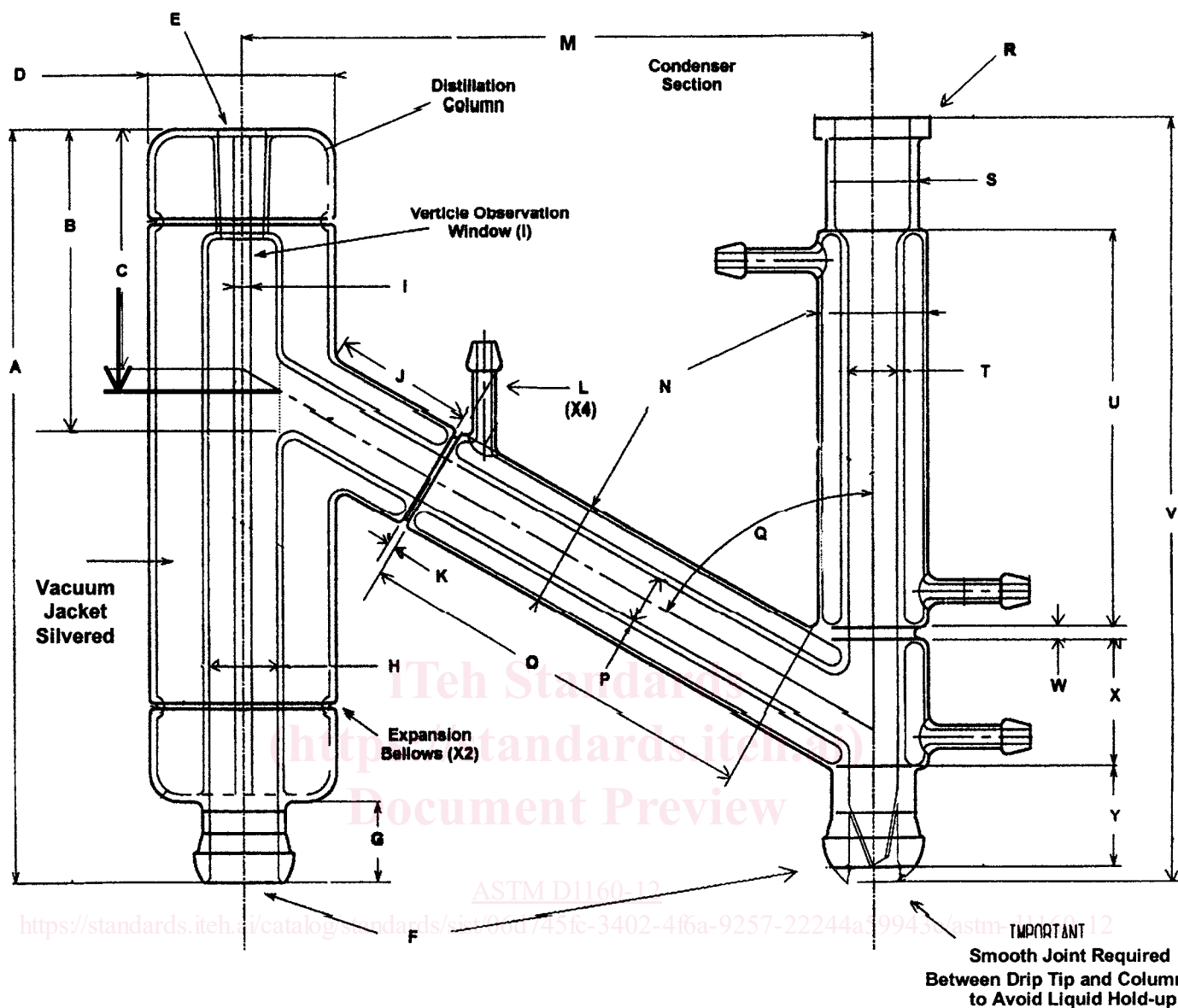

FIG. 4 Vacuum-Jacketed Column

sensor is extremely critical. As shown in Fig. 6, the vapor temperature measuring device shall be centered in the upper portion of the distillation column with the top of the sensing tip  $3 \pm 1$  mm below the spillover point (see 3.1). The vapor temperature measuring device can consist of different configurations depending if it is a platinum resistance in glass or metal, or if it is a thermocouple in glass or metal. Figs. 7 and 8 show the proper positioning of these two types in relation to the spillover point. In glass platinum resistance devices the top of the spiral winding is the top of the sensing tip, in thermocouples it is the top of the thermocouple junction, in metal jacketed devices it is  $1 \pm 1$  mm above the bottom of the device. An alignment procedure is described in Appendix X1. The vapor temperature measuring device shall be mounted through a compression ring type seal mounted on the top of the glass temperature sensor/vacuum adapter or fused into a ground taper joint matched to the distillation column. In some distillation apparatus configurations, the vacuum adapter at the top

of the distillation column can be omitted. In these cases, the position of the vapor temperature measuring device shall be adjusted accordingly. The boiler temperature measuring device may be either a thermocouple or PRT and shall also be calibrated as above.

6.1.4 *Receiver* of borosilicate glass, conforming to the dimensions shown in Fig. 9. If the receiver is part of an automatic unit and is mounted in a thermostatted chamber, the jacket is not required. (**Warning**—The glass parts of the apparatus are subjected to severe thermal conditions and, to lessen the chances of failure during a test, only equipment shown to be strain-free under polarized light should be used.)

6.1.5 *Vacuum Gage*, capable of measuring absolute pressures with an accuracy of 0.01 kPa in the range below 1 kPa absolute and with an accuracy of 1 % above this pressure. The McLeod gage can achieve this accuracy when properly used, but a mercury manometer will permit this accuracy only down to a pressure of about 1 kPa and then only when read with a

TABLE 1 Vacuum-Jacketed Column Assembly Dimensions

NOTE 1—These dimensions are for guidance for verifying the appropriate construction of the assembly. The actual dimensions used by glassmakers vary to some extent, and the dimensions they use to construct the assembly are not easily obtained after the assembly is fused together. Those dimensions noted as critical shall be adhered to within the tolerance listed. The dimensions listed in this chart have been gathered from users of the various manufactured manual and automatic apparatus who participated in the interlaboratory program to produce the precision for this test method.

NOTE 2—**Important**—Further study will progress to produce a set of dimensions which will be more restrictive in range of dimension, since it is believed that the current wide variance in dimensions has resulted in precision for this test method to be significantly high. The target dimensions for this assembly and other components of the apparatus are expected to be available within the next year, with implementation expected to occur after five years of initial revised test method publication date.

Component	Critical	Dimensions <sup>A</sup>	Notes
A	no	265 ± 10	...
B	yes	99 ± 4	Spillover point
C	yes	85 ± 3	Internal measurement difficult, used by manufacturer for assembly. Dimension is where center of angled inner tube intersects with the inner wall of the vertical column
D (OD)	no	64.5 ± 2	...
E	no	14/23 or 19/38	Tapered ground joint – female <sup>B</sup>
F	no	35/25	Spherical ground joint – male <sup>B</sup>
G	no	35 ± 10	This area to be covered by the insulating top of the heating mantle
H (ID)	yes	24.7 ± 1.2	Use of 28 mm OD tubing achieves this dimension
I	no	2 – 12	Window allows observation of boil-up rate and column cleanliness, but also allows detrimental heat loss
J	no	60 ± 20	...
K	no	12 ± 7	...
L (OD)	no	8	Minimum, cooling medium connections
M	yes	230 ± 13	This dimension determines condensed vapor run down time and affects temperature/recovery results
N (OD)	no	38 ± 2	...
O	yes	140 ± 20	This dimension affects vapor condensing efficiency which influences temperature/recovery results
P (ID)	yes	18.7 ± 1.1	Use of 22 mm OD tubing achieves this dimension
Q	yes	60 ± 2°	...
R	no	not applicable	Connection to vacuum system; any suitable means is allowed
S	no	not applicable	Extension above condensing section; must maintain minimum or greater internal diameter of condensing section
T (ID)	yes	18.7 ± 1.1	Use of 22 mm OD tubing achieves this dimension
U	yes	140 ± 5	This dimension affects vapor condensing efficiency which influences temperature/recovery results
V	no	not applicable	Extensions on the upper and lower portions of the condensing section vary by manufacturer and have no influence on the test
W	no	12 ± 7	...
X	yes	50 ± 8	...
Y	yes	30 ± 7	Distance to end of drip tip

<sup>A</sup> All dimensions are in millimetres.

<sup>B</sup> Ground glass joints from different sources may have one of a number of diameter to length ratios. For purposes of this test method, any are suitable, and in some instances, the diameter itself is not critical. However, it is critical that the male and female parts of each joint are from the same series to avoid recession or protuberance.

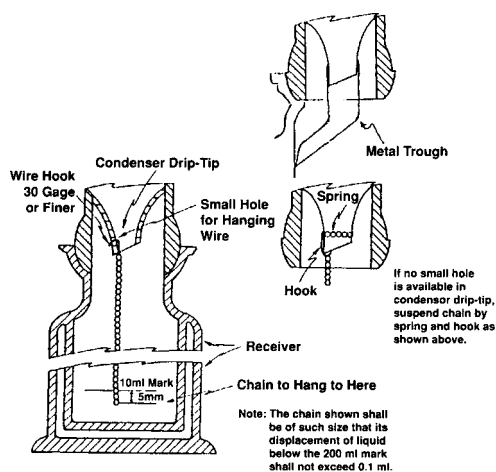

FIG. 5 Detail of Drip-Chain or Trough Attachment to Condenser

good cathetometer (an instrument based on a telescope mounted on a vernier scale to determine levels very accurately). An electronic gage such as the Baratron is satisfactory

when calibrated from a McLeod gage but must be rechecked periodically as described in Annex A3. A suitable pressure calibration setup is illustrated in Fig. A3.1. Vacuum gages based on hot wires, radiation, or conductivity detectors are not recommended.

NOTE 2—Suitable instruments for measuring the pressure of the system during the test are the tensimeter or an electronic pressure gage, provided the output is traceable to a primary gage, such as the non-tilting McLeod gage.

6.1.5.1 Connect the vacuum gage to the side tube of the temperature sensor/vacuum adapter of the distillation column (preferred location) or to the side tube of the sensor/vacuum adapter of the condenser when assembling the apparatus. Connections shall be as short in length as possible and have an inside diameter not less than 8 mm.

6.1.6 Pressure Regulating System, capable of maintaining the pressure of the system constant within 0.01 kPa at pressures of 1 kPa absolute and below and within 1 % of the absolute pressure at 1 kPa or higher. Suitable equipment for this purpose is described in Annex A4. Connect the pressure regulating

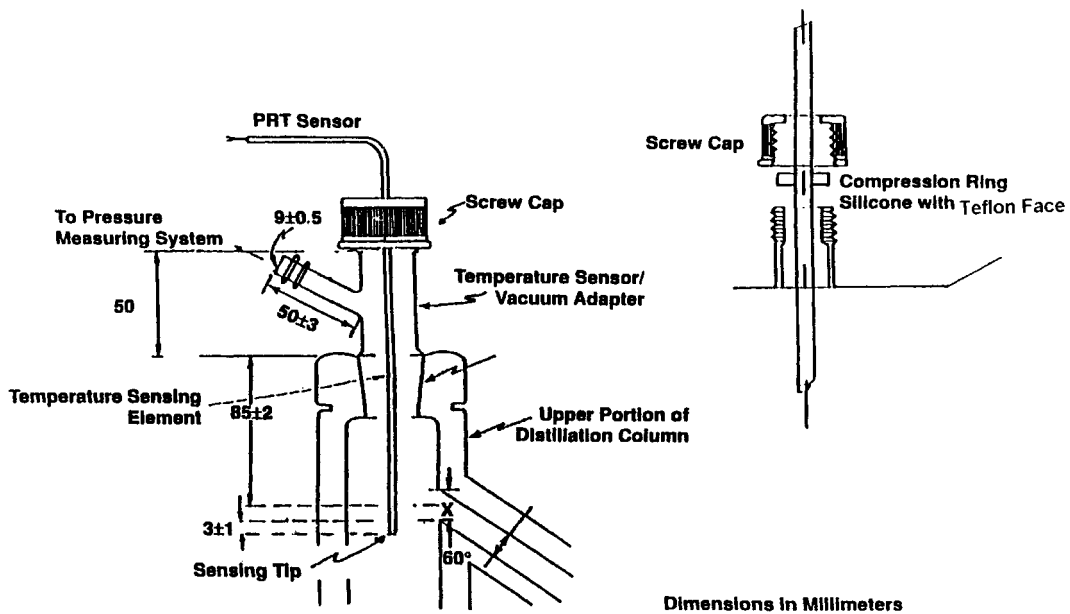

NOTE 1—Dimensions are in millimetres.  
 FIG. 6 Location of Temperature Sensor

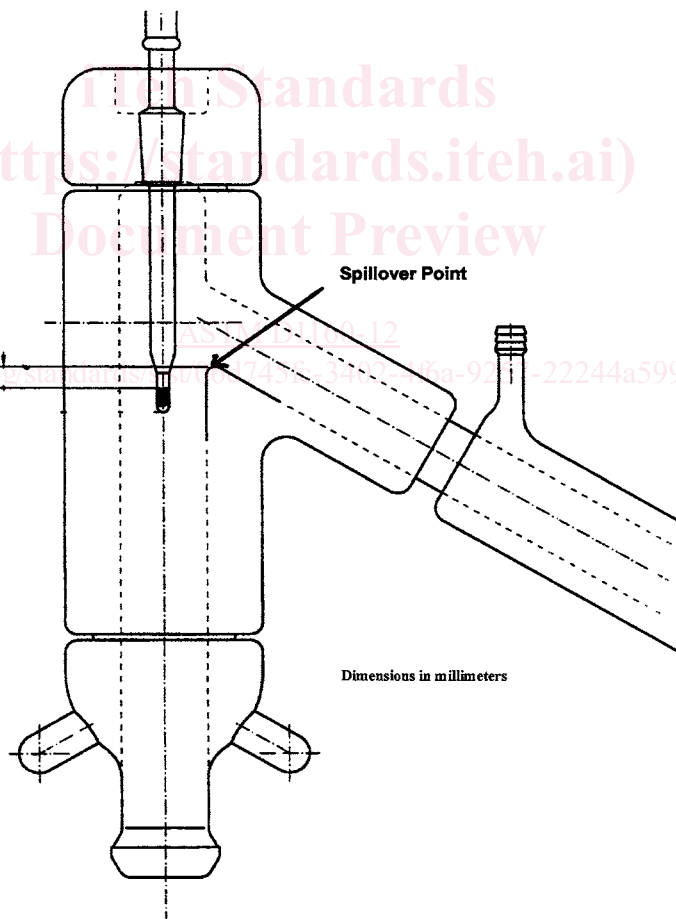

FIG. 7 Platinum Resistance Temperature Measuring Device

system to the tube at the top of the condenser when assembling the apparatus. Connections shall be as short in length as possible and have an inside diameter not less than 8 mm.

6.1.7 *Vacuum Source*, consisting of, for example, one or more vacuum pumps and several surge tanks, capable of maintaining the pressure constant within 1 % over the full