



Designation: E561 – 10^{ε2}

Standard Test Method for K-R Curve Determination¹

This standard is issued under the fixed designation E561; the number immediately following the designation indicates the year of original adoption or, in the case of revision, the year of last revision. A number in parentheses indicates the year of last reapproval. A superscript epsilon (ϵ) indicates an editorial change since the last revision or reapproval.

¹ NOTE—3.2.2 was editorially updated in December 2011.

² NOTE—3.2.2 was editorially updated in March 2013.

1. Scope*

1.1 This test method covers the determination of the resistance to fracture of metallic materials under Mode I loading at static rates using either of the following notched and precracked specimens: the middle-cracked tension M(T) specimen or the compact tension C(T) specimen. A K - R curve is a continuous record of toughness development (resistance to crack extension) in terms of K_R plotted against crack extension in the specimen as a crack is driven under an increasing stress intensity factor, K .

1.2 Materials that can be tested for K - R curve development are not limited by strength, thickness, or toughness, so long as specimens are of sufficient size to remain predominantly elastic to the effective crack extension value of interest.

1.3 Specimens of standard proportions are required, but size is variable, to be adjusted for yield strength and toughness of the materials.

1.4 Only two of the many possible specimen types that could be used to develop K - R curves are covered in this method.

1.5 The test is applicable to conditions where a material exhibits slow, stable crack extension under increasing crack driving force, which may exist in relatively tough materials under plane stress crack tip conditions.

1.6 The values stated in SI units are to be regarded as the standard. The values given in parentheses are for information only.

1.7 *This standard does not purport to address all of the safety concerns, if any, associated with its use. It is the responsibility of the user of this standard to establish appropriate safety and health practices and determine the applicability of regulatory limitations prior to use.*

¹ This test method is under the jurisdiction of ASTM Committee E08 on Fatigue and Fracture and is the direct responsibility of Subcommittee E08.07 on Fracture Mechanics.

Current edition approved Nov. 1, 2010. Published November 2010. Originally approved in 1974. Last previous edition approved in 2008 as E561 – 08 ^{ε1}. DOI: 10.1520/E0561-10E02.

2. Referenced Documents

2.1 *ASTM Standards*:²

E4 Practices for Force Verification of Testing Machines
E399 Test Method for Linear-Elastic Plane-Strain Fracture Toughness K_{Ic} of Metallic Materials
E1823 Terminology Relating to Fatigue and Fracture Testing

2.2 *Other Document*:

AISC Steel Construction Manual³

3. Terminology

3.1 *Definitions*—Terminology E1823 is applicable to this method.

3.2 *Definitions of Terms Specific to This Standard*:

3.2.1 *apparent plane-stress fracture toughness, K_{app}* —The value of K calculated using the original crack size and the maximum force achieved during the test. K_{app} is an engineering estimate of toughness that can be used to calculate residual strength. K_{app} depends on the material, specimen size, and specimen thickness and as such is not a material property.

3.2.2 *effective modulus, E_{eff} [FL^{-2}]*—an elastic modulus that allows a theoretical (modulus normalized) compliance to match an experimentally measured compliance for an actual initial crack size a_o .

3.2.3 *plane-stress fracture toughness, K_c* —The value of K_R at instability in a force-controlled test corresponding to the maximum force point in the test. K_c depends on the material, specimen size, and specimen thickness and as such is not a material property.

3.2.3.1 *Discussion*—See the discussion of plane-strain fracture toughness in Terminology E1823.

4. Summary of Test Method

4.1 During slow-stable fracturing, the developing crack extension resistance K_R is equal to the applied stress intensity

² For referenced ASTM standards, visit the ASTM website, www.astm.org, or contact ASTM Customer Service at service@astm.org. For *Annual Book of ASTM Standards* volume information, refer to the standard's Document Summary page on the ASTM website.

³ Available from American Institute of Steel Construction (AISC), One E. Wacker Dr., Suite 3100, Chicago, IL 60601-2001.

*A Summary of Changes section appears at the end of this standard

factor K . The crack is driven forward by continuously or incrementally increasing force or displacement. Measurements are made periodically for determination of the effective crack size and for calculation of K values, which are individual data points that define the K - R curve for the material under those test conditions.

4.2 The crack starter is a low-stress-level fatigue crack.

4.3 The method covers two techniques for determination of effective crack size: (1) direct measurement of the physical crack size which is then adjusted for the developing plastic zone size, and (2) compliance measurement techniques that yield the effective crack size directly. Methods of measuring crack extension and of making plastic-zone corrections to the physical crack size are prescribed. Expressions for the calculation of crack-extension force K_R are given. Criteria for determining if the specimen conditions are predominantly elastic are provided.

5. Significance and Use

5.1 The K - R curve characterizes the resistance to fracture of materials during slow, stable crack extension and results from the growth of the plastic zone ahead of the crack as it extends from a fatigue precrack or sharp notch. It provides a record of the toughness development as a crack is driven stably under increasing applied stress intensity factor K . For a given material, K - R curves are dependent upon specimen thickness, temperature, and strain rate. The amount of valid K - R data generated in the test depends on the specimen type, size, method of loading, and, to a lesser extent, testing machine characteristics.

5.2 For an untested geometry, the K - R curve can be matched with the crack driving (applied K) curves to estimate the degree of stable crack extension and the conditions necessary to cause unstable crack propagation (1).⁴ In making this estimate, K - R curves are regarded as being independent of original crack size a_o and the specimen configuration in which they are developed. For a given material, material thickness, and test temperature, K - R curves appear to be a function of only the effective crack extension Δa_e (2).

5.2.1 To predict crack behavior and instability in a component, a family of crack driving curves is generated by calculating K as a function of crack size for the component using a series of force, displacement, or combined loading conditions. The K - R curve may be superimposed on the family of crack driving curves as shown in Fig. 1, with the origin of the K - R curve coinciding with the assumed original crack size a_o . The intersection of the crack driving curves with the K - R curve shows the expected effective stable crack extension for each loading condition. The crack driving curve that develops tangency with the K - R curve defines the critical loading condition that will cause the onset of unstable fracture under the loading conditions used to develop the crack driving curves.

5.2.2 Conversely, the K - R curve can be shifted left or right in Fig. 1 to bring it into tangency with a crack driving curve to

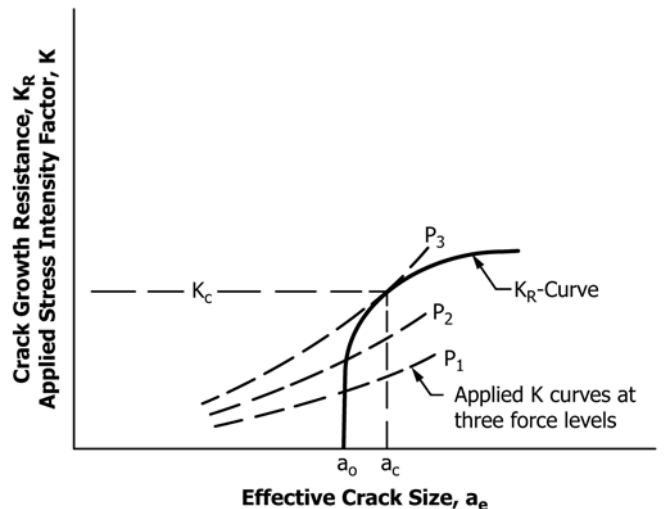

FIG. 1 Schematic Representation of K - R curve and Applied K Curves to Predict Instability; K_c , P_3 , a_c , Corresponding to an Original Crack Size, a_o

determine the original crack size that would cause crack instability under that loading condition.

5.3 If the K -gradient (slope of the crack driving curve) of the specimen chosen to develop the K - R curve has negative characteristics (see Note 1), as in a displacement-controlled test condition, it may be possible to drive the crack until a maximum or plateau toughness level is reached (3, 4, 5). When a specimen with positive K -gradient characteristics (see Note 2) is used, the extent of the K - R curve which can be developed is terminated when the crack becomes unstable.

NOTE 1—Fixed displacement in crack-line-loaded specimens results in a decrease of K with crack extension.

NOTE 2—With force control, K usually increases with crack extension, and instability will occur at maximum force.

6. Apparatus

6.1 *Testing Machine*—Machines used for K - R curve testing shall conform to the requirements of Practices E4. The forces used in determining K_R values shall be within the verified force application range of the testing machine as defined in Practices E4.

6.2 *Grips and Fixtures for Middle-Cracked Tension (M(T)) Specimens*—In middle-cracked tension specimens, the grip fixtures are designed to develop uniform stress distribution in the central region of the specimen. Single pin grips can be used on specimens less than 305 mm (12 in.) wide if the specimen is long enough to ensure uniform stress distribution in the crack plane (see 8.5.3). For specimens wider than 305 mm (12 in.), multiple-bolt grips such as those shown in Fig. 2 or wedge grips that apply a uniform displacement along the entire width of the specimen end shall be used if the stress intensity factor and compliance equations in Section 11 are to be used. Other gripping arrangements can be used if the appropriate stress intensity factor and compliance relationships are verified and used. Grips should be carefully aligned to minimize the introduction of bending strain into the specimen. Pin or gimbal connections can be located between the grips and testing

⁴ The boldface numbers in parentheses refer to the list of references at the end of this standard.

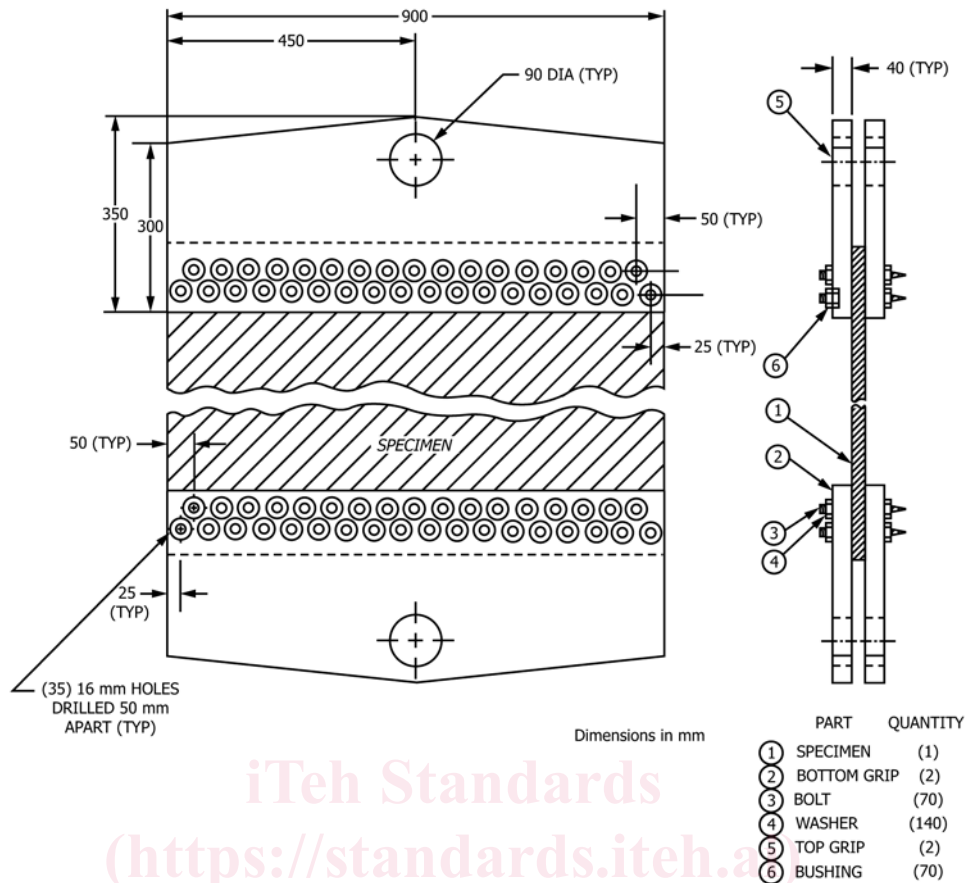

FIG. 2 Middle-Cracked Tension (M(T)) Panel Test Setup

machine to aid the symmetry of loading. If extra-heavy-gauge, high-toughness materials are to be tested, the suitability of the grip arrangement may be checked using the *AISC Steel Construction Manual*.

6.3 Grips and Fixtures for Compact Tension (C(T)) Specimens—The grips and fixtures described in Test Method E399 are recommended for *K-R* curve testing where C(T)-type specimens are loaded in tension.

6.4 Buckling Constraints—Buckling may develop in unsupported specimens depending upon the specimen thickness, material toughness, crack size, and specimen size (6). Buckling seriously affects the validity of a *K* analysis and is particularly troublesome when using compliance techniques to determine crack size (7). It is therefore required that buckling constraints be affixed to the M(T) and C(T) specimens in critical regions when conditions for buckling are anticipated. A procedure for the detection of buckling is described in 9.8.3.

6.4.1 For an M(T) specimen in tension, the regions above and below the notch are in transverse compression which can cause the specimen to buckle out of plane. The propensity for buckling increases as *W/B* and *2a/W* ratios increase and as the force increases. Unless it can be shown by measurement or analysis that buckling will not occur during a test, buckling constraints shall be attached to the central portion of the specimen. The guides shall be so designed to prevent sheet kinking about the crack plane and sheet wrinkling along the

specimen width. Buckling constraints should provide a high stiffness constraint against out-of-plane sheet displacements while minimizing friction. Buckling constraints with additional pressure adjustment capability near the center of the specimen are recommended (6). Friction between the specimen and the buckling constraints shall not interfere with the in-plane stress distribution in the specimen. Friction can be minimized by using a low-friction coating (such as thin TFE-fluorocarbon sheet) on the contact surfaces of the constraints and by using just enough clamping force to prevent buckling while allowing free movement of the guides along the length of the specimen. A suspension system to prevent the buckling constraint from sliding down the specimen is recommended. Several buckling constraint configurations for M(T) specimens are shown in (7) and (8).

6.4.2 For C(T) specimens, the portion of the specimen arms and back edge which are in compression may need to be restrained from buckling in thinner specimens of high toughness alloys. It is convenient to use a base plate and cover plate with ports cut at appropriate locations for attaching clip gages and for crack size observations. Friction between buckling restraints and specimen faces is detrimental and should be minimized as much as possible.

6.4.3 Lubrication shall be provided between the face plates and specimen. Care shall be taken to keep lubricants out of the crack. Sheet TFE-fluorocarbon or heavy oils or both can be

used. The initial clamping forces between opposing plates should be high enough to prevent buckling but not high enough to change the stress distribution in the region of the crack tip at any time during the test.

6.5 Displacement Gages—Displacement gages are used to accurately measure the crack-mouth opening displacement (CMOD) across the crack at a specified location and span. For small C(T) specimens, the gage recommended in Test Method E399 may have a sufficient linear working range to be used. However, testing specimens with W greater than 127 mm (5 in.) may require gages with a larger working range, such as the gage shown in Fig. 3.

6.5.1 A recommended gage for use in M(T) specimens is shown in Fig. 4 (9). This gage is inserted into a machined hole having a circular knife edge. The diameter d_i is the gage span $2Y$ used in the calibration. Detail drawings of the gage are given in Fig. 5. Radius of the attachment tip should be less than the radius of the circular knife edge in the specimen.

6.5.2 The gage recommended in 6.5.1 is preferred because of its excellent linearity characteristics and ease of attachment. However, other types of gages used over different span lengths are equally acceptable provided the precision and accuracy requirements are retained. For example, the conventional clip gage of Test Method E399 may be used with screw attached knife edges spanning the crack at a chosen span $2Y$. In M(T) tests, the proper compliance calibration curve must be used because compliance is a function of Y/W . When using the compliance calibration curve given in Eq 5, the proper $2Y$ value to use with screw-on knife edges is the average distance between attachment points across the notch. This is the actual deformation measurement point, not the gage length of the clip gage itself.

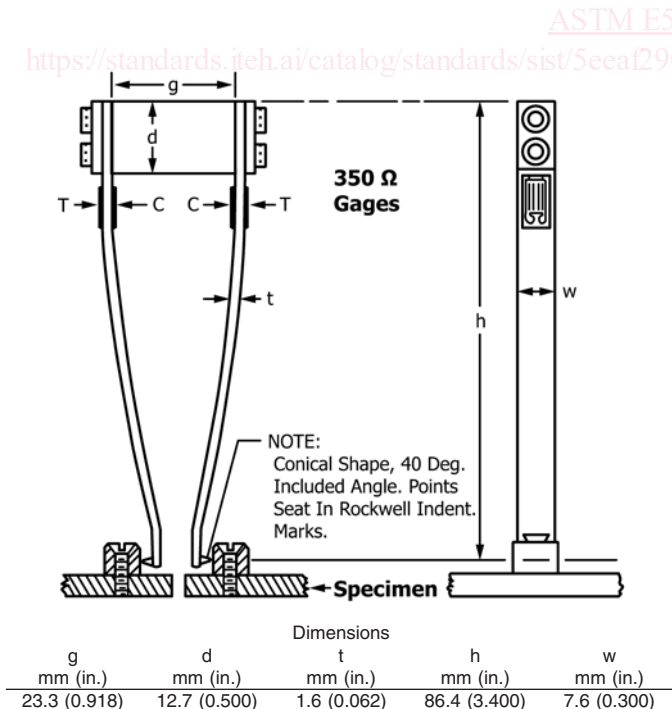

FIG. 3 Enlarged Clip Gage for Compliance Measurements on Large Specimens

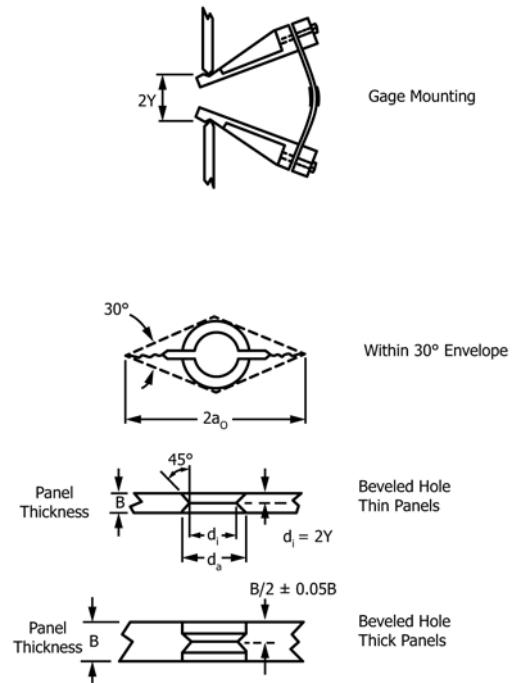

FIG. 4 Recommended Gage for Use in Drilled Hole M(T) Panels

6.5.3 The use of point contacts eliminates error in the readings from the hinge-type rotation of C(T) specimens. The precision of all types of gages shall be verified in accordance with the procedure in Test Method E399. In addition, absolute accuracy within 2 % of reading over the working range of the gage is required for use with compliance measurements. Data for compliance measurements must be taken within the verified range of the gage. The gages shall be verified periodically.

6.6 Optical Equipment—If the material being tested is sufficiently thin so that the crack-tip contour does not vary significantly from surface to mid-thickness, crack extension can be followed by surface observations using optical equipment. If force is sustained at given increments so that the crack stabilizes, physical crack size can be determined within 0.2 mm (0.01 in.) using a 30 to 50-power traveling-stage microscope. A video or CCD camera recording system may also be useful for determining in-plane strain distribution and out-of-plane displacements (10).

6.7 Other Equipment—Other methods of measuring crack length are available, such as eddy-current probes, which are most useful with nonferrous material, or electrical-resistance measurements, where the extension of the crack is determined from electrical potential differences.

6.8 Data Recording Equipment—When running a continuous monotonic test, a system capable of recording force and displacement signals with high fidelity at data rates to capture at least 200 force-CMOD data pairs during the test should be used. Appropriate data filtering can be used provided it does not introduce errors into the data.

7. Specimen Compliance Measurement Requirements

7.1 In the $K-R$ test, the effective crack size is determined either by direct measurement of the physical crack size and

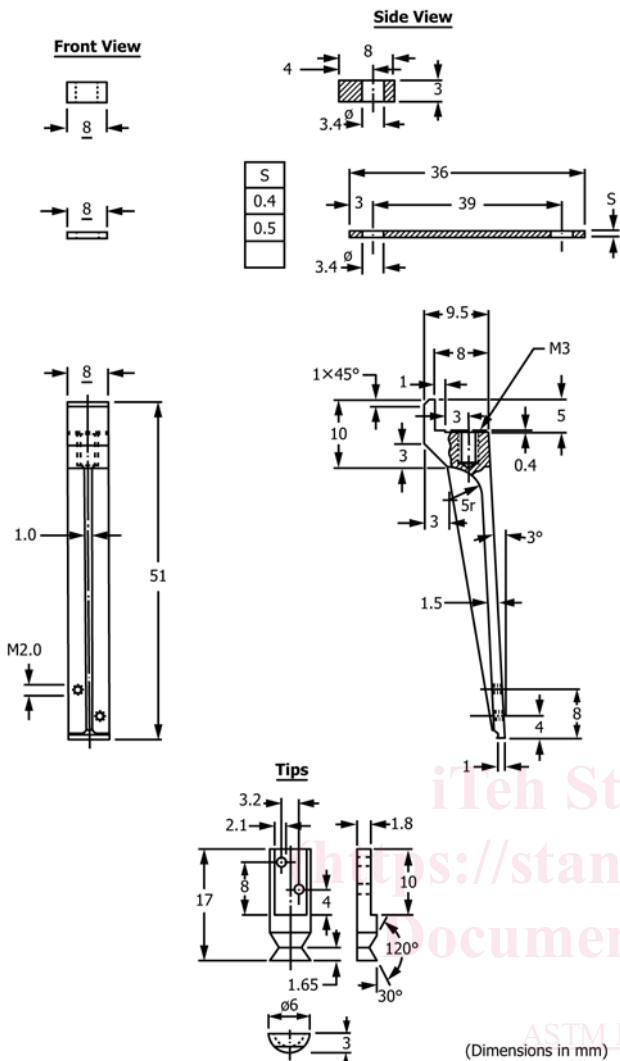

FIG. 5 Detail Drawings of Clip Gage for Use with the M(T) Specimen

adjusting for the crack tip plastic zone, or by specimen compliance techniques which can determine effective crack size directly. This section provides background and requirements for the use of compliance techniques.

7.2 Specimen compliance is the ratio of the change in specimen displacement to the change in force carried by the specimen ($\Delta v/\Delta P$) during the test. The loading compliance technique and the calibration information are used to determine effective crack size a_e directly. The crack size is automatically corrected for the plastic-zone and these values of a_e can be used directly in the appropriate stress intensity factor solutions to determine K_R . Unloading compliance can also be used to determine physical crack size a_p . In this technique, the specimen compliance is measured during periodic load reversals during the test. Specimen unloading compliance values are substituted into the appropriate calibration curve or compliance expression to determine physical crack size a_p . In this case, effective crack size can be computed by adding the plastic zone size at each measurement point.

7.3 The single compliance technique uses specimen displacement measured at a single location, for example the front face mouth opening for C(T) specimens or spanning the notch at the specimen midplane for M(T) specimens.

7.4 Specimen compliance is measured by simultaneously recording the force and CMOD during the test. The effective crack size can be determined directly by calculating $\Delta v/\Delta P$ in the single compliance method. Crack size is determined from compliance measurements using the compliance equations or tables for the specimen tested as described in Section 11.

7.5 The compliance technique uses elastic-spring characteristics of the specimen calibrated over a variety of crack sizes (11). Compliance calibration curves have been developed for various specimen geometries analytically using finite element methods or experimentally using specimens containing various crack sizes. The change in CMOD (Δv) of specific measurement points on the specimen is determined as a function of the change in force (ΔP). The slopes are normalized for material thickness and elastic modulus and plotted against the ratio of crack size to specimen width, providing a calibration curve of $EB(\Delta v/\Delta P)$ as a function of a/W for the C(T) specimens or $2a/W$ for the M(T) specimen. Analytical expressions for the normalized compliance of the two specimen types covered in this method are given in Section 11 for specified displacement measurement points.

8. Specimen Configuration, Dimensions, and Preparation

8.1 Specimen Type—This method covers two specimen types: M(T) and C(T). The choice of specimen type depends on the amount of material available, the type of test to be run, and the type of equipment available. Ideally, the K - R curve should not depend on the specimen type, although the amount of valid K - R curve generated will depend on the specimen type and size. If the material is highly anisotropic, it may be preferable to use the M(T) specimen because the high stress gradient of the C(T) specimen may be more prone to exhibit crack deviation. The following sections provide information about each specimen type.

NOTE 3—Difficulties in the interpretation of test records will be encountered if the specimens are not flat prior to testing or if the specimen contains substantial residual stress.

8.2 Number of Tests—Replicate K - R curves can be expected to vary as with other mechanical properties. Test-to-test variability in K - R curves also depends on the material being tested. It is recommended that at least duplicate tests on multiple lots of material be performed when developing design data. For quality assurance testing, a single test can be performed.

8.3 Specimen Size—In order for a given calculated K_R value to be valid, the remaining uncracked ligament in the plane of the crack must be predominantly elastic at the value of applied force and physical crack size corresponding to that value of K_R . Methods for estimating specimen size to ensure predominantly elastic conditions over a wide range of Δa_e values are provided for each specimen type below. Methods for determining invalid data points are provided in subsequent sections of the method.

8.4 Starting Notch and Pre-crack—The machined starter notch for either of the recommended specimens may be made

by electrical-discharge machining, end milling, or saw cutting. It is advisable to have a root radius at the ends of the notch of 0.08 mm (0.003 in.) or less to facilitate fatigue precracking. Fatigue precracking is highly recommended and may be omitted only if it has been demonstrated for the material and thickness of interest that the machined notch root radius effectively simulates the sharpness of a fatigue precrack. The starter notch should be extended by fatigue precrack not less than 1.3 mm (0.05 in.) in length. The procedure for precracking is given in Testing Procedures, Section 9.

8.5 Middle-Cracked Tension (M(T)) Specimen:

8.5.1 The middle-cracked tension (M(T)) specimen is a rectangular specimen containing a centrally-located starter notch that is pulled in tension in the length direction of the specimen.

8.5.2 The ends of the specimen may contain a single pin-loading hole or may be configured for gripping with multiple-bolt grips or wedge grips along the two ends of the specimen as shown in Fig. 2.

8.5.3 To ensure uniform stress entering the crack plane when single-pin grips are used, the length between the loading pins shall be at least three specimen widths, 3W. For specimens wider than 305 mm (12 in.), multiple-bolt grips such as those shown in Fig. 2 or wedge grips that apply a uniform displacement along the entire width of the specimen end shall be used. In this case, the length requirement between the innermost gripping points is relaxed to 1.5W.

8.5.4 A starter notch is machined perpendicular to the tension direction, centered at mid-width and located midway along the length of the specimen. The machined notch length shall be between 0.25 and 0.40W and shall be centered with respect to the specimen width within 0.002W. The machined notch must lie within the envelope shown in Fig. 6. A fatigue precrack shall be initiated from each end of the starter notch using the procedure in 9.2. The fatigue precrack shall extend from the starter notch by at least 1.3 mm (0.05 in.) and must extend beyond the envelope shown in Fig. 6. The original crack size, 2a_o (machined notch plus fatigue precrack) shall be within the range of 0.25 to 0.40W.

8.5.5 In the M(T) specimen, crack size a in the equations of Section 11 is the dimension from the specimen centerline to the crack tip. This assumes that the crack is perfectly symmetrical with respect to the specimen centerline. In practice, this is the half of the average tip-to-tip crack length measurement.

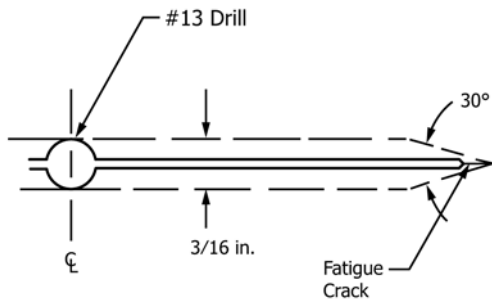

FIG. 6 Enlarged View of the Right Half of the Permitted Notch Envelope in M(T) Panels

8.5.6 For specimen compliance determination, CMOD measurements are made between points spanning the machined notch at the mid-width of the specimen. This can be done by attaching knife edges to the specimen with screws or cement to accept a commercial clip gage or the one shown in Fig. 3. The specimen can also be machined with integral knife edges using tapered holes as shown in Fig. 4. The CMOD gage shown in Fig. 5 fits into these knife edges.

8.5.7 To ensure predominantly elastic conditions in the M(T) specimen, the net section stress based on the physical crack size must be less than the yield strength of the material at the test temperature. The M(T) specimen width W and original crack size a_o should be selected to provide valid K_R data up to effective crack extension values of interest. In general, a wider specimen will provide valid data up to a larger value of effective crack extension than a narrow specimen.

8.5.8 The required width to maintain predominantly elastic conditions for a given value of K_R may be estimated from the maximum expected plastic-zone size, r_y (see Section 10), which is directly proportional to the square of the material toughness-to-yield strength ratio. As a guide, a specimen 27r_y wide and with an original crack size 2a_o of 0.33W is expected to fail at a net section stress equal to the yield strength (12). It therefore is desirable to have an estimate of the maximum value of K_R expected in the test before designing the specimen. As an aid, the following table lists minimum recommended M(T) sizes for assumed ratios of K_{Rmax} to yield strength.

Table of Minimum M(T) Specimen Geometry for Given Conditions							
K _{Rmax} /σ _{YS}		Width		2 a _o		Length ^A	
√m	√in.	m	in.	m	in.	m	in.
0.08	0.5	0.076	3.0	0.025	1.0	0.229	9
0.16	1.0	0.152	6.0	0.051	2.0	0.457	18
0.24	1.5	0.305	12.0	0.102	4.0	0.914	36
0.32	2.0	0.508	20.0	0.170	6.7	0.762	30
0.48	3.0	1.219	48.0	0.406	16.0	1.829	72

^A Distance between pin centers of single pin loaded M(T) specimens is nominally 3W. Specimens wider than 305 mm (12 in.) will require multiple pin grips or full-width gripping and the length requirement for the distance between nearest gripping points is relaxed to 1.5W.

8.6 Compact Tension (C(T)) Specimen:

8.6.1 The recommended C(T) specimen is shown in Fig. 7. The specimen is loaded in tension with clevis grips using pins inserted through the loading holes. The loading hole size is proportional to the specimen width.

8.6.2 Fig. 8 shows the allowable notch types and envelope sizes for this specimen. The notch is machined perpendicular to the loading axis and is centered with respect to the top and bottom edges of the specimen. A fatigue precrack shall be initiated from the notch tip using the procedure in 9.2. The fatigue precrack shall extend from the starter notch by at least 1.3 mm (0.05 in.) and must extend beyond the envelope shown in Fig. 8.

8.6.3 The original crack size a_o (that is, machined notch plus fatigue precrack) in the C(T) specimens shall be between 0.35 and 0.55W.

8.6.4 For specimen compliance determination, CMOD measurements are made across the notch at either location V₀ or V₁ in Fig. 7 (0.25W ± 0.0006W or 0.1576W ± 0.0006W in advance of the loading hole centerline). Span of the gage is not critical so long as it is less than W/4. Alternative location of the