

INTERNATIONAL STANDARD

ISO 3187

First edition
1989-07-01

Refractory products — Determination of creep in compression

Produits réfractaires — Détermination du fluage à la compression

iTeh STANDARD PREVIEW
(standards.iteh.ai)

[ISO 3187:1989](https://standards.iteh.ai/catalog/standards/sist/57e4dfdf-de35-445b-b93c-c6fed36e4e8a/iso-3187-1989)

<https://standards.iteh.ai/catalog/standards/sist/57e4dfdf-de35-445b-b93c-c6fed36e4e8a/iso-3187-1989>



Reference number
ISO 3187 : 1989 (E)

Foreword

ISO (the International Organization for Standardization) is a worldwide federation of national standards bodies (ISO member bodies). The work of preparing International Standards is normally carried out through ISO technical committees. Each member body interested in a subject for which a technical committee has been established has the right to be represented on that committee. International organizations, governmental and non-governmental, in liaison with ISO, also take part in the work. ISO collaborates closely with the International Electrotechnical Commission (IEC) on all matters of electrotechnical standardization.

Draft International Standards adopted by the technical committees are circulated to the member bodies for approval before their acceptance as International Standards by the ISO Council. They are approved in accordance with ISO procedures requiring at least 75 % approval by the member bodies voting.

International Standard ISO 3187 was prepared by Technical Committee ISO/TC 33, *Refractories*.

<https://standards.iteh.ai/catalog/standards/sist/57e4dfdf-de35-445b-b93c-6fd3c4e8a/iso-3187-1989>

Annex A of this International Standard is for information only.

© ISO 1989

All rights reserved. No part of this publication may be reproduced or utilized in any form or by any means, electronic or mechanical, including photocopying and microfilm, without permission in writing from the publisher.

International Organization for Standardization
Case postale 56 • CH-1211 Genève 20 • Switzerland

Printed in Switzerland

Refractory products — Determination of creep in compression

1 Scope

This International Standard specifies a method for determining creep in compression, which is the deformation of a refractory material or product subjected to a constant load under isothermal conditions.

The test rig used in this method of test is the same as that used for the determination of refractoriness-under-load (see ISO 1893).

NOTE — The apparatus described is generally suitable for determination of creep in compression up to 1 600 °C.

2 Normative references

The following standards contain provisions which, through reference in this text, constitute provisions of this International Standard. At the time of publication, the editions indicated were valid. All standards are subject to revision, and parties to agreements based on this International Standard are encouraged to investigate the possibility of applying the most recent editions of the standards listed below. Members of IEC and ISO maintain registers of currently valid International Standards.

ISO/R 836 : 1968, *Vocabulary for the refractories industry*.

ISO 1893 : 1989, *Refractory products — Determination of refractoriness-under-load (differential — with rising temperature)*.

IEC 584-1 : 1977, *Thermocouples — Part 1: Reference tables*.

IEC 584-2 : 1982, *Thermocouples — Part 2: Tolerances*.

3 Definition

For the purposes of this International Standard, the following definition applies.

creep: Isothermal deformation of a stressed product as a function of time.¹⁾

4 Principle

A test piece of given dimensions is heated under specified conditions to a given temperature and at one of two specified stages (see 7.2) in the test a constant compressive load is applied to it. The deformation of the test piece at constant temperature is recorded and the percentage change is evaluated as a function of time.

There are two forms of the test, one where the load is applied at room temperature and the other where it is applied at the test temperature.

NOTE — The values between the end of the fifth hour creep and the end of the test are usually in close agreement.

5 Apparatus

5.1 Loading device

5.1.1 General

The loading device shall be capable of applying a load centred on the common axis of the loading column, the test piece and the supporting column, and directed vertically along this axis at all stages of the test. The loading device consists of the items given in 5.1.2 to 5.1.5.

A constant compressive load is applied in a downward direction from above on the piece resting directly or indirectly on a fixed base. It follows that the deformation of the test piece is required to be measured by some device that passes either through the applied load or through an intermediate base. For simplicity, the text and the figures 1 and 2 in this International Standard show the measuring device passing through the base but, by interchanging the bored column and refractory plate with the unbored column and plate, it may be arranged that the measuring device passes through the load, as in figure 3.

NOTE — Although both arrangements are within the scope of the standard, it is preferable that the measuring device should be positioned below the assembly, as shown in the figures. The reasons for this are outlined in annex A.

1) This definition is taken from ISO/R 836.

5.1.2 Fixed column, at least 45 mm in overall diameter and with an axial bore (see 5.1.5).

5.1.3 Moving column, at least 45 mm in overall diameter.

NOTE — Arrangements can be made for the upper moving column to be fixed to the furnace, and the combination of furnace and column then forms the moveable loading device.

5.1.4 Two discs, 5 mm to 10 mm thick and at least 50 mm in diameter of an appropriate refractory material compatible with the material under test (e.g. high-fired mullite or alumina for alumino-silicate products, and magnesia or spinel for basic products) which are placed between the test piece and the fixed and moving columns. The disc placed between the test piece and the fixed column shall have a central bore (see 5.1.5). The ends of the fixed and moving columns shall be plane and perpendicular to their axes; the faces of each disc shall be plane and parallel.

NOTE — Platinum or platinum/rhodium sheet (0,2 mm) may be placed between the sample and the discs to prevent chemical reaction, particularly in the case of silica.

5.1.5 The arrangement of the two columns, the two discs, the platinum sheet if used, and the test piece is shown in figure 2, which also shows typical diameters of the bores in the fixed column and in the disc between them.

5.1.6 The columns and discs shall be capable of withstanding the applied load up to the final test temperature without significant deformation. There should be no reaction between the discs and the loading system.

5.2 Furnace (preferably with a vertical axis), capable of raising the temperature of the test piece to the final test temperature at the specified rate (see 7.4) in an atmosphere of air. The temperature of the region of the furnace occupied by the test piece, when above 500 °C at a stable temperature, shall be uniform around the test piece (12,5 mm above and below) to within ± 20 K; this shall be verified by carrying out tests using thermocouples located at different points on the curved surface of the test piece. During the period of constant temperature, the fluctuations of temperature indicated by the control thermocouple shall not exceed 5 K.

NOTE — The furnace design should be such that the whole of the column assembly can be easily reached, either by movement of the supporting column or, if access into the furnace is restricted, by movement of the furnace itself. The assembly should be such that the test piece and loading column stand vertically and co-axial with the support column when unrestrained.

5.3 Measuring device, consisting of the following items :

5.3.1 Outer alumina tube, placed inside the fixed column to abut on the lower side of the lower disc, and free to move within the fixed column (see 5.3.3).

5.3.2 Inner alumina tube, placed inside the outer tube and passing through the bores in the lower disc and in the test piece to abut on the lower face of the upper disc, and free to move within the outer tube, the lower disc and the test piece (see 5.3.3).

5.3.3 The arrangement of the two tubes, the two discs and the test piece as shown in figure 2, which also indicates typical external and internal diameters of the outer and inner tubes.

5.3.4 Appropriate measuring instrument (for example a dial-gauge or a length transducer connected to an automatic recording system), fixed to the end of the outer tube (see 5.3.1) and actuated by the inner tube (see 5.3.2). The sensitivity of the measuring device shall be at least 0,005 mm.

5.3.5 The alumina tubes shall be capable of withstanding the load imposed on them by the measuring instrument at all temperatures up to the final test temperature without significant distortion.

5.4 Temperature-measurement devices

5.4.1 Central thermocouple, passing through the inner alumina tube (see 5.3.2) of the dilatometer, with its junction at the mid-point of the test piece, for measuring the temperature of the test piece at its geometric centre.

5.4.2 Control thermocouple, which shall be placed in a sheath and situated outside the test piece (see figure 1), for regulating the rate of rise of temperature.

NOTE — For certain furnace constructions, it may be advisable to place the thermocouple nearer to the heating elements.

5.4.3 The thermocouples shall be made from platinum and/or platinum-rhodium wire, and shall be compatible with the final test temperature. They shall be in accordance with IEC 584-1 or 584-2.

5.4.4 The accuracy of the thermocouples shall be checked on a regular basis.

5.5 Calipers, to measure to 0,1 mm.

6 Test piece

6.1 The test piece shall be a cylinder 50 mm \pm 0,5 mm in diameter and 50 mm \pm 0,5 mm in height, with a hole from 12 mm to 13 mm in diameter, extending throughout the height of the test piece, bored co-axially with the outer cylindrical surface.

NOTE — The axis of the test piece should preferably be in the direction in which the product was pressed.

6.2 The top and bottom faces of the test piece shall be made plane and parallel by sawing (and grinding if necessary), and shall be perpendicular to the axis of the cylinder. The surface of the cylinder shall be free from visible defects. Measurements of the height at any two points, using Vernier calipers, shall not differ by more than 0,2 mm. When one face of the test piece is placed on a plane surface and a set square also in contact with the surface is brought into contact with any part of the periphery of the test piece, the gap between the side of the test piece and the square shall not exceed 0,5 mm.

6.3 To ensure that the top and bottom ends of the test piece are flat over their entire surface, each end shall in turn be pressed onto a levelling plate which is lined with carbon paper and hard filter paper (0,15 mm in thickness). As an alternative to carbon paper, the ends of the test piece may be inked using a stamp pad. Test pieces that do not show two complete, clearly visible coloured impressions shall be re-ground.

NOTE — It is also permissible to control the flatness of the surface with a straightedge.

7 Procedure

7.1 Measure the height of the test piece to 0,1 mm, and measure the inner and outer diameters of the test piece. Set up the test piece between the supporting and loading columns with the spacing discs, and adjust the measuring device to the correct setting. Position the assembly within the furnace.

7.2 Apply a constant compressive load to the loading column at one or other of the following stages in the test :

- a) at the moment when the furnace is switched on, i.e. from ambient temperature;
- b) after the test piece has been maintained at the test temperature for a given time (minimum 1 h, maximum 4 h).

Which alternative is used shall be stated in the test report.

NOTE — Alternative b) is applicable if the behaviour of the material is only to be studied at the test temperature and allows the test piece to be exposed to a pre-test soak at the test temperature. The duration of this pre-treatment is stated in the test report.

7.3 The total load applied to the test piece, including the mass of the moving column and the associated disc, shall be such as to generate in the test piece a stress with one of the following values, with tolerance limits of $\pm 2\%$:

- a) for dense shaped products: 0,2 N/mm²;
- b) for shaped insulating products: 0,05 N/mm².

The total load used shall be rounded to the nearest 1 N.

NOTE — Tests for unshaped products are presently outside the scope of this International Standard because there is no standard method for preparing test pieces. However, if such tests are carried out using the method described, the recommended loads are

- a) 0,1 N/mm² for dense unshaped products;
- b) 0,05 N/mm² for unshaped insulating products.

7.4 Raise the temperature of the furnace at such a rate that the regulating thermocouple (see 5.4.2) indicates a rate of rise of temperature of between 4,5 K/min and 5,5 K/min.

NOTE — Up to a temperature of 500 °C, a heating rate of up to 10 K/min may be used.

7.5 In a test in which the load is applied when the furnace is switched on, record the changes in the height of the test piece and its temperature, at intervals not greater than 5 min during

the period of heating and for the first hour after attaining constant temperature as indicated by the control thermocouple. Thereafter record the changes at 30 min intervals to completion of the test.

7.6 In a test in which the load is applied after the test piece has been maintained for a period at constant temperature, record the change in height of the test piece and its temperature, starting when the load is applied, at 5 min intervals for the first hour and thereafter at 30 min intervals to completion of the test.

7.7 The standard time for testing shall be 25 h.

NOTES

- 1 Extensions may be agreed as required, up to a maximum of 100 h in multiples of 25 h.
- 2 If the subsidence of the test piece exceeds some specified percentage of its initial height, the test should be terminated.

8 Calculation of results

8.1 Load applied at ambient temperature

8.1.1 In a test in which the load is applied when the furnace is switched on, use the results obtained in 7.5 to plot the curve C_1 (see figure 4), representing the percentage change in the height of the test piece as a function of temperature, uncorrected for the changes in length of the alumina tubes (5.3.1 and 5.3.2).

8.1.2 Ascertain the changes in length, as a function of temperature, of a length of the inner alumina tube (5.3.2) equal to the nominal height of the test piece. Express the value of these changes as percentages of the nominal height of the test piece, H , and with these percentages plot the correction curve C_2 shown in figure 4.

8.1.3 Draw the corrected curve C_3 as shown in figures 4 and 5 in which, for any given temperature, $AB = CD$.

8.1.4 Express the results in the form of

- a) a plot showing the percentage change in height of the test piece (relative to its initial height) as a function of temperature during the period of rising temperature (see figure 5);
- b) a plot of the creep showing the percentage change in height of the test piece (relative to its initial height) as a function of time during the period of constant temperature (see figure 5);
- c) a table of the creep showing the percentage change in height of the test piece (relative to its initial height) at the moment when the constant temperature was reached and at intervals of 5 h thereafter;
- d) the total creep value between the 5th and the 25th hour of testing.

NOTE — If the material began to deform before the test temperature was reached, such deformation should be referred to in the test report. This deformation is the percentage change in the height of the test piece (relative to its initial height), which occurs between the temperature where the maximum on the expansion curve was observed and the test temperature.

8.2 Load applied at test temperature

In a test in which the load is applied after the test piece has been maintained for a period at constant temperature, express the creep results in the following form, for which a correction for the expansion of the alumina tube is not required :

- a) a plot of the creep showing the percentage change in height of the test piece (relative to its initial height) as a function of time during the period when the load was applied;
- b) a table of the creep showing the percentage change in height of the test piece (relative to its initial height) at the moment when the load was applied and at intervals of 5 h thereafter;
- c) the total creep value between the 5th and the 25th hour of testing.

9 Test report

The test report shall include the following particulars :

- a) the name of the testing establishment;
- b) the date of the test;

c) a reference to this International Standard, i.e., "Determination of creep in compression in accordance with ISO 3187";

d) the description of the material tested (for example manufacturer, type, batch number, etc.);

e) if applicable, the number of tests performed on each item (brick);

f) the position and orientation of the test piece in the original brick or shape;

g) the type of furnace used;

h) the nature of the atmosphere in the furnace (if other than air);

i) the heating rates employed;

j) the test temperature;

k) whether the load was applied when the furnace was switched on or after a period of exposure to the test temperature;

l) if applicable, the duration of exposure to the test temperature before the load was applied;

m) the load applied;

n) the period for which the load was applied, or the percentage deformation at which the test was terminated;

o) the results of the test in accordance with 8.1.4 or 8.2.

iTeh STANDARD PREVIEW
(standards.iteh.ai)

ISO 3187:1989

<https://standards.iteh.ai/catalog/standards/sist/57e4dfdf-de35-445b-b93c-c6fed36e4e8a/iso-3187-1989>

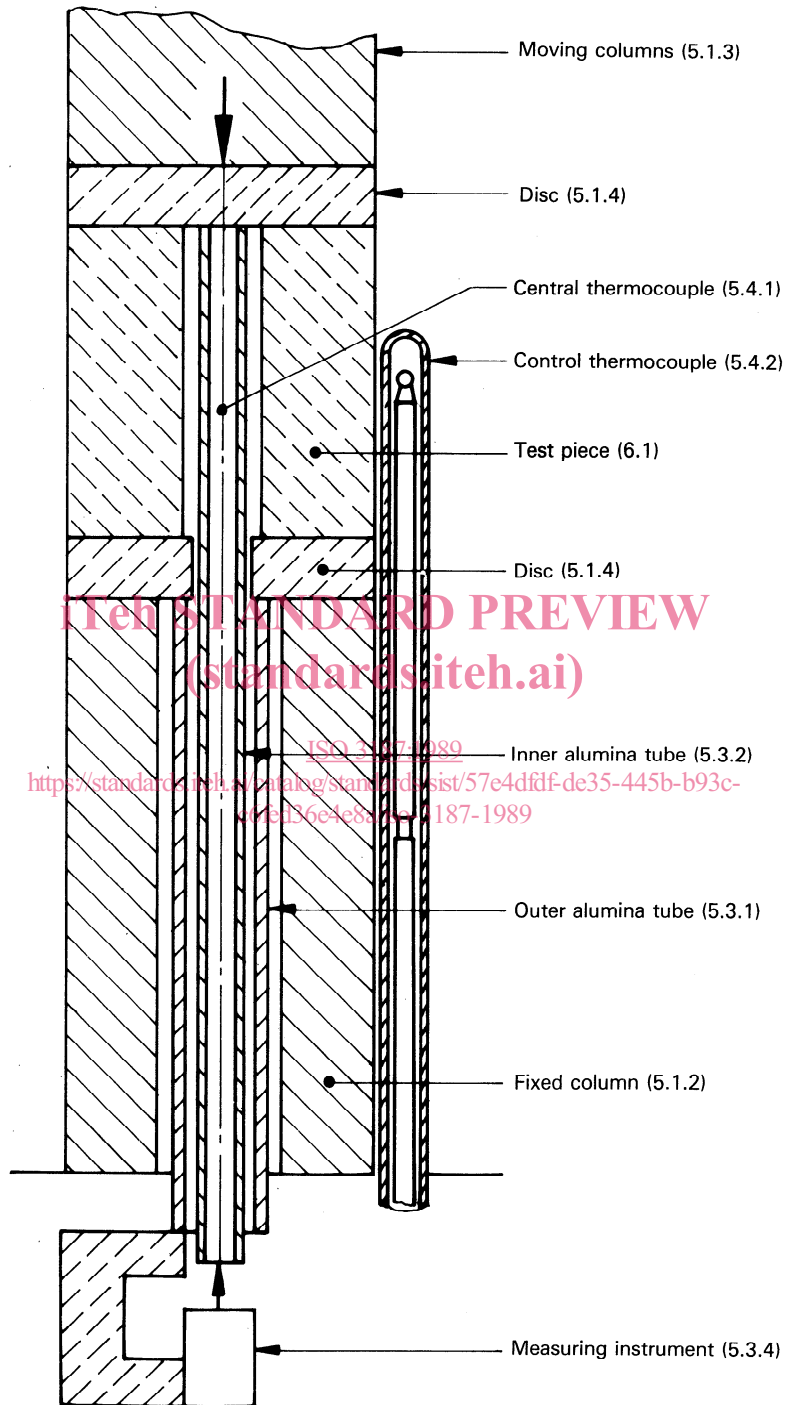

Figure 1 – Test apparatus – Measuring instrument below test piece

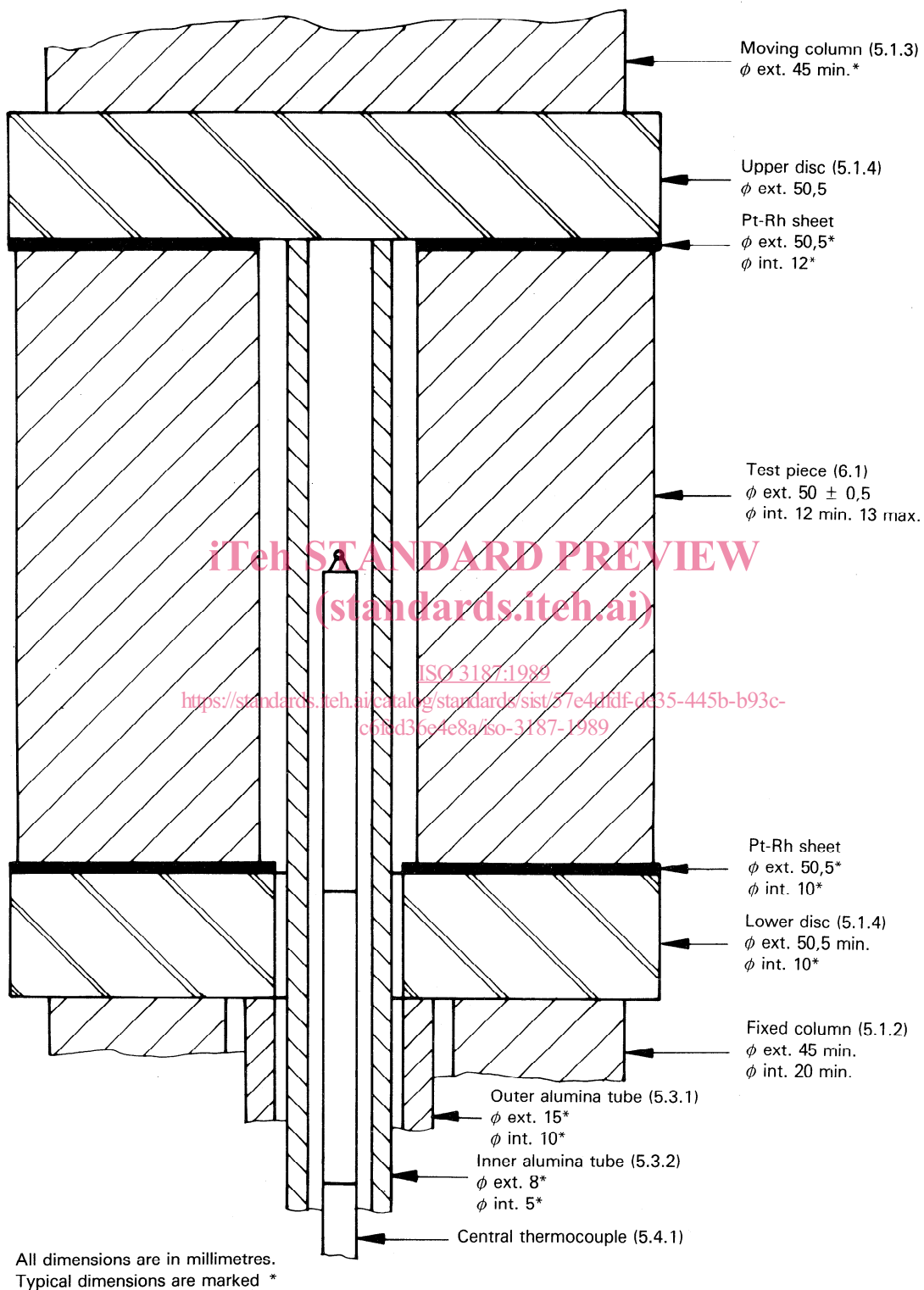

Figure 2 — Preferred arrangement of test piece, columns, discs and tubes

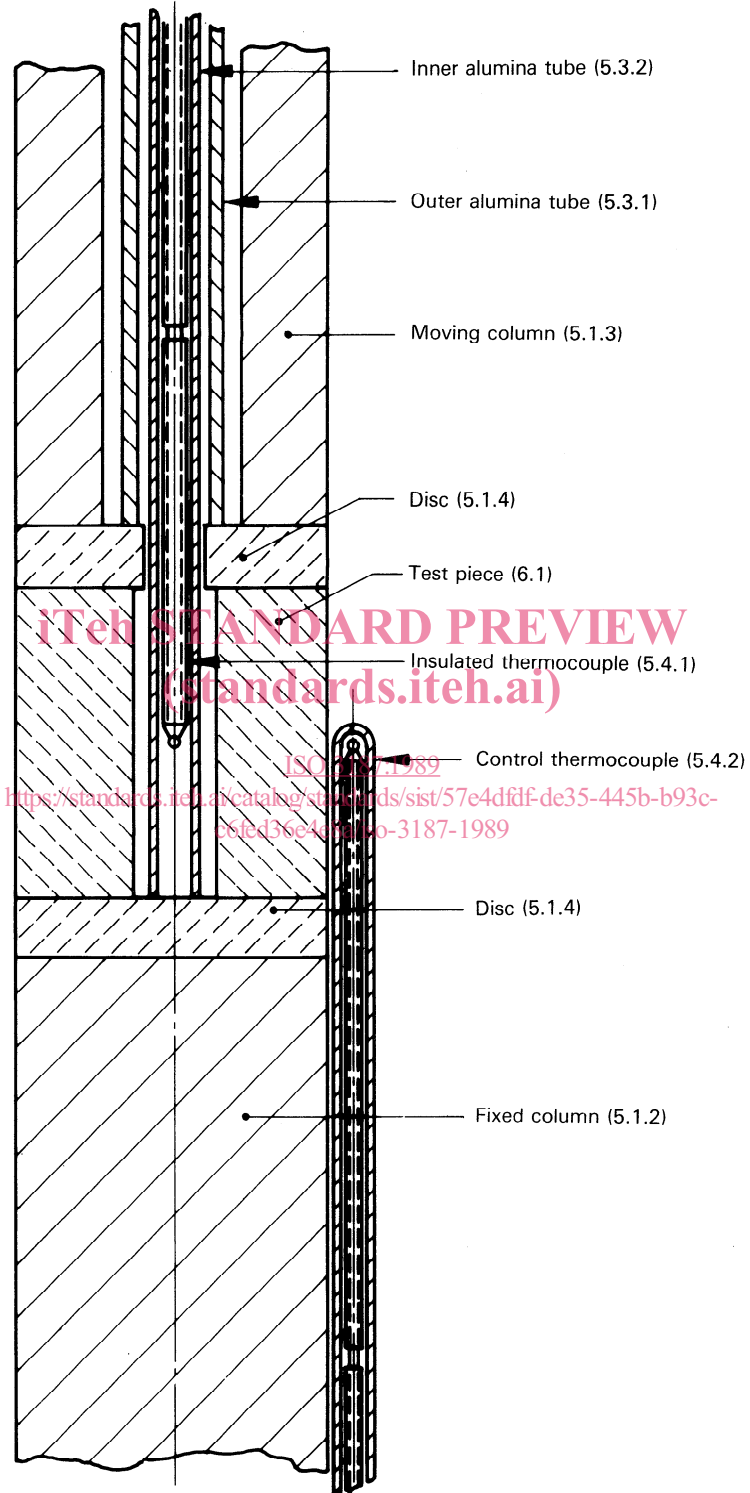

Figure 3 – Test apparatus – Measuring instrument above test piece