



FINAL DRAFT International Standard

Fibre reinforced plastics — Telescopic ladder — Requirements and test methods

*Plastiques renforcés de fibres de verre — Échelle télescopique —
Exigences et méthodes d'essai*

ISO/FDIS 11671

ISO/TC 61/SC 11

Secretariat: JISC

Voting begins on:
2024-07-08

Voting terminates on:
2024-09-02

Standards
(<https://standards.iteh.ai>)
Document Preview

<https://standards.iteh.ai>
ISO/FDIS 11671

<https://standards.iteh.ai/catalog/standards/iso/0e076f51-9e90-4169-be39-8c5385663c8a/iso-fdis-11671>

RECIPIENTS OF THIS DRAFT ARE INVITED TO SUBMIT, WITH THEIR COMMENTS, NOTIFICATION OF ANY RELEVANT PATENT RIGHTS OF WHICH THEY ARE AWARE AND TO PROVIDE SUPPORTING DOCUMENTATION.

IN ADDITION TO THEIR EVALUATION AS BEING ACCEPTABLE FOR INDUSTRIAL, TECHNOLOGICAL, COMMERCIAL AND USER PURPOSES, DRAFT INTERNATIONAL STANDARDS MAY ON OCCASION HAVE TO BE CONSIDERED IN THE LIGHT OF THEIR POTENTIAL TO BECOME STANDARDS TO WHICH REFERENCE MAY BE MADE IN NATIONAL REGULATIONS.

iTeh Standards
(<https://standards.iteh.ai>)
Document Preview

[ISO/FDIS 11671](https://standards.iteh.ai/catalog/standards/iso/0e076f51-9e90-4169-be39-8c5385663c8a/iso-fdis-11671)

<https://standards.iteh.ai/catalog/standards/iso/0e076f51-9e90-4169-be39-8c5385663c8a/iso-fdis-11671>



COPYRIGHT PROTECTED DOCUMENT

© ISO 2024

All rights reserved. Unless otherwise specified, or required in the context of its implementation, no part of this publication may be reproduced or utilized otherwise in any form or by any means, electronic or mechanical, including photocopying, or posting on the internet or an intranet, without prior written permission. Permission can be requested from either ISO at the address below or ISO's member body in the country of the requester.

ISO copyright office
CP 401 • Ch. de Blandonnet 8
CH-1214 Vernier, Geneva
Phone: +41 22 749 01 11
Email: copyright@iso.org
Website: www.iso.org

Published in Switzerland

Contents

	Page
Foreword	v
Introduction	vi
1 Scope	1
2 Normative references	1
3 Terms and definitions	2
4 Technical requirement	4
4.1 Functional dimension.....	4
4.2 Total load.....	4
4.3 Materials.....	5
4.4 Protection.....	5
4.5 Surface finish.....	5
4.6 Hinges (turning points).....	5
4.7 Opening restraints.....	6
4.8 Rung/steps.....	6
4.9 Ladder feet.....	6
4.10 Top of leaning ladders.....	6
4.11 Locking of the rung/step sections.....	6
5 Testing methods	6
5.1 Appearance check.....	6
5.2 Dimension check.....	6
5.3 Marking durability test.....	6
5.4 Mechanical performance test.....	7
5.4.1 General requirements.....	7
5.4.2 Drop test.....	7
5.4.3 Strength test of stiles.....	7
5.4.4 Bending test of stile.....	9
5.4.5 Lateral deflection test of the ladder.....	10
5.4.6 Bottom stile ends test.....	11
5.4.7 Vertical load on rung/steps.....	12
5.4.8 Torsion test of rung/steps.....	13
5.4.9 Pull out test of rung/step.....	14
5.4.10 Test of opening restraints and hinges of standing ladders.....	15
5.4.11 Base slip test for leaning ladders.....	15
5.4.12 Test of locking mechanism.....	17
5.4.13 Cyclic test of hinge joints.....	18
5.4.14 Feet pull test.....	19
5.4.15 Asymmetrical bending test.....	19
5.4.16 Durability test for standing ladders.....	21
5.4.17 Opening and closing cycle test.....	24
5.5 Aging test.....	24
5.5.1 Principle.....	24
5.5.2 Preparation of the samples.....	24
5.5.3 Procedure.....	24
6 Marking, user instruction, packaging, transport and storage	25
6.1 Marking.....	25
6.2 User instruction.....	25
6.3 Packaging.....	26
6.4 Transport.....	26
6.5 Storage.....	26
Annex A (informative) Inspection rules	27
Annex B (normative) Test sequence	28

iTeh Standards
(<https://standards.iteh.ai>)
Document Preview

[ISO/FDIS 11671](https://standards.iteh.ai/catalog/standards/iso/0e076f51-9e90-4169-be39-8c5385663c8a/iso-fdis-11671)

<https://standards.iteh.ai/catalog/standards/iso/0e076f51-9e90-4169-be39-8c5385663c8a/iso-fdis-11671>

Foreword

ISO (the International Organization for Standardization) is a worldwide federation of national standards bodies (ISO member bodies). The work of preparing International Standards is normally carried out through ISO technical committees. Each member body interested in a subject for which a technical committee has been established has the right to be represented on that committee. International organizations, governmental and non-governmental, in liaison with ISO, also take part in the work. ISO collaborates closely with the International Electrotechnical Commission (IEC) on all matters of electrotechnical standardization.

The procedures used to develop this document and those intended for its further maintenance are described in the ISO/IEC Directives, Part 1. In particular, the different approval criteria needed for the different types of ISO document should be noted. This document was drafted in accordance with the editorial rules of the ISO/IEC Directives, Part 2 (see www.iso.org/directives).

ISO draws attention to the possibility that the implementation of this document may involve the use of (a) patent(s). ISO takes no position concerning the evidence, validity or applicability of any claimed patent rights in respect thereof. As of the date of publication of this document, ISO had not received notice of (a) patent(s) which may be required to implement this document. However, implementers are cautioned that this may not represent the latest information, which may be obtained from the patent database available at www.iso.org/patents. ISO shall not be held responsible for identifying any or all such patent rights.

Any trade name used in this document is information given for the convenience of users and does not constitute an endorsement.

For an explanation of the voluntary nature of standards, the meaning of ISO specific terms and expressions related to conformity assessment, as well as information about ISO's adherence to the World Trade Organization (WTO) principles in the Technical Barriers to Trade (TBT), see www.iso.org/iso/foreword.html.

This document was prepared by Technical Committee ISO/TC 61, *Plastics*, Subcommittee SC 11, *Products*.

Any feedback or questions on this document should be directed to the user's national standards body. A complete listing of these bodies can be found at www.iso.org/members.html.

<https://standards.iteh.ai>
ISO/FDIS 11671

<https://standards.iteh.ai/catalog/standards/iso/0e076f51-9e90-4169-be39-8c5385663c8a/iso-fdis-11671>

Introduction

This document relates only to telescopic ladders made of fibre-reinforced plastic materials. Therefore, the test methods and technical requirements for the aging performance of the ladders are increased.

This document is applicable to different countries and regions in the world, considering the weight difference between people in different countries and regions, and also in order to reduce the weight of the ladder and more convenient to carry, so the maximum total weight of the ladder is divided into two grades: 100 kg and 150 kg.

iTeh Standards (<https://standards.itih.ai>) Document Preview

[ISO/FDIS 11671](https://standards.itih.ai/catalog/standards/iso/0e076f51-9e90-4169-be39-8c5385663c8a/iso-fdis-11671)

<https://standards.itih.ai/catalog/standards/iso/0e076f51-9e90-4169-be39-8c5385663c8a/iso-fdis-11671>

Fibre reinforced plastics — Telescopic ladder — Requirements and test methods

1 Scope

This document specifies the terms and definitions, technical requirements, test methods and inspection rules for telescopic ladders made of fibre-reinforced plastics.

This document applies to the manufacture, selection, inspection and use of telescopic ladders made of fibre-reinforced plastics.

NOTE 1 [Annex A](#) provides guidance for inspection rules of the telescopic ladders.

NOTE 2 [Annex B](#) classifies all the tests covered in this document into 8 test blocks and specifies the sequence of tests within the same test block.

It does not apply to ladders with a length over 5 m.

NOTE 2 Ladders with a length over 5 m can use this document as a reference.

The scope of this document does not relate to the “live working” and “explosive atmospheres”.

2 Normative references

The following documents are referred to in the text in such a way that some or all of their content constitutes requirements of this document. For dated references, only the edition cited applies. For undated references, the latest edition of the referenced document (including any amendments) applies.

ISO 179-1, *Plastics — Determination of Charpy impact properties — Part 1: Non-instrumented impact test*

ISO 4892-2:2013, *Plastics — Methods of exposure to laboratory light sources — Part 2: Xenon-arc lamps*

ISO 7599, *Anodizing of aluminium and its alloys — Method for specifying decorative and protective anodic oxidation coatings on aluminium*

ISO 14125, *Fibre-reinforced plastic composites — Determination of flexural properties*

ISO 14644-1, *Cleanrooms and associated controlled environments — Part 1: Classification of air cleanliness by particle concentration*

ISO 14713-2, *Zinc coatings — Guidelines and recommendations for the protection against corrosion of iron and steel in structures — Part 2: Hot dip galvanizing*

ISO 16293-2, *Glass in building — Basic soda lime silicate glass products — Part 2: Float glass*

IEC 62321-3-1, *Determination of certain substances in electrotechnical products — Part 3-1: Screening test methods — Screening of electrotechnical products for lead, mercury, cadmium, total chromium and total bromine using X-ray fluorescence spectrometry*

IEC 62321-4, *Determination of certain substances in electrotechnical products — Part 4: Determination of mercury in polymers, metals and electronics by CV-AAS, CV-AFS, ICP-OES and ICP-MS*

EN 59, *Glass reinforced plastics — Determination of indentation hardness by means of a Barcol hardness tester*

EN 131-3, *Ladders — Part 3: Marking and user instructions*

EN 10088-2, *Stainless steels — Part 2: Technical delivery conditions for sheet/plate and strip of corrosion resisting steels for general purposes*

3 Terms and definitions

For the purposes of this document, the following terms and definitions apply.

ISO and IEC maintain terminological databases for use in standardization at the following addresses:

- ISO Online browsing platform: available at <https://www.iso.org/obp>
- IEC Electropedia: available at <https://www.electropedia.org/>

3.1

telescopic ladder

ladder consisting of three or more rung/step sections with telescopic stiles

Note 1 to entry: See [Figure 1](#).

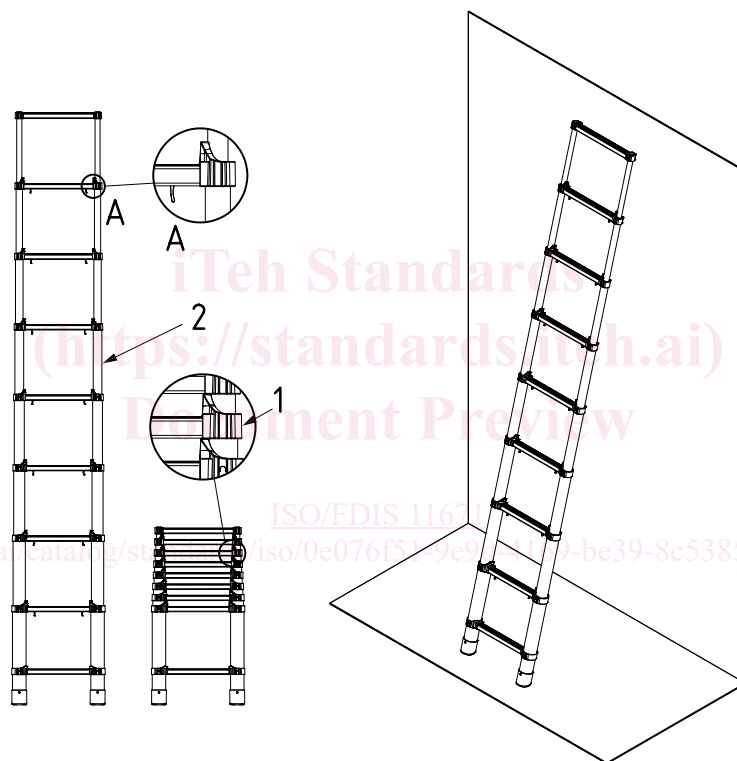

Key

- 1 bracket
- 2 stile
- A rung/step section locking mechanism

Figure 1 — Example of structure of a telescopic ladder

3.2

free-standing telescopic ladder

ladder (with rungs or steps) which has its own support with opening restraints.

Note 1 to entry: See [Figure 2](#).

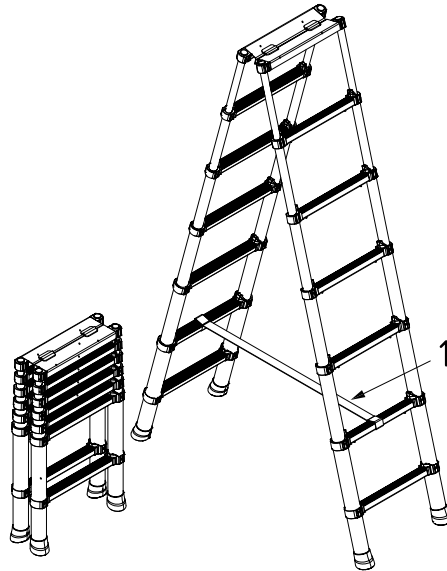

Key

1 one of the opening restraints

Figure 2 — Example of structure of free-standing telescopic ladder

3.3

rung/step section

section of ladder that consists of one rung/step connected to two telescopic stiles

3.4

bracket

part that attaches the rung/step to the stile.

Note 1 to entry: See [Figure 1](#).

3.5

locking indicator

mechanism or part that indicates that one rung/step section or part of one rung/step section is locked/unlocked

3.6

rung/step section locking mechanism

mechanism that locks a rung/step section

Note 1 to entry: See [Figure 1](#).

3.7

locking pin

part that locks each rung/step section and that is engaged when the locking mechanism is locked

3.8

protection system against squeezing

mechanism or part that minimizes the risk of squeezing when the ladder is shortened

3.9

release function

function which releases the locking mechanism

3.10

ascendable side

part of the ascending leg consisting only of fully extended rung/step sections

3.11

storage position

position where none of the rung/step sections are extended

3.1.12

acceptance test

contractual test to prove to the customer that the item meets certain conditions of its specification

3.1.13

type test

conformity test made on one or more items representative of the production

4 Technical requirement

4.1 Functional dimension

The size mark of the telescopic ladder is shown in Figure 3, and the numerical relationship between dimensions is shown in Table 1. It shall meet the requirements in Table 1.

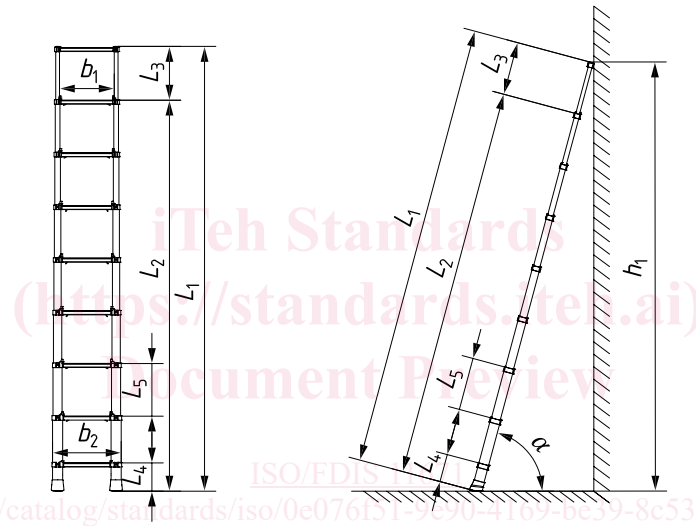

Figure 3 — Dimension of telescopic ladder

Table 1 — Functional sizes

Dimensions in millimetres

	b_1	b_2 where $L_1 < 3\ 000$	b_2 Where $L_1 > 3\ 000$	L_3 and L_4	L_5	α
min.	280	340	$b_1 + 0,1 \times L_1$	$0,5 L_5$	250	65°
max.	—	— ^a	— ^a	$L_5 + 15$	300	75°

^a The dimension b_2 for leaning ladders may be limited to a maximum of 1 200 mm at the discretion of the manufacturer.

4.2 Total load

The telescopic ladder is divided into two grades: I and II. The maximum total load that telescopic ladders can bear are shown in Table 2.

Table 2 — Maximum total load table

Grade	m ^a (kg)
I	100
II	150
^a Total weight of the operator and its load.	

NOTE 1 It takes into account differences in height and weight in different parts of the world. The maximum total load is equal to the sum of the weight of the personnel and the weight of the tools carried.

NOTE 2 Ladders are intended to be used by one person at a time, however this excludes any person footing (stabilizing) the ladder.

4.3 Materials

The main part of the ladder (stiles, rung/step) should be made of fibre-reinforced engineering plastics. It shall be protected against penetration of water and dirt. The surface shall be smooth. The fibre shall be embedded. The Barcol hardness shall be at least 35 in accordance with EN 59.

The content of heavy metals such as lead, cadmium, mercury and hexavalent chromium in non-metallic material parts shall meet the requirements of IEC 62321-4 and IEC 62321-3-1.

4.4 Protection

Screws and nuts shall be secured against loosening.

It shall be impossible to separate rung/step sections without using an adapted tool.

The unlocking and sliding in of the ladder shall be possible in a safe way. Squeezing between the rung/steps is avoided when the ladder is used in accordance to the user instructions.

If only the stopper is used to protect against squeezing between the steps, the distance between the block and the position where the user's hand is placed when the telescopic ladder is recovered as recommended by the manufacturer shall not be less than 80 mm.

4.5 Surface finish

In order to avoid injuries, accessible edges, corners, and protruding parts shall be free of burrs, for example chamfered or rounded.

The metal parts of the ladder shall be smooth and flat, with chamfered edges and no sharp corners.

At least the following anti-corrosion treatment shall be carried out:

- surface anodization for aluminium alloy, which meets the requirements of ISO 7599;
- galvanization for ferrous metal which meets the requirements of ISO 14713-2.

Rotating elements shall be made of stainless steel.

4.6 Hinges (turning points)

The joints shall reliability connect the planes of the double rung/step ladders.

The hinge pin shall be secured against unintentional loosening. Pins shall have at least the same.

Strength as M 6 (5,3 mm) pins of steel 8,8. If the pin has several shearing points (piano hinge) there is no restriction as to the hinge pin diameter.

The hinges shall satisfy the tests according to [5.4.10](#).