



Designation: E 1681 – 99^{ε1}

Standard Test Method for Determining Threshold Stress Intensity Factor for Environment-Assisted Cracking of Metallic Materials¹

This standard is issued under the fixed designation E 1681; the number immediately following the designation indicates the year of original adoption or, in the case of revision, the year of last revision. A number in parentheses indicates the year of last reapproval. A superscript epsilon (ϵ) indicates an editorial change since the last revision or reapproval.

^{ε1} NOTE—Committee and Subcommittee jurisdictions were editorially revised in April 2000.

1. Scope

1.1 This test method covers the determination of the environment-assisted cracking threshold stress intensity factor parameters, K_{IEAC} and K_{EAC} , for metallic materials from constant-force testing of fatigue precracked beam or compact fracture specimens and from constant-displacement testing of fatigue precracked bolt-load compact fracture specimens.

1.2 This test method is applicable to environment-assisted cracking in aqueous or other aggressive environments.

1.3 Materials that can be tested by this test method are not limited by thickness or by strength as long as specimens are of sufficient thickness and planar size to meet the size requirements of this test method.

1.4 A range of specimen sizes with proportional planar dimensions is provided, but size may be variable and adjusted for yield strength and applied force. Specimen thickness is a variable independent of planar size.

1.5 Specimen configurations other than those contained in this test method may be used, provided that well-established stress intensity calibrations are available and that specimen dimensions are of sufficient size to meet the size requirements of this test method during testing.

1.6 *This standard does not purport to address all of the safety concerns, if any, associated with its use. It is the responsibility of the user of this standard to establish appropriate safety and health practices and determine the applicability of regulatory limitations prior to use.*

2. Referenced Documents

2.1 ASTM Standards:

D 1141 Specification for Substitute Ocean Water²

E 8 Methods for Tension Testing of Metallic Materials³

E 399 Test Method for Plane-Strain Fracture Toughness of Metallic Materials³

E 647 Test Method for Measurement of Fatigue Crack Growth Rates³

E 1823 Terminology Relating to Fatigue and Fracture Testing³

G 1 Practice for Preparing, Cleaning, and Evaluating Corrosion Test Specimens⁴

G 5 Standard Reference Method for Making Potentiostatic and Potentiodynamic Anodic Polarization Measurements⁴

G 15 Terminology Relating to Corrosion and Corrosion Testing⁴

3. Terminology

3.1 Definitions:

3.1.1 For definitions of terms relating to fracture testing used in this test method, refer to Terminology E 1823.

3.1.2 For definitions of terms relating to corrosion testing used in this test method, refer to Terminology G 15.

3.1.3 *stress-corrosion cracking (SCC)*—a cracking process that requires the simultaneous action of a corrodent and sustained tensile stress.

3.1.4 *stress intensity factor threshold for plane strain environment-assisted cracking ($K_{IEAC}[FL^{-3/2}]$)*—the highest value of the stress intensity factor (K) at which crack growth is not observed for a specified combination of material and environment and where the specimen size is sufficient to meet requirements for plane strain as described in Test Method E 399.

3.1.5 *stress intensity factor threshold for environment-assisted cracking ($K_{EAC}[FL^{-3/2}]$)*—the highest value of the stress intensity factor (K) at which crack growth is not observed for a specified combination of material and environment and where the measured value may depend on specimen thickness.

3.1.6 *physical crack size ($a_p[L]$)*—the distance from a reference plane to the observed crack front. This distance may represent an average of several measurements along the crack

¹ This test method is under the jurisdiction of ASTM Committee E-8 on Fatigue and Fracture and is the direct responsibility of Subcommittee E08.06 on Crack Growth Behavior.

Current edition approved April 10, 1999. Published August 1999. Originally published as E 1681 - 95. Last previous edition E 1681 - 95.

² *Annual Book of ASTM Standards*, Vol 11.02.

³ *Annual Book of ASTM Standards*, Vol 03.01.

⁴ *Annual Book of ASTM Standards*, Vol 03.02.

front. The reference plane depends on the specimen form, and it is normally taken to be either the boundary or a plane containing either the loadline or the centerline of a specimen or plate. The reference plane is defined prior to specimen deformation.

3.1.7 *original crack size* ($a_o[L]$)—the physical crack size at the start of testing.

3.1.8 *original uncracked ligament* ($b_o[L]$)—distance from the original crack front to the back edge of the specimen ($b_o = W - a_o$).

3.1.9 *specimen thickness* ($B[L]$)—the side-to-side dimension of the specimen being tested.

3.1.10 *tensile strength* ($\sigma_{TS} [FL^{-2}]$)—the maximum tensile stress that a material is capable of sustaining. Tensile strength is calculated from the maximum force during a tension test carried to rupture and the original cross-section area of the specimen.

3.2 *Definitions of Terms Specific to This Standard:*

3.2.1 *environment-assisted cracking* (EAC)—a cracking process in which the environment promotes crack growth or higher crack growth rates than would occur without the presence of the environment.

3.2.2 *normalized crack size* (a/W)—the ratio of crack size, a , to specimen width, W . Specimen width is measured from a reference position such as the front edge in a bend specimen or the loadline in the compact specimen to the back edge of the specimen.

3.2.3 *yield strength* ($\sigma_{YS} [FL^{-2}]$)—the stress at which a material exhibits a specific limiting deviation from the proportionality of stress to strain. This deviation is expressed in terms of strain.

NOTE 1—In this test method, the yield strength determined by the 0.2 % offset method is used.

3.2.4 *effective yield strength* ($\sigma_Y [FL^{-2}]$)—an assumed value of uniaxial yield strength that represents the influences of plastic yielding upon fracture test parameters. For use in this method, it is calculated as the average of the 0.2 % offset yield strength σ_{YS} , and the ultimate tensile strength, σ_{TS} , or

$$\sigma_Y = (\sigma_{YS} + \sigma_{TS}) / 2 \quad (1)$$

3.2.5 *notch length* ($a_n(L)$)—the distance from a reference plane to the front of the machined notch. The reference plane depends on the specimen form and normally is taken to be either the boundary or a plane containing either the loadline or the centerline of a specimen or plate. The reference plane is defined prior to specimen deformation.

4. Summary of Test Method

4.1 This test method involves testing of single-edge notched [SE(B)] specimens, compact [C(T)] specimens, or bolt-load compact [MC(W)] specimens, precracked in fatigue. The single-edge notched beam specimen is tested by dead weight loading. An environmental chamber is either attached to the specimen, or the specimen is contained within the chamber. The chamber must enclose the portion of the specimen where the crack tip is located. Prescribed environmental conditions must be established and maintained within the chamber at all times during the test.

4.1.1 Specimens shall be deadweight loaded or otherwise

held under constant force or held under constant displacement (defined in 6.2) for a prescribed length of time, during which failure by crack growth leading to fracture may or may not occur. K_{IEAC} and K_{EAC} are defined as the highest value of stress intensity factor at which neither failure nor crack growth occurs. The stress intensity factor (K) is calculated from an expression based on linear elastic stress analysis. To establish a suitable crack-tip condition for constant force tests, the stress-intensity level at which the fatigue precracking of the specimen is conducted is limited to a value substantially less than the measured K_{IEAC} or K_{EAC} values. For constant displacement tests, the stress-intensity level at which the fatigue precracking of the specimen is conducted is limited to the requirements of Test Method E 399. The validity of the K_{IEAC} value determined by this test method depends on meeting the size requirements to ensure plane strain conditions, as stated in Test Method E 399. The validity of the K_{EAC} value depends on meeting the size requirements for linear elastic behavior, as stated in the Test Method E 647.

4.1.2 This test method can produce information on the onset of environment-assisted crack growth. Crack growth rate information can be obtained after crack nucleation, but the method for obtaining this information is not part of this test method (1).⁵

4.2 The mechanisms of environment-assisted cracking are varied and complex. Measurement of a K_{EAC} or K_{IEAC} value for a given combination of material and environmental provides no insight into the particular cracking mechanism that was either operative or dominant. Two prominent theories of environment-assisted cracking are anodic reaction and hydrogen embrittlement (2). The data obtained from this test method may be interpreted by either theory of environment-assisted cracking.

4.3 Specimen thickness governs the proportions of plane strain and plane stress deformation local to the crack tip, along with the environmental contribution to cracking. Since these chemical and mechanical influences cannot be separated in some material/environment combinations, thickness must be treated as a variable. In this test method, however, the stress in the specimen must remain elastic. For these reasons, two threshold values of EAC are defined by this test method. The measurement of K_{IEAC} requires that the thickness requirements of plane strain constraint are met. The less restrictive requirements of K_{EAC} are intended for those conditions in which the results are a strong function of the thickness of the specimen and the application requires the testing of specimens with thickness representative of the application.

4.4 A variety of environmental (temperature, environment composition, and electrode potential, for example) and metallurgical (yield strength, alloy composition, and specimen orientation) variables affect K_{EAC} and K_{IEAC} .

5. Significance and Use

5.1 The parameters K_{EAC} or K_{IEAC} determined by this test method characterize the resistance to crack growth of a

⁵ The boldface numbers in parentheses refer to the list of references at the end of this standard.

material with a sharp crack in specific environments under loading conditions in which the crack-tip plastic region is small compared with the crack depth and the uncracked ligament. The less restrictive thickness requirements of K_{EAC} are intended for those conditions in which the results are a strong function of the thickness of the specimen and the application requires the testing of specimens with thickness representative of the application. Since the chemical and mechanical influences cannot be separated, in some material/environment combinations, the thickness must be treated as a variable. A K_{EAC} or K_{IEAC} value is believed to represent a characteristic measurement of environment-assisted cracking resistance in a precracked specimen exposed to an environment under sustained tensile loading. A K_{EAC} or K_{IEAC} value may be used to estimate the relationship between failure stress and defect size for a material under any service condition, where the combination of crack-like defects, sustained tensile loading and the same specific environment would be expected to occur. (Background information concerning the development of this test method can be found in Refs (3-18).

5.1.1 The apparent K_{EAC} or K_{IEAC} of a material under a given set of chemical and electrochemical environmental conditions is a function of the test duration. It is difficult to furnish a rigorous and scientific proof for the existence of a threshold (4, 5). Therefore, application of K_{EAC} or K_{IEAC} data in the design of service components should be made with awareness of the uncertainty inherent in the concept of a true threshold for environment-assisted cracking in metallic materials (6, 18). A measured K_{EAC} or K_{IEAC} value for a particular combination of material and environment may, in fact, represent an acceptably low rate of crack growth rather than an absolute upper limit for crack stability. Care should be exercised when service times are substantially longer than test times.

5.1.2 The degree to which force deviations from static tensile stress will influence the apparent K_{EAC} or K_{IEAC} of a material is largely unknown. Small-amplitude cyclic loading, well below that needed to produce fatigue crack growth, superimposed on sustained tensile loading was observed to significantly lower the apparent threshold for stress corrosion cracking in certain instances (7, 8). Therefore, caution should be used in applying K_{EAC} or K_{IEAC} data to service situations involving cyclic loading. In addition, since this standard is for static loading, small-amplitude cyclic loading should be avoided during testing.

5.1.3 In some material/environment combinations, the smaller the specimen, the lower the measured K_{EAC} value, while in other material/environment combinations the measured K_{IEAC} value will be the lowest value (5, 9, 10, 11, 12). If, for the material/environment combination of interest, it is not known which specimen size will result in the lower measured value, then it is suggested that the use of both specimen sizes should be considered; that is, specimens with thicknesses representative of the application and specimens in which the thickness meets the requirements (see 7.2.1) of a K_{IEAC} value.

5.1.3.1 The user may optionally determine and report a K_{EAC} value or a K_{IEAC} value. The specimen size validity requirements for a K_{EAC} value meet the size requirements

developed for Test Method E 647 to achieve predominately elastic behavior in the specimen. Test Method E 647 size requirements for compact specimens should be applied to both the compact specimen and the beam specimen. The specimen size validity requirements for a K_{IEAC} value meet the size requirements developed for plane strain conditions for Test Method E 399.

5.1.4 Evidence of environment-assisted crack growth under conditions that do not meet the validity requirements of 7.2 may provide an important indication of susceptibility to environmental cracking but cannot be used to determine a valid K_{EAC} value (14).

5.1.5 Environment-assisted cracking is influenced by both mechanical and electrochemical driving forces. The latter can vary with crack depth, opening, or shape and may not be uniquely described by the fracture mechanics stress intensity factor. As an illustrative example, note the strong decrease reported in K_{ISCC} ⁶ with decreasing crack size below 5 mm for steels in 3 % NaCl in water solution (15). Geometry effects on K similitude should be experimentally assessed for specific material/environment systems. Application modeling based on K_{EAC} similitude should be conducted with caution when substantial differences in crack and specimen geometry exist between the specimen and the component.

5.1.6 Not all combinations of material and environment will result in environment-assisted cracking. In general, susceptibility to aqueous stress-corrosion cracking decreases with decreasing material strength level. When a material in a certain environment is not susceptible to environment-assisted cracking, it will not be possible to measure K_{EAC} or K_{IEAC} . This method can serve the following purposes:

5.1.6.1 In research and development, valid K_{EAC} or K_{IEAC} data can quantitatively establish the effects of metallurgical and environmental variables on the environment-assisted cracking resistance of materials.

5.1.6.2 In service evaluation, valid K_{EAC} or K_{IEAC} data can be utilized to establish the suitability of a material for an application with specific stress, flaw size, and environmental conditions.

5.1.6.3 In acceptance and quality control specifications, valid K_{EAC} or K_{IEAC} data can be used to establish criteria for material processing and component inspection.

5.1.7 Test results will be affected by force relaxation in constant displacement bolt-loaded compact specimens for some material/environment conditions. For relatively low strength material, non-aggressive environments, or high test temperatures, force relaxation can occur independently from environment-assisted cracking. Significant force relaxation would make cracking results difficult to interpret. If force relaxation is suspected of influencing the data, the following trial specimen test is recommended. Test a trial specimen with all the test conditions of interest, except with no environment applied. Monitor the force on the sample using a bolt with an electronic load cell attached. Instrumented bolts of this type are commercially available. A force relaxation of more than 5 %

⁶ K_{ISCC} has been used in the literature as a special case of K_{IEAC} in which the crack growth is known to be due to the simultaneous action of a stress and a corrodent.

after 24 h indicates that the constant displacement test method may not be suitable for these test conditions, and a constant force test should be considered.

5.1.8 Residual stresses can have an influence on environment-assisted cracking. The effect can be significant when test specimens are removed from material in which complete stress relief is impractical, such as weldments, as-heat-treated materials, complex wrought parts, and parts with intentionally produced residual stresses. Residual stresses superimposed on the applied stress can cause the local crack-tip stress-intensity factor to be different from that calculated from externally applied forces or displacements. Irregular crack growth during precracking, such as excessive crack front curvature or out-of-plane crack growth, often indicates that residual stresses will affect the subsequent environment-assisted crack growth behavior. Changes in the zero-force value of crack-mouth-opening displacement as a result of precrack growth is another indication that residual stresses will affect the subsequent environment-assisted crack growth.

5.1.9 For bolt loaded specimens, the user should realize that material being tested at a non-ambient temperature may have a different displacement-to-force ratio from that at ambient temperature, and also the bolt material may have a different coefficient of thermal expansion from that of the material being tested. Care should be taken to minimize these effects.

6. Apparatus

6.1 Fixtures:

6.1.1 *Beam Specimens*—Specimens should be loaded with one end clamped in a stable rigid fixture and the other end clamped to a horizontal moment arm to which a force is applied. In a fixture of this type, the long axis of the specimen is placed horizontally with the notch opening upward. A schematic representation of a suitable loading fixture is given in Fig. 1. Note that limits are placed on the proximity of fixture contact points to the specimen notch and on the length of the moment arm. The fixture should have enough stiffness to ensure that moment arm deflection under force application is

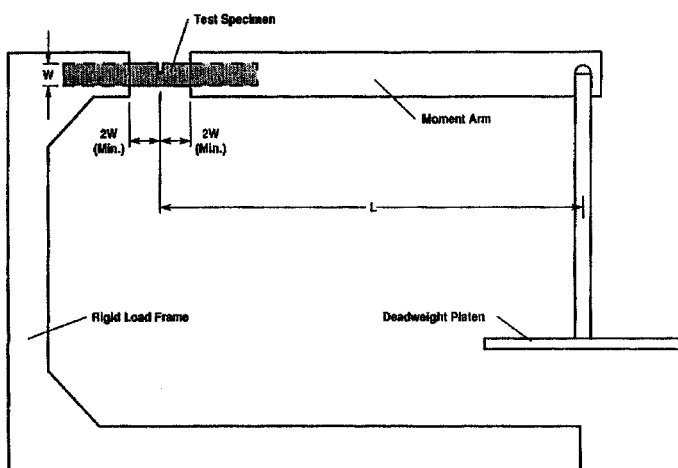

NOTE 1—The length of the moment arm (L) should be equal to or greater than $8W$

FIG. 1 Typical Configuration of a Dead-Weight Beam Loading Fixture

primarily caused by test specimen compliance. In situations in which a single loading fixture simultaneously accommodates multiple specimens, it is important that the loading fixture be rigid enough to minimize transmission of transient deflections from specimen to specimen through the fixture.

6.1.2 *Compact Specimens*—A loading clevis suitable for constant force testing of compact specimens is shown in Fig. 2. Both ends of the specimen are held in a clevis and loaded through pins to allow rotation of the specimen during testing. To provide rolling contact between the loading pins and the clevis holes, the holes are machined with small flats on the loading surface. Other clevis designs may be used if it can be demonstrated that they will accomplish the same result.

6.1.3 *Bolt-Load Compact Specimens*—A test arrangement suitable for constant-displacement testing of bolt-load compact specimens is shown in Fig. 3. The displacement is applied to the specimen containing a machined notch and fatigue precrack. The displacement is applied with a bolt tightened against a flattened pin and measured with an electronic crack-mouth-opening-displacement (CMOD) gage (see Test Method E 399). Reference marks on the face of the specimen on both sides of the notch may also be used to verify the CMOD measurement of the applied displacement. The gage is attached to the specimen using integral knife edges machined into the specimen or using knife edges affixed to the specimen. Other types of gages and attachments may be used if it can be demonstrated that they will accomplish the same result. It is recommended that, if possible, the bolt pin be isolated from the environment and that an electric insulator be used between the bolt and pin. For some test conditions, environmental isolation and electrical insulation may not be possible.

6.2 Displacement Application:

6.2.1 *Constant-Force Specimens*—Specimens must be deadweight loaded or loaded so that the force remains constant

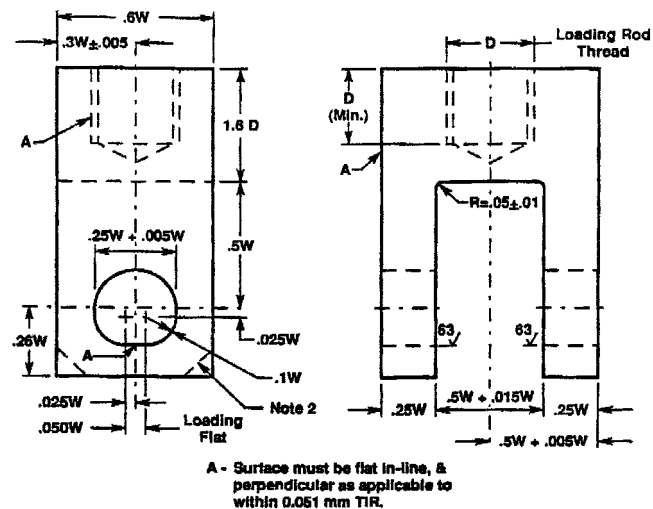

NOTE 1—Pin diameter = $0.24W (+0.000W/-0.005W)$. For Specimens with $\sigma_{vs} > 1379$ MPa the holes in the specimen and in the clevis may be $0.3W (+0.005W/-0.000W)$ and the pin diameter = $0.288W (+0.000W/-0.005W)$

NOTE 2—Corners of the clevis may be removed if necessary to accommodate a clip gage

FIG. 2 Tension Test Clevis Design

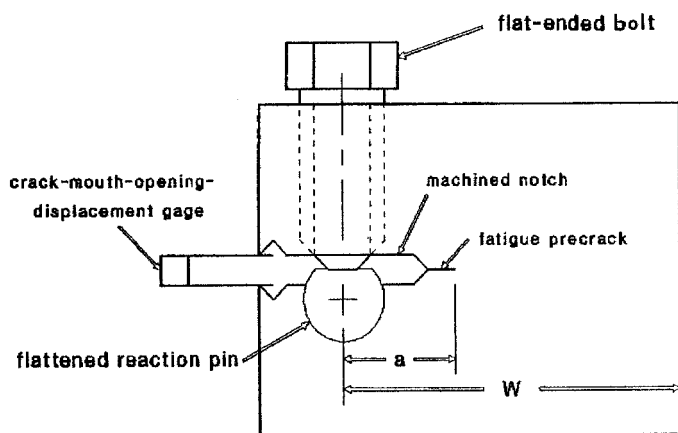

FIG. 3 Typical Test Arrangement for Constant Displacement K_{IEAC} Tests with Modified Bolt-Load Compact Specimen; $H/W = 0.486$

throughout the test. Weights or a servo-controlled actuator are suitable for this purpose. A means must be provided to accurately measure the force, including the weight of the moment arm and associated load train fixtures. This may be done by including an electronic load cell in the load train or by using calibrated weights. The force applied to the specimen must be known, with an accuracy of $\pm 1\%$ of the indicated reading. Overloads of more than 3% and repetitive force fluctuations of more than 1% must be avoided during the experiment. In addition, extraneous bending and torsional forces must be minimized (see 8.3).

6.2.2 *Constant Displacement Specimens*—The crack-mouth-opening-displacement applied to the bolt-load specimen must be known, with an accuracy of $\pm 1\%$ of the indicated reading. Overapplications of displacement of more than 5% and repetitive displacement fluctuations of more than 1% must be avoided during the experiment.

6.3 *Displacement Gauge*—It may be desirable to attach a displacement gage to a constant force specimen to detect crack growth during testing. It is required that a displacement gage be used with the constant displacement specimen to measure the amount of applied displacement (see 6.1.3). An electronic CMOD gage can provide a highly sensitive indicator of crack growth for this purpose (see Test Method E 399). However, when placed directly above an environmental chamber containing an aqueous solution for prolonged periods, corrosion may degrade CMOD gages. Also, the CMOD gage should not be allowed to come into direct contact with the solution to avoid possible galvanic action between the gage and the test specimen. A mechanical dial gage placed near the extremity of the moment arm also may be used to detect crack growth.

6.4 *Environmental Chamber*—It is important that the environmental chamber does not influence the test results either by modifying the environment or the electrochemical potential of the specimen. Influence of the environment chamber or the pressure of the environment should be accounted for in the calibration of the applied K value. The environmental chamber shall enclose the portion of the specimen that contains the crack tip. It shall be configured so that either the test specimen is the only metallic component in contact with the solution or the specimen is electrically isolated from any other metals in contact with the solution. Nonmetallic or corrosion resistant

materials are recommended for the environmental chamber. A sealant might be required between the specimen and the environmental chamber. Sealants selected must not alter the bulk solution chemistry of the test environment. It is recommended that the volume of the environmental chamber be large enough to contain at least 40 mL/cm^2 of specimen surface area exposed to the solution.⁷

6.5 *Potentiostatic Control*—Where potentiostatic control of the specimen is desired, an electrochemical cell is required (including an auxiliary electrode, such as platinum or graphite, and a reference electrode with specimen potential controlled by a potentiostat). Care must be taken to avoid ground loops and galvanic interference from the clamping and loading fixtures. Oxides on the specimen surface may hamper the achievement of the desired specimen potential. Under some conditions, it may be necessary to mask off a portion of the specimen surface so that proper potentiostatic control can be achieved. It is desirable to include apparatus for measuring and recording electrode potential and applied current (Reference Method G 5).

7. Specimen Configuration, Size, and Preparation

7.1 Specimen Configuration:

7.1.1 The recommended beam specimen configuration is shown in Fig. 4. It is recommended that $1 \leq W/B \leq 2$, provided that B , a_0 , and $W-a_0$ meet the validity criteria of 7.2. The specimen configuration shown in Fig. 4 does not include side grooves.⁸

NOTE 2—Caution should be exercised to avoid preferential crack growth near the side grooves when testing in more aggressive environments.

7.1.2 The recommended compact specimen configuration is shown in Fig. 5. The configuration does not include side grooves.⁸ For the determination of K_{IEAC} , it is recommended that $1 \leq W/B \leq 2$, provided that B , a_0 , and $W-a_0$ meet the validity criteria of 7.2.

7.1.3 The recommended bolt-load compact specimen configuration is shown in Fig. 6. The configuration does not

⁷ The ratio of the specimen free surface area, exposed to the test solution in the chamber, to the crack size affects the anode/cathode area and can affect the corrosion potential in the crack. The area external to the crack should be significantly greater than the crack area.

⁸ If crack growth rate information is to be obtained in addition to K_{IEAC} , side grooves may be desirable. Side grooves may promote straight fronted crack growth with some materials in some environments. Side groove depths with a total thickness reduction of 20% are suggested. Side groove root radii of less than 0.4 mm (0.016 in.) are suggested. Alternative methods to obtain crack growth rate information are available (see Test Method E 647) (1).

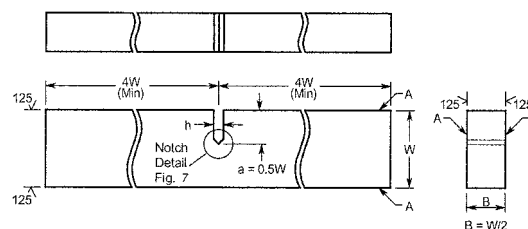

NOTE 1—A Surface Perpendicular and parallel within 0.001 W TIR

FIG. 4 Beam Specimen

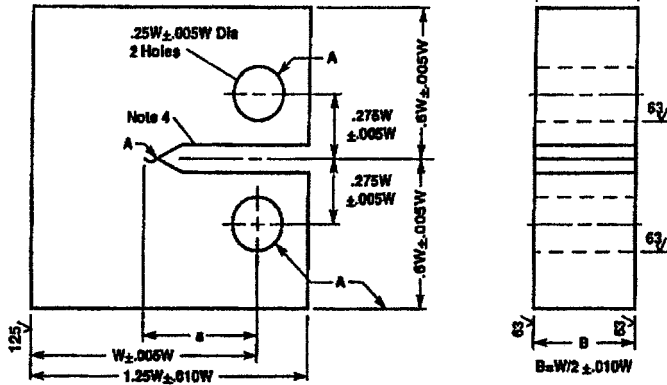

NOTE 1—A surface shall be perpendicular and parallel as applicable to within 0.002W TIR

NOTE 2—The intersection of the crack starter notch tips with the two specimen surfaces shall be equally distant from the top and bottom edges of the specimen within 0.005W

NOTE 3—Integral or attachable knife edges for clip gage attachment to the crack mouth may be used

NOTE 4—For starter notch and fatigue crack configuration see Fig. 7

FIG. 5 Standard Proportions and Tolerances for the Compact Specimen

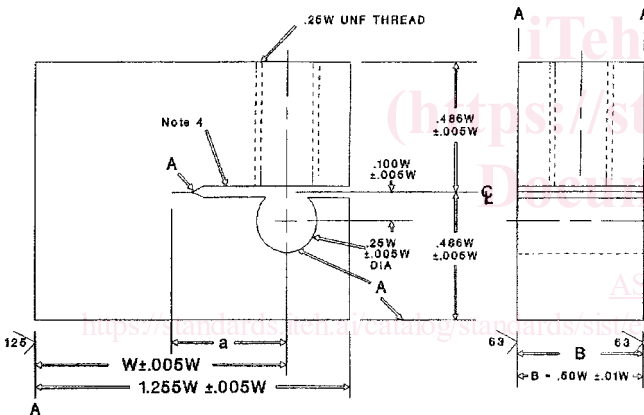

NOTE 1—A surfaces perpendicular and parallel as applicable to within 0.002W TIR.

NOTE 2—The intersection of the crack starter notch tips with the two specimen surfaces shall be equally distant from the top and bottom edges of the specimen within 0.005W.

NOTE 3—Integral or attachable knife edges for clip gage attachment to the crack mouth may be used.

NOTE 4—For starter notch and fatigue crack configuration see Fig. 7.

FIG. 6 Standard Configuration for the Modified Bolt-Load Compact Specimen; H/W = 0.486

include side grooves.⁸ While for the determination of K_{IEAC} , it is recommended that W/B is 2:1, a 1:1 ratio can also be used, provided that B, a, and W-a meet the validity criteria of 7.2.

7.1.4 Other specimen and loading configurations, for which well-established stress intensity calibrations are available, are acceptable as long as the specimen size requirements of 7.2 are met.

7.2 Specimen Size—For the results to be valid in accordance with this test method, it is required that the specimen be predominantly elastic in its behavior and that one or more of the following criteria be satisfied.

7.2.1 For the measurement of K_{IEAC} , it is required that B, a_0 , and $W-a_0$ equal or exceed the quantity $2.5 (K_{IEAC}/\sigma_{YS})^2$, where σ_{YS} is the yield strength of the material determined at the temperature of the K_{IEAC} experiment.

7.2.2 For the measurement of K_{EAC} , it is required that $W-a_0$ equal or exceed the quantity $(4/\pi)(K_{EAC}/\sigma_{YS})^2$. In this calculation, σ_{YS} may be replaced by σ_Y for high work hardening materials with an ultimate to yield strength ratio greater than 1.3. These requirements are consistent with those used in Test Method E 647.

7.2.3 For the beam and compact specimens, it is recommended that the crack length (total length of the machined notch plus the fatigue precrack) be between 0.45 and 0.55 W whenever possible. However, normalized crack length values, a/W , may range from 0.25 to 0.75 in extreme instances, provided the requirements of 9.3 are met.

7.2.4 For the bolt-load compact specimen, applied K values continuously decrease with increasing crack length so that large crack lengths can be used. It is recommended that the total crack length (total length of the machined notch plus the fatigue precrack and the crack growth) be between 0.30 and .95 W, provided the requirements of 8.8.2.5 are met.

7.3 Specimen Preparation:

7.3.1 The dimensional tolerances and surface finishes shown in Figs. 4-7 shall be followed in the specimen preparation.

7.3.2 Care should be taken in machining to prevent contamination of specimen and notch surfaces that are difficult or impossible to clean. An example of this is the copper deposit

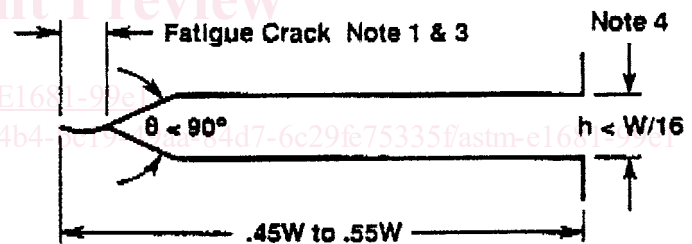

Straight Through Notch

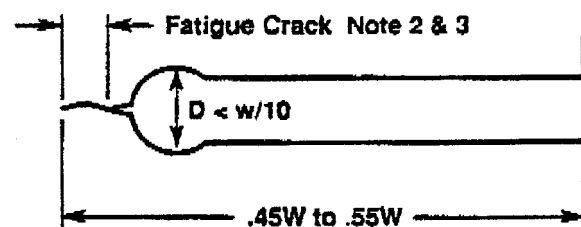

Slot Ending in Drilled Hole

NOTE 1—Fatigue crack extension on each surface of the specimen

NOTE 2—Fatigue crack extension on each surface of the specimen from the stress riser tipping the hole shall be at least 0.5 D or 1.3 mm whichever is larger

NOTE 3—Crack starter notch shall be perpendicular to the specimen surface and to the intended direction of crack propagation within $\pm 2^\circ$

NOTE 4—Notch width h need not be less than 1.6 mm

FIG. 7 Crack Starter Notch and Fatigue Crack Configurations