



Standard Specification for Protective Headgear Used in Horse Sports and Horseback Riding¹

This standard is issued under the fixed designation F1163; the number immediately following the designation indicates the year of original adoption or, in the case of revision, the year of last revision. A number in parentheses indicates the year of last reapproval. A superscript epsilon (ϵ) indicates an editorial change since the last revision or reapproval.

INTRODUCTION

Horse sports and horseback riding are sports with intrinsic hazards. It is recognized that it is not possible to write a protective headgear performance standard that will result in headgear that can protect against injury or death in all accidents. It is also recognized that serious injury or death can result from both low-energy and high-energy impacts, even when protective headgear is worn. It is further recognized that protective headgear must be acceptable to the user and to the regulating associations or agencies requiring its use. Acknowledging these limitations, this specification was developed using resources in medical, scientific, mechanical engineering, human factors, and biomechanical fields.

This specification incorporates many aspects of other recognized headgear performance standards. This specification draws from work done by others where appropriate for this specification. These standards may be referenced. It should be noted that this specification specifies a laboratory test of completed headgear to measure its ability to reduce head acceleration when impacting various shaped objects. It is known that headgear that performs well under this specification will mitigate head injury in actual use within its design limits.

1. Scope

1.1 This specification covers minimum performance criteria and describes test methods for protective headgear for use in horse sports and horseback riding.

1.2 It is not the intention of this specification to bar from consideration materials of improved quality or performance not known at the time of development of this specification.

1.3 All testing and requirements of this specification shall be in accordance with Test Methods F1446, except where noted herein.

1.4 The values stated in SI units are to be regarded as the standard.

1.5 The values stated in SI units are to be regarded as standard. No other units of measurement are included in this standard.

1.6 *This standard does not purport to address all of the safety concerns, if any, associated with its use. It is the*

responsibility of the user of this standard to establish appropriate safety and health practices and determine the applicability of regulatory limitations prior to use.

2. Referenced Document

2.1 *ASTM Standards:*²

F1446 Test Methods for Equipment and Procedures Used in Evaluating the Performance Characteristics of Protective Headgear

3. Terminology

3.1 *Definitions*—The terms used in this specification are defined in accordance with Test Methods F1446.

3.2 *Definitions of Terms Specific to This Standard:*

3.2.1 *cradle, n*—headband or other head-fitting device and those internal parts of the headgear in contact with the head.

3.2.2 *drawlace, n*—lace used for making adjustments to the fit of the cradle on the wearer's head.

¹ This specification is under the jurisdiction of ASTM Committee F08 on Sports Equipment, Playing Surfaces, and Facilities and is the direct responsibility of Subcommittee F08.53 on Headgear and Helmets.

Current edition approved March 1, 2013. Published March 2013. Originally approved in 1988. Last previous edition approved in 2011 as F1163 – 04a (2011). DOI: 10.1520/F1163-13.

² For referenced ASTM standards, visit the ASTM website, www.astm.org, or contact ASTM Customer Service at service@astm.org. For *Annual Book of ASTM Standards* volume information, refer to the standard's Document Summary page on the ASTM website.

4. Headforms

4.1 Headforms to be used in this specification are in accordance with the section on Apparatus of Test Methods F1446. The appropriate size headform shall be selected (see definition of headform size selection in the Terminology section of Test Methods F1446) for the helmet to be tested.

4.2 Test headforms used in this specification shall use the variable mass drop assembly configuration for impact testing as specified in the definition of test headforms in the terminology section and in Table 2 of Test Methods F1446.

5. Anvils and Impact Velocities

5.1 Anvils to be used for impact tests in this specification are the flat anvil described in the section and figure on Flat Anvil of Test Methods F1446, and the equestrian hazard anvil described in Fig. 1 of this specification. The circular portion of the equestrian hazard anvil shall have a radius of 66.7 ± 0.5 mm, with facial surfaces inclined at an angle of $45 \pm 2^\circ$. The edge rail at the intersection of the facial surfaces shall have a radius of 0.4 mm maximum.

5.2 The helmet shall be dropped onto the flat anvil from a theoretical drop height of 1.8 m to achieve an impact velocity of $6.0 \text{ m/s} \pm 3\%$.

5.3 The helmet shall be dropped onto the equestrian hazard anvil from a theoretical drop height of 1.3 m to achieve an impact velocity of $5.0 \text{ m/s} \pm 3\%$.

5.4 The impact velocity shall be measured during the last 40 mm of free-fall for each test and shall be within $\pm 3\%$ of the velocities specified in 5.2 and 5.3.

6. General Requirements and Marking

6.1 Select the appropriate reference headform in accordance with the definition of headform size selection in the Terminology section of Test Methods F1446.

6.2 Position the helmet in accordance with the section on Test Procedures of Test Methods F1446.

6.3 All helmets shall meet the requirements of the sections on Configuration, Materials, and Internal Projection of Test Methods F1446.

6.3.1 All reporting shall be described in the section on Reporting of Test Methods F1446.

6.3.2 Use the method described in the section on Reference Marking of Test Methods F1446.

6.4 Maintaining the force and position described in this section, draw the test line on the outer surface of the helmet as

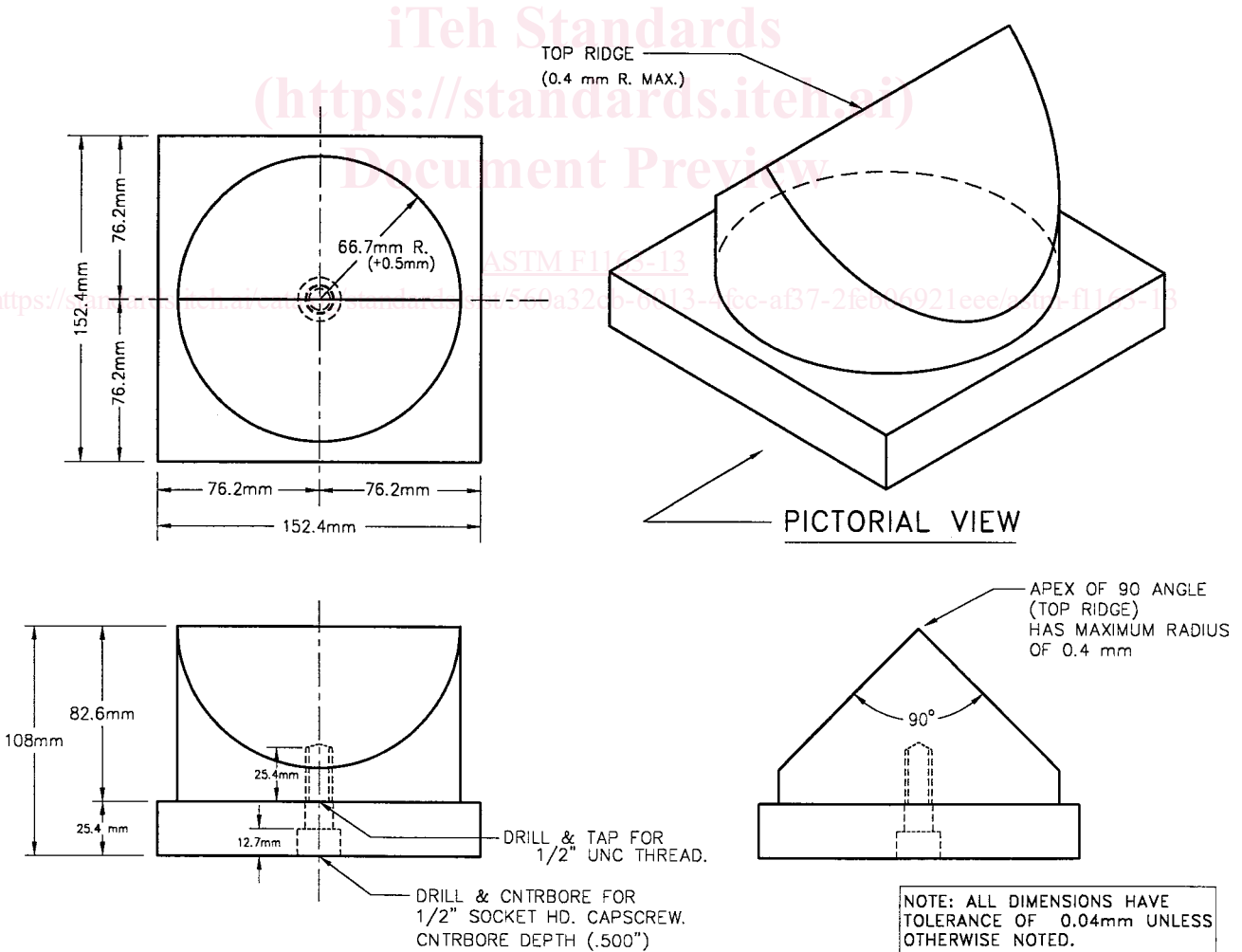

FIG. 1 Equestrian Hazard Anvil ("V" Anvil)