



Designation: C1574 – 04 (Reapproved 2013)

## Standard Guide for Determining Blown Density of Pneumatically Applied Loose-Fill Mineral Fiber Thermal Insulation<sup>1</sup>

This standard is issued under the fixed designation C1574; the number immediately following the designation indicates the year of original adoption or, in the case of revision, the year of last revision. A number in parentheses indicates the year of last reapproval. A superscript epsilon ( $\epsilon$ ) indicates an editorial change since the last revision or reapproval.

### 1. Scope

1.1 This guide describes two alternate procedures for determining blown density at a predetermined thickness or a range of thicknesses expected in field applications of mineral fiber loose-fill insulation.

1.2 This guide involves blowing a sample of loose-fill insulation into a test frame of known volume, measuring the weight of the insulation captured and calculating the blown density.

1.3 This guide is intended for pneumatically-applied loose-fill mineral fiber insulation designed for use in horizontal open attic spaces.

1.4 This guide is intended for product design and product auditing by manufacturers of loose-fill insulation. This guide is adaptable as a plant quality control procedure.

1.5 This guide does not predict the aged density of the mineral fiber loose-fill insulation.

1.6 *This standard does not purport to address all the safety concerns, if any, associated with its use. It is the responsibility of the user of this standard to establish appropriate safety and health practices and to determine the applicability of regulatory limitations prior to use.*

1.7 The values stated in inch-pound units are to be regarded as standard. The values given in parentheses are mathematical conversions to SI units that are provided for information only and are not considered standard.

### 2. Referenced Documents

2.1 *ASTM Standards:*<sup>2</sup>

[C168 Terminology Relating to Thermal Insulation](#)  
[C1374 Test Method for Determination of Installed Thick-](#)

[ness of Pneumatically Applied Loose-Fill Building Insulation](#)

### 3. Terminology

3.1 *Definitions*—Terminology [C168](#) is applicable to the terms used in this standard.

3.2 *Definitions of Terms Specific to This Standard:*

3.2.1 *Variable blown density*—change in density exhibited by loose-fill insulation as a function of thickness.

3.2.1.1 *Discussion*—Some loose-fill insulation materials exhibit an increase in blown density when thickness increases. Also, the original thickness may or may not decrease with time resulting in the same or somewhat higher densities. This thickness vs density relationship should be considered when developing coverage information for the bag label.

### 4. Significance and Use

4.1 Blown density is used to develop loose-fill coverage charts. Data for blown density vs thickness is used in the development of a variable blown density presentation for loose-fill insulation.

4.2 Thermal resistance (and conductivity) of loose-fill mineral fiber insulation depends on density and thickness. The resulting blown density data is useful in developing an expression for apparent thermal conductivity as a function of density. This will in turn aid the manufacturer in developing coverage information for packages of loose-fill insulation.

4.3 The blown density obtained in this method is for the thickness of the test only. The relationship of blown density with thickness can be determined by repeating the procedures outlined here using different thicknesses.

4.4 These procedures are not the same as the test method described in Test Method [C1374](#). Depending on the test conditions utilized, the blown density may, or may not, represent the installed density values obtained by using Test Method [C1374](#).

4.5 This guide can be used to develop appropriate blowing machine settings to achieve a target blown density at a predetermined thickness.

<sup>1</sup> This guide is under the jurisdiction of ASTM Committee [C16](#) on Thermal Insulation and is the direct responsibility of Subcommittee [C16.32](#) on Mechanical Properties.

Current edition approved March 1, 2013. Published March 2013. Originally approved in 2004. Last previous edition approved in 2008 as C1574–04(2008)<sup>ε1</sup>. DOI: 10.1520/C1574-04R13.

<sup>2</sup> For referenced ASTM standards, visit the ASTM website, www.astm.org, or contact ASTM Customer Service at service@astm.org. For *Annual Book of ASTM Standards* volume information, refer to the standard's Document Summary page on the ASTM website.

5. Summary of Guide

5.1 A standardized test chamber of fixed volume is used to collect the pneumatically-applied insulation.

5.2 There are two types of test chambers that are in common use:

5.2.1 Procedure A uses a moveable test box having a minimum volume of 20 cubic feet (0.56 m<sup>3</sup>). The blown material is weighed while still in the test box and the density is calculated.

5.2.2 Procedure B uses a fixed frame assembly in a test room or blowing shack to simulate an attic application. The blown material is removed from the test frame and weighed separately to calculate the density.

5.3 After the insulation is blown into the chamber, the weight of the insulation is determined.

5.4 From the volume of the sample and its weight, the blown density is determined.

6. Apparatus

6.1 *Blowing Machine*—a commercial pneumatic blowing machine, designed for handling mineral fiber loose-fill insulation materials, shall be used for blowing the insulation into the test chamber. This machine shall have throughput and handling characteristics representative of that used in field applications.

6.2 *Blowing Hose*—the machine shall utilize three (3) 50 ft (15 m) sections to make up 150 ft (46 m) of a minimum of 3

in. (76 mm) diameter flexible corrugated blowing hose. At least 100 ft. (30 m) of the hose shall have an elevation of between 10 and 20 ft (3 and 6 m) above the blowing machine to simulate a typical installation configuration. The hose shall have no more than eight 90-degree bends and no bends may be less than 4 ft (1.2 m) radius. After 50 h of usage, the last 50 ft (15 m) section at the discharge end shall be discarded. A new 50 ft (15 m) shall be attached directly to the blowing wool machine. The remaining 100 ft (30 m) shall then be attached to the end of the new hose. This creates a hose replacement rotation.

6.3 *Scales*—platform scales or load cells accurate to 1 %.

6.4 *Specimen Preparation Room*—an enclosed area where the test material is to be blown into the test chamber. This area is required to protect the blowing operation from wind or strong air currents. Room geometry should provide adequate clearance around the test chamber and large enough not to influence the blowing stream from the hose.

6.5 *Hose Nozzle Stand*—a hose stand on casters that holds the blowing hose at a fixed height of 36 to 48 in. (0.9 to 1.2 m) and is on a swivel that allows the operator to swing the hose horizontally back and forth while slowly moving backwards and forwards to fill the test chamber. A typical hose nozzle stand is shown in Fig. 1. Use of the hose stand is optional.

6.6 *Moveable Test Chamber (Procedure A)*—a wooden open container to collect the insulation. The chamber shall have a

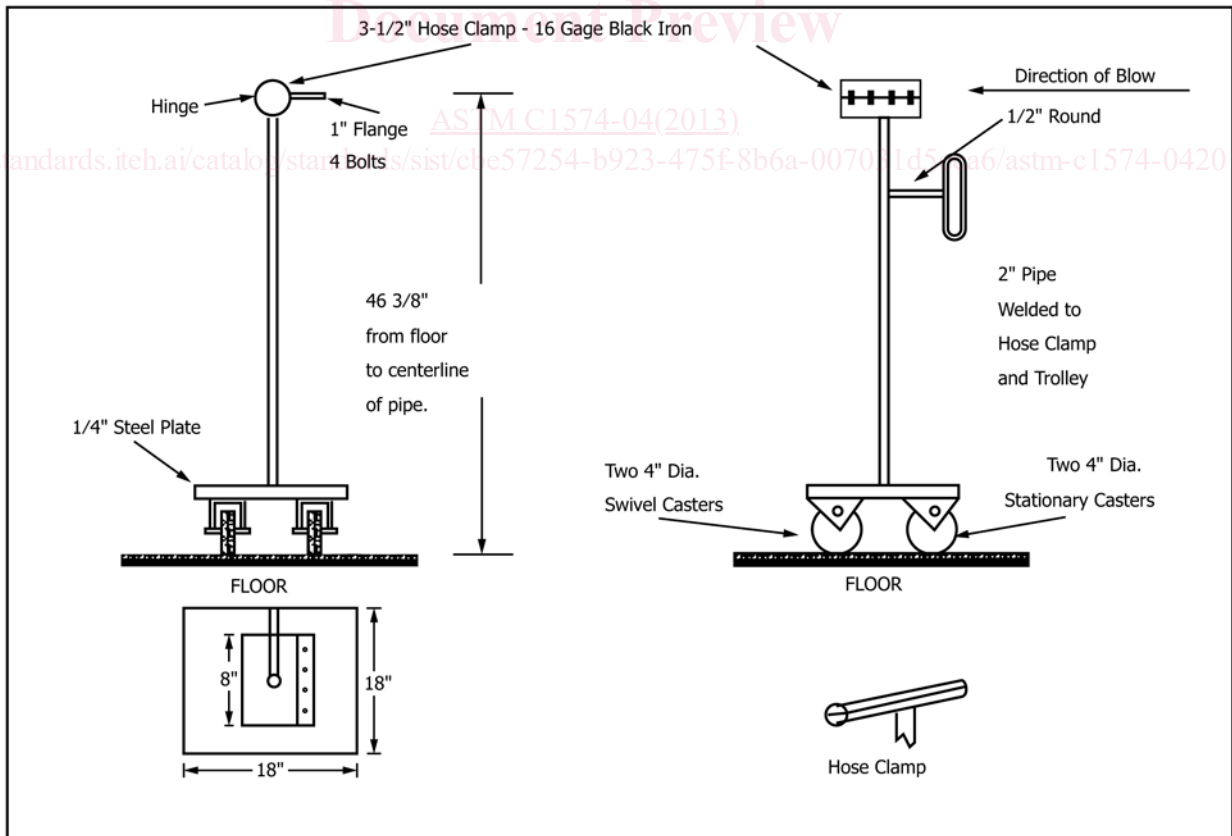

FIG. 1 Hose Nozzle Stand