**Plastics — Determination of
pourability**

Plastiques — Détermination de l'aptitude à l'écoulement

iTeh STANDARD PREVIEW
(standards.iteh.ai)

ISO 6186:2023

<https://standards.iteh.ai/catalog/standards/sist/0d28b2d4-079b-4507-b0c9-b1f3e505a50f/iso-6186-2023>



iTeh STANDARD PREVIEW (standards.iteh.ai)

ISO 6186:2023

<https://standards.iteh.ai/catalog/standards/sist/0d28b2d4-079b-4507-b0c9-b1f3e505a50f/iso-6186-2023>



COPYRIGHT PROTECTED DOCUMENT

© ISO 2023

All rights reserved. Unless otherwise specified, or required in the context of its implementation, no part of this publication may be reproduced or utilized otherwise in any form or by any means, electronic or mechanical, including photocopying, or posting on the internet or an intranet, without prior written permission. Permission can be requested from either ISO at the address below or ISO's member body in the country of the requester.

ISO copyright office
CP 401 • Ch. de Blandonnet 8
CH-1214 Vernier, Geneva
Phone: +41 22 749 01 11
Email: copyright@iso.org
Website: www.iso.org

Published in Switzerland

Contents

	Page
Foreword.....	iv
1 Scope.....	1
2 Normative references.....	1
3 Terms and definitions.....	1
4 Principle.....	1
5 Apparatus.....	1
6 Conditioning.....	3
7 Procedure.....	3
7.1 General.....	3
7.2 Method A.....	3
7.3 Method B.....	3
8 Expression of results.....	4
9 Test report.....	4

iTeh STANDARD PREVIEW (standards.iteh.ai)

ISO 6186:2023

<https://standards.iteh.ai/catalog/standards/sist/0d28b2d4-079b-4507-b0c9-b1f3e505a50f/iso-6186-2023>

Foreword

ISO (the International Organization for Standardization) is a worldwide federation of national standards bodies (ISO member bodies). The work of preparing International Standards is normally carried out through ISO technical committees. Each member body interested in a subject for which a technical committee has been established has the right to be represented on that committee. International organizations, governmental and non-governmental, in liaison with ISO, also take part in the work. ISO collaborates closely with the International Electrotechnical Commission (IEC) on all matters of electrotechnical standardization.

The procedures used to develop this document and those intended for its further maintenance are described in the ISO/IEC Directives, Part 1. In particular, the different approval criteria needed for the different types of ISO document should be noted. This document was drafted in accordance with the editorial rules of the ISO/IEC Directives, Part 2 (see www.iso.org/directives).

ISO draws attention to the possibility that the implementation of this document may involve the use of (a) patent(s). ISO takes no position concerning the evidence, validity or applicability of any claimed patent rights in respect thereof. As of the date of publication of this document, ISO had not received notice of (a) patent(s) which may be required to implement this document. However, implementers are cautioned that this may not represent the latest information, which may be obtained from the patent database available at www.iso.org/patents. ISO shall not be held responsible for identifying any or all such patent rights.

Any trade name used in this document is information given for the convenience of users and does not constitute an endorsement.

For an explanation of the voluntary nature of standards, the meaning of ISO specific terms and expressions related to conformity assessment, as well as information about ISO's adherence to the World Trade Organization (WTO) principles in the Technical Barriers to Trade (TBT), see www.iso.org/iso/foreword.html.

This document was prepared by Technical Committee ISO/TC 61, *Plastics*, Subcommittee SC 5, *Physical-chemical properties*, in collaboration with the European Committee for Standardization (CEN) Technical Committee CEN/TC 249, *Plastics*, in accordance with the Agreement on technical cooperation between ISO and CEN (Vienna Agreement).

This third edition cancels and replaces the second edition (ISO 6186:1998), which has been technically revised.

The main changes compared to the previous edition are as follows:

- [Clause 2](#) and [Clause 3](#) have been updated;
- [Clause 5](#) "Apparatus" has been technically revised;
- former Clause 9 "Precision" has been deleted and subsequent clause has been renumbered;
- former Clause 10 "Test report" has been renumbered as the new [Clause 9](#), and has been rearranged and revised.

Any feedback or questions on this document should be directed to the user's national standards body. A complete listing of these bodies can be found at www.iso.org/members.html.

Plastics — Determination of pourability

1 Scope

This document specifies two methods, A and B, for determining the pourability of plastics in powdered and granular form, by measuring the flow time through a funnel under specified conditions.

From method A, information concerning the processability can be derived, whilst method B is especially designed for process control during manufacture.

The methods specified are not necessarily applicable to all plastics in powdered and granular form.

2 Normative references

The following documents are referred to in the text in such a way that some or all of their content constitutes requirements of this document. For dated references, only the edition cited applies. For undated references, the latest edition of the referenced document (including any amendments) applies.

ISO 291, *Plastics — Standard atmospheres for conditioning and testing*

ISO 21920-2, *Geometrical product specifications (GPS) — Surface texture: Profile — Part 2: Terms, definitions and surface texture parameters*

3 Terms and definitions

For the purposes of this document, the following terms and definitions apply.

ISO and IEC maintain terminology databases for use in standardization at the following addresses:

- ISO Online browsing platform: available at <https://www.iso.org/obp>
- IEC Electropedia: available at <https://www.electropedia.org/>

3.1

flow time

time taken for a defined mass or volume of test material to flow through a funnel of specified dimensions under specified conditions

Note 1 to entry: It is expressed in seconds (s).

4 Principle

The time taken for a defined mass or volume of the test material to flow through a funnel of specified dimensions is measured under specified conditions.

5 Apparatus

5.1 Funnel, of the shape and dimensions shown in [Figure 1](#) and in [Table 1](#). Simple test funnels or test funnels with exchangeable nozzles may be used. The funnel shall be made of metal, for example stainless steel, and have a polished interior surface. The inside surface roughness of the funnel shall meet the requirements of roughness profile Ra 0,8 where Ra is specified in ISO 21920-2. The funnel shall be fitted with a device for closing the outlet (for example a metal plate). The funnel shall be earthed to discharge electrostatic charges.

Dimensions in millimetres

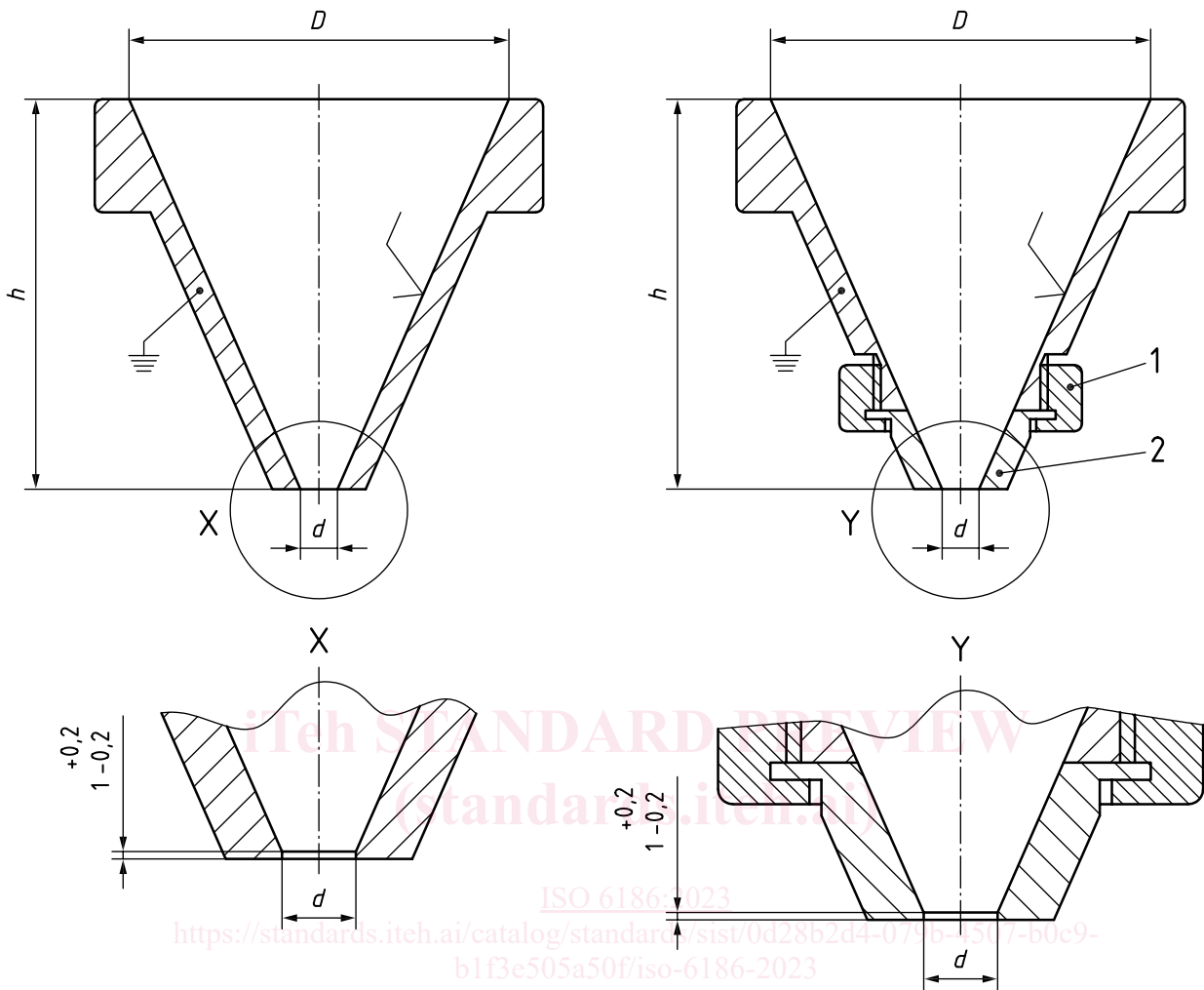

a) Simple test funnel

b) Test funnel with exchangeable nozzle

Key

D upper diameter

h height

d diameter of outlet

For values of d , h and D see [Table 1](#).



polished surface

1 union nut

2 nozzle

Figure 1 — Test funnel

Table 1 — Funnel dimensions

Dimensions in millimetres

Upper diameter, D	$110 \pm 0,5$	$110 \pm 0,5$	$110 \pm 0,5$
Diameter of outlet, d^a	$10,00 \pm 0,05$	$15,00 \pm 0,05$	$25,00 \pm 0,05$
Height of funnel, h	$140 \pm 0,5$	$133 \pm 0,5$	$119 \pm 0,5$

^a Deviating diameters of the outlet can be agreed between involved parties in case none of the values specified in [Table 1](#) is suitable. The use of deviating diameters of the outlet requires corresponding adaption of the funnel height to make sure that the funnel angle remains the same.

5.2 Funnel support, to hold the axis of the funnel vertically, for example a metal ring fixed to a vertical stand.

5.3 Stopwatch, accurate to 0,1 s, or an alternative means of measuring time with the same accuracy.

5.4 Balance, accurate to 0,1 g.

6 Conditioning

Unless otherwise specified, materials shall be tested as received under ambient atmospheric conditions. If the test atmosphere can affect the results, it may be specified that the sample be conditioned for 24 h at a temperature of $23\text{ °C} \pm 1\text{ °C}$ and $50\% \pm 5\%$ relative humidity, as specified in ISO 291, and tested in the same atmosphere.

7 Procedure

7.1 General

When using either method A or method B, start with $d = 10\text{ mm}$. If the sample does not flow through completely or does not flow at all, repeat the determination with $d = 15\text{ mm}$ or $d = 25\text{ mm}$ as necessary.

If the flow time is too short for a valid determination of pourability, a smaller outlet diameter agreed between involved parties may be used. In this case, corresponding adaption of the funnel height shall be done to make sure that the funnel angle remains the same.

7.2 Method A

7.2.1 Close the funnel outlet with the closing device. Pour $150\text{ g} \pm 1\text{ g}$ of the sample into the funnel, pouring it on to the inside wall in order to prevent compaction.

7.2.2 Remove the closing device rapidly, but without causing vibration, and simultaneously start the stopwatch. Stop the stopwatch when the funnel is empty, i.e. as soon as the funnel exit becomes visible when viewed from the top of the funnel. Read the flow time to the nearest 0,1 s.

7.2.3 Make three determinations under the same conditions, using a fresh test portion each time. After each determination, clean off any residue adhering to the inner surface of the funnel.

7.2.4 If the material does not flow because of electrostatic charges, repeat the test with the addition of a suitable amount of an antistatic agent agreed between the interested parties and record in the test report that antistatic agent was added.

7.3 Method B

7.3.1 Close the funnel outlet with the closing device. Pour sample into the funnel, pouring it on to the inside wall in order to prevent compaction, until the funnel is overfull and then level off the poured surface with a straight blade or spatula.

7.3.2 Remove the closing device rapidly, but without causing vibration, and simultaneously start the stopwatch. Stop the stopwatch when the funnel is empty, i.e. as soon as the funnel exit becomes visible when viewed from the top of the funnel. Read the flow time to the nearest 0,1 s.

7.3.3 Make three determinations under the same conditions, using a fresh test portion each time. After each determination, clean off any residue adhering to the inner surface of the funnel.

7.3.4 If the material does not flow because of electrostatic charges, repeat the test with the addition of a suitable amount of an antistatic agent agreed between the interested parties and record in the test report that antistatic agent was added.

8 Expression of results

8.1 Calculate the mean of the three determinations, expressing the flow time t , to the nearest whole second, in the way indicated by the following examples:

$$t_{A10} = 22 \text{ s}$$

or

$$t_{B15} = 22 \text{ s}$$

where

A = method A

B = method B

10 = 10 mm nozzle

15 = 15 mm nozzle

8.2 Indicate the manner in which the material flows, using the following terms:

- flows too fast;
- flows uniformly;
- flows intermittently;
- does not flow under the test conditions.

9 Test report

The test report shall include the following information:

- a) a reference to this document, including the year of publication;
- b) all details necessary for identification of the material tested;
- c) the moisture content, including the method of determination, if applicable;
- d) the type and amount of antistatic agent added, if applicable;
- e) the method used (A or B);
- f) the individual results and their mean value, the manner in which the material flowed and the diameter of the funnel nozzle outlet;
- g) any deviations from the procedure;
- h) any unusual features observed;
- i) the date of the test.

iTeh STANDARD PREVIEW
(standards.iteh.ai)

ISO 6186:2023

<https://standards.iteh.ai/catalog/standards/sist/0d28b2d4-079b-4507-b0c9-b1f3e505a50f/iso-6186-2023>