



FINAL DRAFT International Standard

ISO/FDIS 7692

Ferrotitanium — Determination of titanium content — Titrimetric method

Ferro-titane — Dosage du titane — Méthode titrimétrique

ISO/TC 132

Secretariat: **SAC**

Voting begins on:
2024-10-11

Voting terminates on:
2024-12-06

iteh Standards
(<https://standards.iteh.ai>)
Document Preview

[ISO/FDIS 7692](https://standards.iteh.ai/catalog/standards/iso/5a30cc21-a02a-46af-9e27-53276ce10c83/iso-fdis-7692)

<https://standards.iteh.ai/catalog/standards/iso/5a30cc21-a02a-46af-9e27-53276ce10c83/iso-fdis-7692>

RECIPIENTS OF THIS DRAFT ARE INVITED TO SUBMIT, WITH THEIR COMMENTS, NOTIFICATION OF ANY RELEVANT PATENT RIGHTS OF WHICH THEY ARE AWARE AND TO PROVIDE SUPPORTING DOCUMENTATION.

IN ADDITION TO THEIR EVALUATION AS BEING ACCEPTABLE FOR INDUSTRIAL, TECHNOLOGICAL, COMMERCIAL AND USER PURPOSES, DRAFT INTERNATIONAL STANDARDS MAY ON OCCASION HAVE TO BE CONSIDERED IN THE LIGHT OF THEIR POTENTIAL TO BECOME STANDARDS TO WHICH REFERENCE MAY BE MADE IN NATIONAL REGULATIONS.

iTeh Standards
(<https://standards.iteh.ai>)
Document Preview

[ISO/FDIS 7692](https://standards.iteh.ai/catalog/standards/iso/5a30cc21-a02a-46af-9e27-53276ce10c83/iso-fdis-7692)

<https://standards.iteh.ai/catalog/standards/iso/5a30cc21-a02a-46af-9e27-53276ce10c83/iso-fdis-7692>



COPYRIGHT PROTECTED DOCUMENT

© ISO 2024

All rights reserved. Unless otherwise specified, or required in the context of its implementation, no part of this publication may be reproduced or utilized otherwise in any form or by any means, electronic or mechanical, including photocopying, or posting on the internet or an intranet, without prior written permission. Permission can be requested from either ISO at the address below or ISO's member body in the country of the requester.

ISO copyright office
CP 401 • Ch. de Blandonnet 8
CH-1214 Vernier, Geneva
Phone: +41 22 749 01 11
Email: copyright@iso.org
Website: www.iso.org

Published in Switzerland

Contents

	Page
Foreword.....	iv
1 Scope	1
2 Normative references	1
3 Terms and definitions	1
4 Principle	1
5 Reagents	1
6 Apparatus	3
7 Sample	5
8 Procedure	5
8.1 Test portion.....	5
8.2 Blank test and check test.....	5
8.3 Determination.....	6
8.3.1 Decomposition of the test portion.....	6
8.3.2 Absence of interfering elements.....	6
8.3.3 Separation of interfering elements.....	6
8.3.4 Reduction.....	6
8.3.5 Titration.....	7
9 Expression of results	7
10 Precision	7
10.1 Expression of precision.....	7
10.2 Calculation of final results.....	8
11 Test report	8
Annex A (informative) Original data from the verification test	9
Annex B (informative) Graphical representation of the precision data	10
Annex C (informative) Flow chart for the acceptance procedure of test results	11
Bibliography	12

Foreword

ISO (the International Organization for Standardization) is a worldwide federation of national standards bodies (ISO member bodies). The work of preparing International Standards is normally carried out through ISO technical committees. Each member body interested in a subject for which a technical committee has been established has the right to be represented on that committee. International organizations, governmental and non-governmental, in liaison with ISO, also take part in the work. ISO collaborates closely with the International Electrotechnical Commission (IEC) on all matters of electrotechnical standardization.

The procedures used to develop this document and those intended for its further maintenance are described in the ISO/IEC Directives, Part 1. In particular, the different approval criteria needed for the different types of ISO document should be noted. This document was drafted in accordance with the editorial rules of the ISO/IEC Directives, Part 2 (see www.iso.org/directives).

ISO draws attention to the possibility that the implementation of this document may involve the use of (a) patent(s). ISO takes no position concerning the evidence, validity or applicability of any claimed patent rights in respect thereof. As of the date of publication of this document, ISO had not received notice of (a) patent(s) which may be required to implement this document. However, implementers are cautioned that this may not represent the latest information, which may be obtained from the patent database available at www.iso.org/patents. ISO shall not be held responsible for identifying any or all such patent rights.

Any trade name used in this document is information given for the convenience of users and does not constitute an endorsement.

For an explanation of the voluntary nature of standards, the meaning of ISO specific terms and expressions related to conformity assessment, as well as information about ISO's adherence to the World Trade Organization (WTO) principles in the Technical Barriers to Trade (TBT), see www.iso.org/iso/foreword.html.

This document was prepared by Technical Committee ISO/TC 132, *Ferrous alloys*.

This second edition cancels and replaces the first edition (ISO 7692:1983), which has been technically revised.

The main changes are as follows:

- in [5.5](#) (previously in 4.6), hydrofluoric acid has been replaced with fluoboric acid;
- in [5.13](#) (previously in 4.17), the concentration of titanium standard solution has been changed;
- in [5.13.1](#) (previously in 4.17.1), the amount of titanium(IV) dioxide has been reduced and the decomposition of titanium(IV) dioxide has been changed;
- in [5.13.2](#) (previously in 4.17.2), potassium hexafluorotitanate has been replaced with a titanium sponge and the preparation has been changed;
- in [Clause 6](#) (previously in Clause 5), PTE beakers has been replaced with conical flask;
- in [Clause 7](#) (previously in Clause 6), the mesh size of the sieve has been changed;
- the paragraph of the definition of test portion has been changed in [8.1](#) and the amount of test portion in [8.1](#) (previously 7.1) has been reduced from 1,0 g to 0,50 g;
- in 8.2.1, (previously in 7.4.1), the method using titanium sponge has been removed;
- in [8.3.1](#) (previously 7.5.1), the amount of acids has been reduced;
- in [8.3.4](#) (previously 7.5.3.2), the amount of the aluminium has been reduced from 4,0 g to 3,0 g ± 0,2 g;
- in [Clause 9](#) (previously in Clause 8), the expression of results has been changed;
- in [Clause 10](#), the precision has been added;
- in [Clause 11](#) (previously in Clause 9), the test report has been changed;

ISO/FDIS 7692:2024(en)

- [Annex A](#) has been added;
- [Annex B](#) has been added;
- [Annex C](#) has been added.

Any feedback or questions on this document should be directed to the user's national standards body. A complete listing of these bodies can be found at www.iso.org/members.html.

iTeh Standards (<https://standards.iteh.ai>) Document Preview

[ISO/FDIS 7692](#)

<https://standards.iteh.ai/catalog/standards/iso/5a30cc21-a02a-46af-9e27-53276ce10c83/iso-fdis-7692>

Ferrotitanium — Determination of titanium content — Titrimetric method

1 Scope

This document specifies a titrimetric method for the determination of the titanium content of ferrotitanium. The method is applicable to titanium contents of a mass fraction between 20,0 % and 80,0 % in ferrotitanium.

2 Normative references

The following documents are referred to in the text in such a way that some or all of their content constitutes requirements of this document. For dated references, only the edition cited applies. For undated references, the latest edition of the referenced document (including any amendments) applies.

ISO 385, *Laboratory glassware — Burettes*

ISO 648, *Laboratory glassware — Single-volume pipettes*

ISO 1042, *Laboratory glassware — One-mark volumetric flasks*

ISO 3696, *Water for analytical laboratory use — Specification and test methods*

ISO 3713, *Ferroalloys — Sampling and preparation of samples — General rules*

3 Terms and definitions

No terms and definitions are listed in this document.

ISO and IEC maintain terminology databases for use in standardization at the following addresses:

- ISO Online browsing platform: available at <https://www.iso.org/obp>
- IEC Electropedia: available at <https://www.electropedia.org/>

4 Principle

The test portion shall be dissolved with sulfuric, fluoboric, nitric and hydrochloric acids. And the interfering elements (chromium, vanadium, molybdenum and tin), if present, shall be separated by precipitation of titanium hydroxide in the presence of hydrogen peroxide. Then, the titanium shall be reduced to Ti^{3+} by aluminium metal in an atmosphere of carbon dioxide or nitrogen. Finally, the Ti^{3+} shall be titrated with standard volumetric iron(III) ammonium sulfate solution in the presence of thiocyanate as indicator.

5 Reagents

During the analysis, unless otherwise stated, use only reagents of recognized analytical grade and only grade 3 water specified in ISO 3696.

5.1 Aluminium, of minimum purity 99,5 %, in the form of foil 0,05 mm thick, and free from titanium.

5.2 Sodium hydrogen carbonate ($NaHCO_3$).

5.3 **Nitric acid**, with a ρ of 1,38 g/ml to 1,42 g/ml.

5.4 **Sulfuric acid**, $\rho = 1,84$ g/ml.

5.5 **Hydrochloric acid**, with a ρ of 1,16 g/ml to 1,19 g/ml.

5.6 **Fluoboric acid**, with a mass fraction of 40 % ($\rho = 1,39$ g/ml).

5.7 **Sulfuric acid**, $\rho = 1,84$ g/ml, diluted 1 + 1. Add carefully 1 volume of the sulfuric acid (5.4) to 1 volume of water. Cool while mixing.

5.8 **Sulfuric acid**, $\rho = 1,84$ g/ml, diluted 1 + 4. Add carefully 1 volume of the sulfuric acid (5.4) to 4 volume of water. Cool while mixing.

5.9 **Sodium hydroxide (NaOH) solution**, of 100 g/l.

5.10 **Sodium hydroxide (NaOH) solution**, of 20 g/l.

5.11 **Hydrogen peroxide (H₂O₂) solution**, of a volume fraction of 30 %.

5.12 **Iron(III) sulfate (Fe₂(SO₄)₃) solution**, of 15 g/l.

5.13 **Titanium standard solution**, of 1,0 mg/ml, prepared by one of the following methods.

5.13.1 Preparation from titanium(IV) dioxide

Weigh 0,417 2 g \pm 0,000 1 g of titanium(IV) dioxide (spectrum pure), which has been previously calcined for 2 h at 800 °C. In a 250 ml dry conical flask, dissolve the titanium(IV) dioxide with 10 g of ammonium sulfate and 20 ml of the sulfuric acid (5.4). Heat the conical flask on a hot-plate until the white sulfuric fumes appear, then allow to cool. Transfer quantitatively to a 250 ml volumetric flask. after cooling, dilute to the mark with water and mix.

ISO/FDIS 7692

<https://standards.iteh.ai/catalog/standards/iso/5a30cc21-a02a-46af-9e27-53276ce10c83/iso-fdis-7692>

5.13.2 Preparation from titanium sponge (99,8 % minimum purity)

In a 250 ml polytetrafluoroethylene (PTFE) beaker, dissolve 0,250 0 g \pm 0,000 1 g of titanium sponge (99,8 % minimum purity) with 40 ml of the sulfuric acid (5.7) and 5 ml of the hydrofluoric acid. Cover the beaker with a PTFE cover. Oxidize while cold by adding 5 ml of the nitric acid (5.3) drop by drop. Heat the PTFE beaker on a hot-plate until the white sulfuric fumes appear, then allow to cool. Transfer quantitatively to a 250 ml volumetric flask, after cooling, dilute to the mark with water and mix.

5.13.3 Certified reference materials (CRMs)

Alternatively, commercially available standard solutions of known concentration can be used instead of standard solutions produced in the laboratory. Variations in concentration shall be taken into account when calculating the results.

5.14 Ammonium iron (III) sulfate (NH₄Fe(SO₄)₂·12H₂O) standard volumetric solution.

5.14.1 Preparation

Place 10,2 g of the ammonium iron (III) sulfate in a 400 ml beaker, dissolve with about 100 ml of water and 50 ml of sulfuric acid (5.8). Transfer quantitatively to a 1 000 ml volumetric flask, dilute with water to the mark and mix.

5.14.2 Standardization

Transfer 25,00 ml of the titanium standard solution (see 5.13) into a 500 ml conical flask. Add 80 ml of the hydrochloric acid (see 5.5) and 25 ml of water. Rinse the inner wall of the conical flask with water and dilute to about 150 ml with water.

Proceed with the reduction as specified in 8.3.4.

Carry out a blank test, omitting the titanium standard solution.

The mass concentration of the ammonium iron(III) sulfate solution, ρ_1 , is given by [Formula \(1\)](#):

$$\rho_1 = \frac{m_1}{V_1 - V_2} \quad (1)$$

where

- m_1 is the mass, in grams, of titanium present in the aliquot portion of the titanium standard solution (see 5.13);
- V_1 is the volume, in millilitres, of the ammonium iron(III) sulfate solution (see 5.14) used for titration of the titanium standard solution (see 5.13);
- V_2 is the volume, in millilitres, of the ammonium iron(III) sulfate solution (see 5.14) used for titration of the blank test solution.

5.15 Ammonium thiocyanate, solution, 100 g/l.

5.16 Nitrogen, practically oxygen-free (less than 10 ppm by volume), 99,998 % pure, or carbon dioxide of similar purity.

6 Apparatus

All volumetric glassware shall be of Class A in accordance with ISO 648 and ISO 1042. An ordinary laboratory apparatus and the following shall be used.

6.1 Conical flask, capacity 250 ml.

6.2 Beakers, capacity 600 ml.

6.3 Flask, conical or round with a flat-base, of capacity 500 ml.

6.4 Bunsen valve of Goeckel condenser/bulb

The Bunsen valve (see [Figure 1](#)) comprises a rubber bung (Key 1) through which two glasses (Keys 2 and 6) pass. Rubber tubes (Key 3) are fitted onto these tubes, the upper ends being closed by glass plugs (Key 5). The rubber tube (Key 3), which is fitted on the glass tube (Key 2), is slit (Key 4) for a length of 10 mm to 15 mm in the middle of its length by a razor blade. The tube (Key 6), which ends 5 cm above the level of the solution to be titrated, makes it possible to introduce nitrogen or carbon dioxide by substituting the tube through which the gas is delivered for the rubber tube (Key 3).

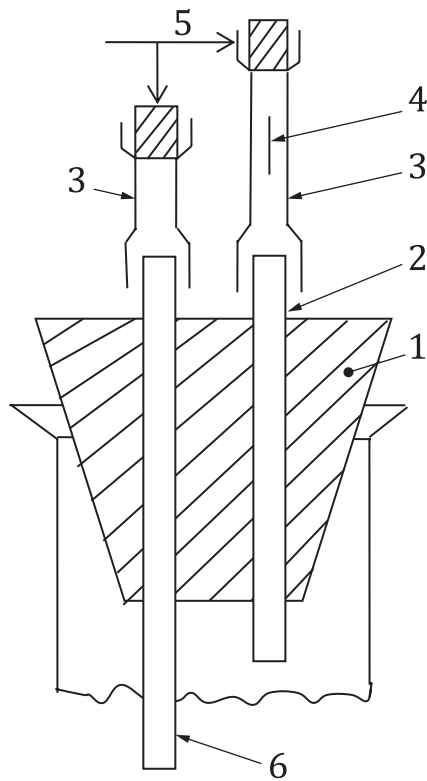

Key

- 1 rubber bung
- 2 glass tube
- 3 rubber tube
- 4 slit on glass tube
- 5 glass plugs
- 6 tube

iTeh Standards
(<https://standards.itih.ai>)
Document Preview

ISO/FDIS 7692

<https://standards.itih.ai/catalog/standards/iso-fdis-7692> **Figure 1 — Bunsen valve** <https://standards.itih.ai/catalog/standards/iso-fdis-7692>

6.5 Magnetic stirrer, with a PTFE covered stirring bar.