

FINAL  
DRAFT

INTERNATIONAL  
STANDARD

ISO/FDIS  
3549

ISO/TC 256

Secretariat: DIN

Voting begins on:  
**2023-10-24**

Voting terminates on:  
**2023-12-19**

---

---

## Zinc dust pigments for paints — Specifications and test methods

*Pigments à base de poussière de zinc pour peintures — Spécifications  
et méthodes d'essai*

iTeh Standards  
(<https://standards.iteh.ai>)  
Document Preview

ISO/FDIS 3549

<https://standards.iteh.ai/catalog/standards/sist/c42c945b-61c0-4935-ae15-863ff068dbf2/iso-fdis-3549>

**ISO/CEN PARALLEL PROCESSING**

RECIPIENTS OF THIS DRAFT ARE INVITED TO SUBMIT, WITH THEIR COMMENTS, NOTIFICATION OF ANY RELEVANT PATENT RIGHTS OF WHICH THEY ARE AWARE AND TO PROVIDE SUPPORTING DOCUMENTATION.

IN ADDITION TO THEIR EVALUATION AS BEING ACCEPTABLE FOR INDUSTRIAL, TECHNOLOGICAL, COMMERCIAL AND USER PURPOSES, DRAFT INTERNATIONAL STANDARDS MAY ON OCCASION HAVE TO BE CONSIDERED IN THE LIGHT OF THEIR POTENTIAL TO BECOME STANDARDS TO WHICH REFERENCE MAY BE MADE IN NATIONAL REGULATIONS.



Reference number  
ISO/FDIS 3549:2023(E)

© ISO 2023

iTeh Standards  
(<https://standards.iteh.ai>)  
Document Preview

ISO/FDIS 3549

<https://standards.iteh.ai/catalog/standards/sist/c42c945b-61c0-4935-ae15-863ff068dbf2/iso-fdis-3549>



**COPYRIGHT PROTECTED DOCUMENT**

© ISO 2023

All rights reserved. Unless otherwise specified, or required in the context of its implementation, no part of this publication may be reproduced or utilized otherwise in any form or by any means, electronic or mechanical, including photocopying, or posting on the internet or an intranet, without prior written permission. Permission can be requested from either ISO at the address below or ISO's member body in the country of the requester.

ISO copyright office  
CP 401 • Ch. de Blandonnet 8  
CH-1214 Vernier, Geneva  
Phone: +41 22 749 01 11  
Email: [copyright@iso.org](mailto:copyright@iso.org)  
Website: [www.iso.org](http://www.iso.org)

Published in Switzerland

# Contents

Page

Foreword.....	v
<b>1 Scope.....</b>	<b>1</b>
<b>2 Normative references.....</b>	<b>1</b>
<b>3 Terms and definitions.....</b>	<b>1</b>
<b>4 Required characteristics and tolerances.....</b>	<b>1</b>
<b>5 Sampling.....</b>	<b>3</b>
<b>6 Determination of residue on sieve.....</b>	<b>3</b>
6.1 Principle.....	3
6.2 Apparatus.....	3
6.3 Checking and cleaning the sieve.....	5
6.4 Procedure.....	5
6.5 Expression of results.....	5
<b>7 Determination of total zinc content.....</b>	<b>6</b>
7.1 Principle.....	6
7.2 Reagents.....	6
7.3 Procedure.....	7
7.3.1 Test portion.....	7
7.3.2 Determination.....	7
7.4 Expression of results.....	7
<b>8 Determination of metallic zinc content.....</b>	<b>8</b>
8.1 Principle.....	8
8.2 Reagents and materials.....	8
8.3 Procedure.....	9
8.3.1 General.....	9
8.3.2 Test portion.....	9
8.3.3 Determination.....	9
8.4 Expression of results.....	9
<b>9 Determination of lead, cadmium and iron content.....</b>	<b>10</b>
9.1 Principle.....	10
9.2 Reagents and materials.....	10
9.3 Apparatus.....	11
9.4 Procedure.....	11
9.4.1 Test portion.....	11
9.4.2 Preparation of test solutions.....	11
9.4.3 Determination.....	12
9.5 Expression of results.....	12
<b>10 Determination of arsenic content.....</b>	<b>13</b>
10.1 Principle.....	13
10.2 Reagents and materials.....	13
10.3 Apparatus.....	14
10.4 Procedure.....	15
10.4.1 Preparation of the calibration graph.....	15
10.4.2 Test portion.....	16
10.4.3 Preparation of the test solution.....	16
10.4.4 Determination.....	16
10.5 Expression of results.....	18
<b>11 Determination of chloride content.....</b>	<b>18</b>
11.1 Principle.....	18
11.2 Reagents and materials.....	18
11.3 Apparatus.....	18

11.4	Procedure.....	19
11.4.1	Preparation of the calibration graph.....	19
11.4.2	Determination.....	19
<b>12</b>	<b>Determination of matter insoluble in acid.....</b>	<b>19</b>
12.1	Reagents and materials.....	19
12.2	Apparatus.....	19
12.3	Procedure.....	19
12.3.1	Test portion.....	19
12.3.2	Determination.....	20
12.4	Expression of results.....	20
<b>13</b>	<b>Test report.....</b>	<b>20</b>
	<b>Bibliography.....</b>	<b>21</b>

**iTeh Standards**  
**(<https://standards.iteh.ai>)**  
**Document Preview**

[ISO/FDIS 3549](https://standards.iteh.ai/catalog/standards/sist/c42c945b-61c0-4935-ae15-863ff068dbf2/iso-fdis-3549)

<https://standards.iteh.ai/catalog/standards/sist/c42c945b-61c0-4935-ae15-863ff068dbf2/iso-fdis-3549>

## Foreword

ISO (the International Organization for Standardization) is a worldwide federation of national standards bodies (ISO member bodies). The work of preparing International Standards is normally carried out through ISO technical committees. Each member body interested in a subject for which a technical committee has been established has the right to be represented on that committee. International organizations, governmental and non-governmental, in liaison with ISO, also take part in the work. ISO collaborates closely with the International Electrotechnical Commission (IEC) on all matters of electrotechnical standardization.

The procedures used to develop this document and those intended for its further maintenance are described in the ISO/IEC Directives, Part 1. In particular, the different approval criteria needed for the different types of ISO document should be noted. This document was drafted in accordance with the editorial rules of the ISO/IEC Directives, Part 2 (see [www.iso.org/directives](http://www.iso.org/directives)).

ISO draws attention to the possibility that the implementation of this document may involve the use of (a) patent(s). ISO takes no position concerning the evidence, validity or applicability of any claimed patent rights in respect thereof. As of the date of publication of this document, ISO had not received notice of (a) patent(s) which may be required to implement this document. However, implementers are cautioned that this may not represent the latest information, which may be obtained from the patent database available at [www.iso.org/patents](http://www.iso.org/patents). ISO shall not be held responsible for identifying any or all such patent rights.

Any trade name used in this document is information given for the convenience of users and does not constitute an endorsement.

For an explanation of the voluntary nature of standards, the meaning of ISO specific terms and expressions related to conformity assessment, as well as information about ISO's adherence to the World Trade Organization (WTO) principles in the Technical Barriers to Trade (TBT), see [www.iso.org/iso/foreword.html](http://www.iso.org/iso/foreword.html).

This document was prepared by Technical Committee ISO/TC 256, *Pigments, dyestuffs and extenders*, in collaboration with the European Committee for Standardization (CEN) Technical Committee CEN/TC 298, *Pigments and extenders*, in accordance with the Agreement on technical cooperation between ISO and CEN (Vienna Agreement).

This third edition cancels and replaces the second edition (ISO 3549:1995), which has been technically revised.

The main changes are as follows:

- three types of zinc dust pigments (I, II and III) have been introduced with different requirements;
- inductively coupled plasma-optical emission spectroscopy (ICP-OES) has been added as an analytical technique used for elemental analysis;
- the nominal size of sieve aperture has been changed from 125  $\mu\text{m}$  – 90  $\mu\text{m}$  – 45  $\mu\text{m}$  to 125  $\mu\text{m}$  – 75  $\mu\text{m}$  – 45  $\mu\text{m}$ ;
- CAS numbers have been added to the reagents;
- the normative references have been updated;
- a bibliography has been added.

Any feedback or questions on this document should be directed to the user's national standards body. A complete listing of these bodies can be found at [www.iso.org/members.html](http://www.iso.org/members.html).



# Zinc dust pigments for paints — Specifications and test methods

## 1 Scope

This document specifies the requirements and corresponding test methods for zinc dust pigments suitable for use in protective coatings.

## 2 Normative references

The following documents are referred to in the text in such a way that some or all of their content constitutes requirements of this document. For dated references, only the edition cited applies. For undated references, the latest edition of the referenced document (including any amendments) applies.

ISO 565, *Test sieves — Metal wire cloth, perforated metal plate and electroformed sheet — Nominal sizes of openings*

ISO 3696, *Water for analytical laboratory use — Specification and test methods*

ISO 15528, *Paints, varnishes and raw materials for paints and varnishes — Sampling*

## 3 Terms and definitions

For the purposes of this document, the following terms and definitions apply.

ISO and IEC maintain terminology databases for use in standardization at the following addresses:

— ISO Online browsing platform: available at <https://www.iso.org/obp>

— IEC Electropedia: available at <https://www.electropedia.org/>

### 3.1

#### **zinc dust pigment**

fine grey powder of essentially spheroidal particles, mainly consisting of metallic zinc

Note 1 to entry: Zinc dust pigments for paints can vary in their metallic zinc content, chemical purity, particle shape, particle size distribution, mean and maximum diameter, etc. These variations are all likely to have an influence on the zinc dust behaviour in paints with regard to parameters such as dispersibility, fineness of grind, reactivity, electrical conductivity and packing properties.

## 4 Required characteristics and tolerances

4.1 For zinc dust pigments conforming to this document, the essential requirements are specified in [Table 1](#) and [Table 2](#).

**Table 1 — Composition of zinc dust pigment**

Characteristic	Unit	Requirement			Test method
		Type I	Type II	Type III	
Total zinc content	% (mass fraction)	min. 98	min. 98	min. 99	See <a href="#">Clause 7</a>
Metallic zinc content	% (mass fraction)	min. 94	min. 94	min. 97	See <a href="#">Clause 8</a>
Lead (Pb) content	% (mass fraction)	max. 0,1	max. 0,01	max. 0,002	See <a href="#">Clause 9<sup>a</sup></a>
Cadmium (Cd) content	% (mass fraction)	max. 0,03	max. 0,01	max. 0,001	See <a href="#">Clause 9<sup>a</sup></a>
Iron (Fe) content	% (mass fraction)	max. 0,005	max. 0,005	max. 0,002	See <a href="#">Clause 9<sup>a</sup></a>
Arsenic (As) content	% (mass fraction)	max. 0,000 5	max. 0,000 5	max. 0,000 5	See <a href="#">Clause 10<sup>a</sup></a>
Chloride (Cl) content	% (mass fraction)	max. 0,005	max. 0,005	max. 0,005	See <a href="#">Clause 11</a>
Matter insoluble in acid	% (mass fraction)	max. 0,05	max. 0,05	max. 0,05	See <a href="#">Clause 12</a>

<sup>a</sup> Other suitable methods such as the induction coupled plasma (ICP-OES or ICP-MS) method may be agreed upon between the interested parties.

NOTE If the zinc oxide content is required, this can be calculated by multiplying the difference between the total zinc content and the metallic zinc content by 1,244 7.

**Table 2 — Residue on sieve**

Nominal size of sieve aperture	Residue on sieve	Test method
µm	% (mass fraction)	
125	max. 0,01	See <a href="#">Clause 6</a>
75	max 0,1	
45	max. 0,5	

**4.2** Requirements for other physical properties (surface area, particle size distribution, etc.) and the choice of reference pigment to which these properties refer shall be the subject of agreement between the interested parties. Particle size and/or particle size distribution data as D10<sup>1)</sup>, D50<sup>2)</sup>, shall be given with reference to the measurement method and test conditions.

**4.3** The reference pigment shall also conform to the requirements given in [Table 1](#) and [Table 2](#).

**4.4** Inductively coupled plasma–optical emission spectroscopy (ICP-OES) is an analytical technique used for elemental analysis. The ICP-OES instrument is used in atomic spectroscopy. During analysis, the sample is decomposed by intense heat into a cloud of hot gases containing free atoms and ions of the element(s) of interest. The high temperatures cause significant amounts of collisional excitation and ionization of the sample atoms. Once the atoms or ions are in their excited state, they can decay to lower states through thermal or radiative (emission) energy transitions. During ICP-OES analysis, the intensity of the light emitted at specific wavelengths is measured and used to determine the

1) Industry term meaning the value of the particle diameter below which 10 % of the particles fall in the cumulative particle size distribution.

2) Industry term meaning the value of the particle diameter below which 50 % of the particles fall in the cumulative particle size distribution. It is also known as the median diameter.



concentration of the element(s) of interest. In ICP-OES analysis the thermal excitation sources can populate a large number of different energy levels for several different elements at the same time. All of the excited atoms and ions can then emit their characteristic radiation at the same time. This results in the flexibility to choose from several different emissions concurrently and allows detection of multiple elements concurrently.

Sample preparation for ICP-OES analysis is very similar to the sample preparation for atomic absorption (AA; see [Clause 9](#) and [Clause 10](#)) with a variant. (0,500 0 ± 0,000 2) g of sample is dissolved in 100 ml 5 % (volume fraction) HNO<sub>3</sub> 68 % (mass fraction). For very resistant samples, an additional 10 % (volume fraction) HCl 37 % (mass fraction) may be used in combination with microwave digestion. The 5 g/l solutions are further diluted (1/200) with 5 % (volume fraction) HNO<sub>3</sub> while adding 50 µg/l of Sc, Y, Rh and Lu as internal standards. ICP measurement and standard preparation can be derived from ISO 22036.

## 5 Sampling

Take a representative sample of the product to be tested, in accordance with ISO 15528.

**WARNING — The sample shall not be dried before testing, and any portion of the sample not used shall not be returned to the sample container after having been manipulated.**

## 6 Determination of residue on sieve

### 6.1 Principle

A suitable test portion of the sample is passed through an air-jet sieve apparatus, having sieves with nominal mesh apertures of 45 µm, 75 µm and 125 µm. The residue on each of these sieves is determined.

### 6.2 Apparatus

**6.2.1 Sieves**, circular, with a sieving area of diameter 200 mm and with nominal mesh apertures of 45 µm, 75 µm and 125 µm, conforming to ISO 565. A transparent lid shall be provided to cover the sieve during use.

**6.2.2 Air-jet sieve apparatus** (see [Figure 1](#)), consisting of a cylindrical casing which contains a sieve (see [6.2.1](#)). The base of the casing has an outlet (to which an extractor fan is connected) and an air inlet to permit the injection of air.

The air inlet is connected to a jet rotating at 20 min<sup>-1</sup> to 25 min<sup>-1</sup> and consists of a slot-shaped nozzle located beneath and very close to the sieve (see [Figure 1](#)). When the jet rotates, it blows air continuously through the sieve, preventing the powder particles from settling. The air is extracted through the outlet, drawing the finer particles through the sieve. The flow of air is controlled by adjusting a slot at the outlet.

The vacuum obtained shall be 1 250 Pa or lower.

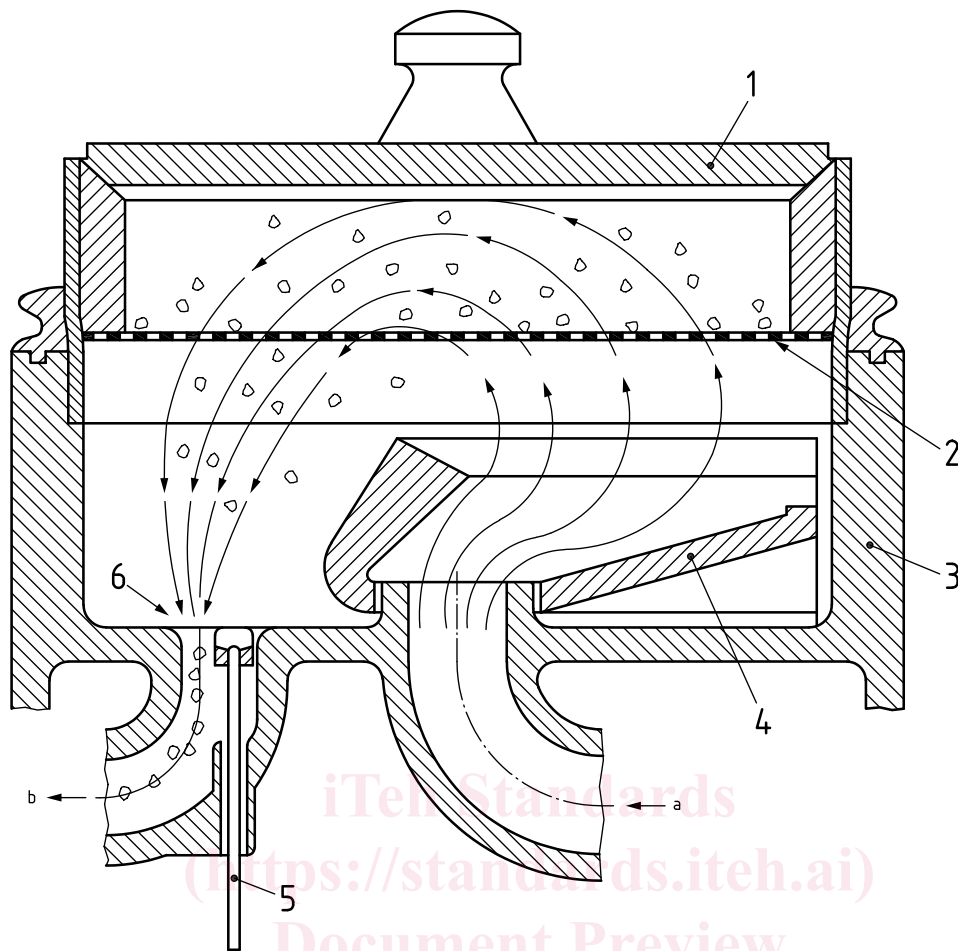

**Key**

- 1 transparent lid
- 2 sieve
- 3 casing
- 4 rotating jet
- 5 manometer
- 6 adjustable slot
- a Air inlet.
- b To extractor fan.

**Figure 1 — Air-jet sieve apparatus**

**6.2.3 Timer** (for example a stopwatch), recording to the nearest 1 s or better. It may be equipped with a switch for stopping the motor of the sieve apparatus (6.2.2).

**6.2.4 Analytical balance**, capable of weighing at least 50 g to the nearest 1 mg.

**6.2.5 Mallet**, of light construction, with a plastic head, suitable for tapping the apparatus to dislodge powder adhering to the lid and sieve.

**6.2.6 Clean brush**

**6.2.7 Stainless-steel boat**