

---

---

**Forestry machinery — Portable chain-  
saws — Minimum handle clearance  
and sizes**

*Machines forestières — Scies à chaîne portatives — Dimensions  
minimales des poignées et des espaces libres autour des poignées*

iTeh STANDARD PREVIEW  
(standards.iteh.ai)

ISO 7914:2023

<https://standards.iteh.ai/catalog/standards/sist/3157e136-e563-4d70-9ea2-6e6ee15e1feb/iso-7914-2023>



iTeh STANDARD PREVIEW  
(standards.iteh.ai)

ISO 7914:2023

<https://standards.iteh.ai/catalog/standards/sist/3157e136-e563-4d70-9ea2-6e6ee15e1feb/iso-7914-2023>



**COPYRIGHT PROTECTED DOCUMENT**

© ISO 2023

All rights reserved. Unless otherwise specified, or required in the context of its implementation, no part of this publication may be reproduced or utilized otherwise in any form or by any means, electronic or mechanical, including photocopying, or posting on the internet or an intranet, without prior written permission. Permission can be requested from either ISO at the address below or ISO's member body in the country of the requester.

ISO copyright office  
CP 401 • Ch. de Blandonnet 8  
CH-1214 Vernier, Geneva  
Phone: +41 22 749 01 11  
Email: [copyright@iso.org](mailto:copyright@iso.org)  
Website: [www.iso.org](http://www.iso.org)

Published in Switzerland

# Contents

Page

Foreword.....	iv
<b>1 Scope.....</b>	<b>1</b>
<b>2 Normative references.....</b>	<b>1</b>
<b>3 Terms and definitions.....</b>	<b>1</b>
<b>4 General requirements.....</b>	<b>1</b>
4.1 Front handle.....	1
4.2 Rear handle.....	4
<b>5 Clearance and dimensions.....</b>	<b>7</b>

iTeh STANDARD PREVIEW  
(standards.iteh.ai)

ISO 7914:2023

<https://standards.iteh.ai/catalog/standards/sist/3157e136-e563-4d70-9ea2-6e6ee15e1feb/iso-7914-2023>

## Foreword

ISO (the International Organization for Standardization) is a worldwide federation of national standards bodies (ISO member bodies). The work of preparing International Standards is normally carried out through ISO technical committees. Each member body interested in a subject for which a technical committee has been established has the right to be represented on that committee. International organizations, governmental and non-governmental, in liaison with ISO, also take part in the work. ISO collaborates closely with the International Electrotechnical Commission (IEC) on all matters of electrotechnical standardization.

The procedures used to develop this document and those intended for its further maintenance are described in the ISO/IEC Directives, Part 1. In particular, the different approval criteria needed for the different types of ISO document should be noted. This document was drafted in accordance with the editorial rules of the ISO/IEC Directives, Part 2 (see [www.iso.org/directives](http://www.iso.org/directives)).

ISO draws attention to the possibility that the implementation of this document may involve the use of (a) patent(s). ISO takes no position concerning the evidence, validity or applicability of any claimed patent rights in respect thereof. As of the date of publication of this document, ISO had not received notice of (a) patent(s) which may be required to implement this document. However, implementers are cautioned that this may not represent the latest information, which may be obtained from the patent database available at [www.iso.org/patents](http://www.iso.org/patents). ISO shall not be held responsible for identifying any or all such patent rights.

Any trade name used in this document is information given for the convenience of users and does not constitute an endorsement.

For an explanation of the voluntary nature of standards, the meaning of ISO specific terms and expressions related to conformity assessment, as well as information about ISO's adherence to the World Trade Organization (WTO) principles in the Technical Barriers to Trade (TBT), see [www.iso.org/iso/foreword.html](http://www.iso.org/iso/foreword.html).

This document was prepared by Technical Committee ISO/TC 23, *Tractors and machinery for agriculture and forestry*, Subcommittee SC 17, *Manually portable (hand-held) powered lawn and garden equipment and forest machinery*.

This fourth edition cancels and replaces the third edition (ISO 7914:2002), which has been technically revised. It also incorporates the Amendment ISO 7914:2002/AMD 1:2012.

The main changes are as follows:

- determination of reference points  $X_0$  and  $X_1$  has been clarified;
- determination of dimensions  $D$ ,  $E$ ,  $F_1$ ,  $F_2$ ,  $G_1$  and  $G_2$  has been clarified;
- measuring values on front handle, with spiked bumper provided, has been clarified.

Any feedback or questions on this document should be directed to the user's national standards body. A complete listing of these bodies can be found at [www.iso.org/members.html](http://www.iso.org/members.html).

# Forestry machinery — Portable chain-saws — Minimum handle clearance and sizes

## 1 Scope

This document specifies the minimum clearances and related dimensions for the front and rear handles of portable, hand-held chain-saws.

## 2 Normative references

The following documents are referred to in the text in such a way that some or all of their content constitutes requirements of this document. For dated references, only the edition cited applies. For undated references, the latest edition of the referenced document (including any amendments) applies.

ISO 6531, *Machinery for forestry — Portable chain-saws — Vocabulary*

ISO 6533, *Forestry machinery — Portable chain-saw front hand-guard — Dimensions and clearances*

## 3 Terms and definitions

For the purposes of this document, the terms and definitions given in ISO 6531 apply.

ISO and IEC maintain terminological databases for use in standardization at the following addresses:

— ISO Online browsing platform: available at <https://www.iso.org/obp>

— IEC Electropedia: available at <https://www.electropedia.org/>

## 4 General requirements

### 4.1 Front handle

The front handle shall be designed and positioned such that it provides an unobstructed surface throughout the grip area for a gloved hand operating the chain-saw. See [Figures 1](#) to [3](#).

The length of the grip area shall be limited by the reference points  $X_0$  and  $X_1$ , shown in [Figure 2](#). The reference point  $X_0$  shall be determined in accordance with ISO 6533.

Reference point  $X_1$  shall be determined by using a type A gauge (in accordance with ISO 6533) furthest down to the left side, as shown in [Figure 2](#).

The gauge shall be kept parallel with and directly to the side of the centreline of the front handle, and in contact with the handle. It shall be moved until it comes into contact with the housing of the machine or any obstruction.  $X_1$  is located where a plane on the lower circular area of the gauge intersects the handle.

When the machine design is such that a type A gauge cannot be inserted between the handle and the housing, the gauge shall be shortened, but by no more than needed.

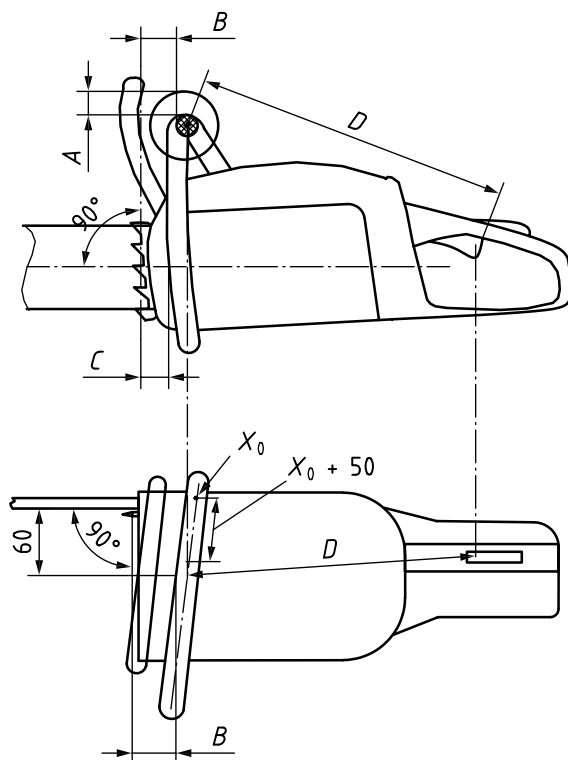

**Key**

$X_0$  reference point according to ISO 6533

NOTE For  $A, B, C, D$ , see [Table 1](#).

**Figure 1 — Clearance and distance between front and rear handles of chain-saw for forest service**

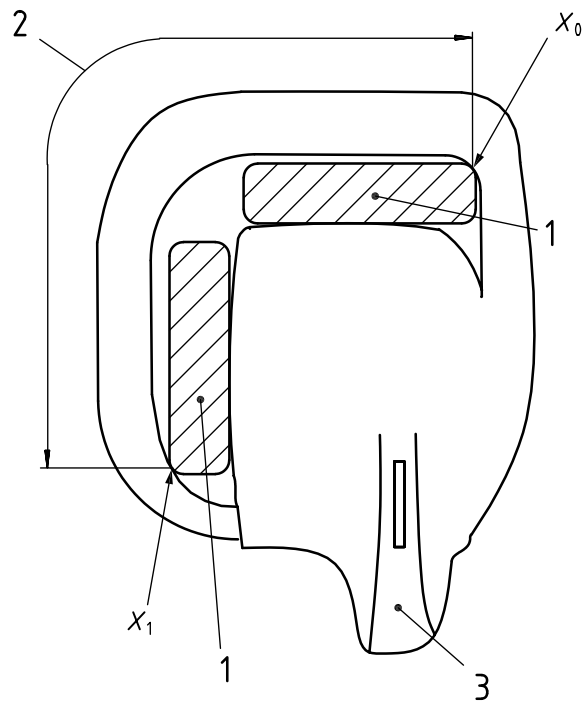

**Key**

- $X_0$  reference point according to ISO 6533
- $X_1$  reference point according to ISO 6533
- 1 gauge A (see ISO 6533)
- 2 grip area front handle
- 3 rear handle

ISO 7914:2023  
<https://standards.iteh.ai/catalog/standards/sist/3157e136-e563-4d70-9ea2-6e6ee15e1feb/iso-7914-2023>  
**Figure 2 — Front handle grip area**

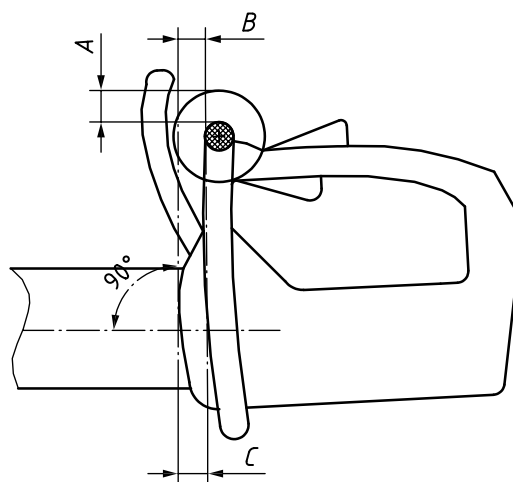

NOTE For A, B, C, see [Table 1](#).

**Figure 3 — Front handle clearances for chain-saws for tree service**

## 4.2 Rear handle

The rear handle shall provide enough space behind the throttle trigger for a gloved hand operating the chain-saw and shall not extend in front of the throttle trigger.

Dimensions in millimetres

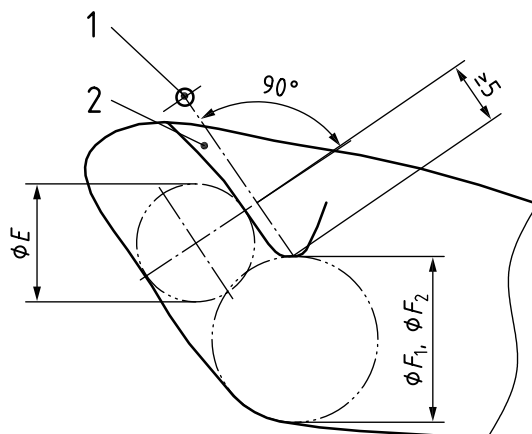

### Key

- 1 pivot point
- 2 throttle trigger

NOTE For  $F_1, F_2$  and  $E$ , see [Table 1](#).

**Figure 4 — Finger clearances at released throttle trigger**

ISO 7914:2023  
<https://standards.iteh.ai/catalog/standards/sist/3157e136-e563-4d70-9ea2-6e6ee15e1feb/iso-7914-2023>



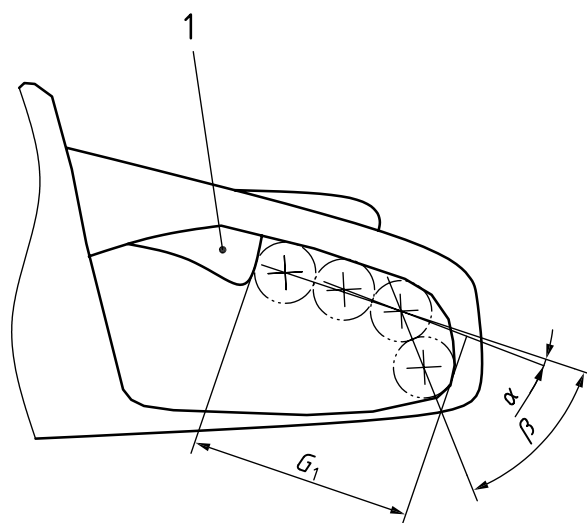

a) Chain-saw for forest service

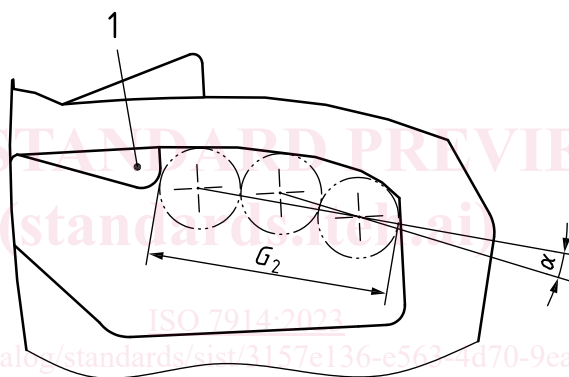

b) Chain-saw for tree service

**Key**

- 1 throttle trigger
- $\alpha$  =  $-15^\circ$  to  $+15^\circ$
- $\beta$  =  $-75^\circ$  to  $+75^\circ$

NOTE For  $G_1$  and  $G_2$ , see [Table 1](#).

**Figure 5 — Finger clearances behind released throttle trigger**

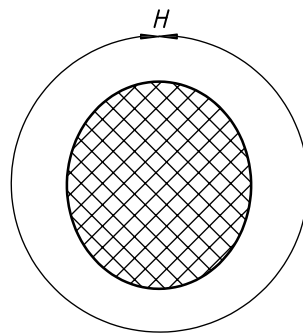

**a) Front handle**

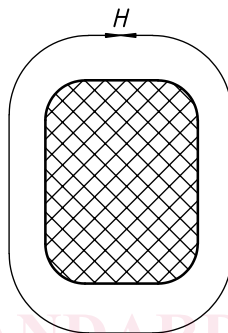

**b) Rear handle**

NOTE For  $H$ , see [Table 1](#).

iTeh STANDARD PREVIEW  
(standards.iteh.ai)

**Figure 6 — Perimeter of handle cross-section**

<https://standards.iteh.ai/catalog/standards/sist/3157e136-e563-4d70-9ea2-6e6ee15e1feb/iso-7914-2023>