

FINAL  
DRAFT

INTERNATIONAL  
STANDARD

ISO/FDIS  
6534

ISO/TC 23/SC 17

Secretariat: SIS

Voting begins on:  
2023-03-02

Voting terminates on:  
2023-04-27

---

---

## Forestry machinery — Portable chain-saw hand-guards — Mechanical strength

*Matériel forestier — Protections des mains des scies à chaîne  
portatives — Résistance mécanique*

iTeh STANDARD PREVIEW  
(standards.iteh.ai)

[ISO/FDIS 6534](https://standards.iteh.ai/catalog/standards/sist/34d5c30c-79dd-4741-a569-5efcec0f73ea/iso-fdis-6534)

<https://standards.iteh.ai/catalog/standards/sist/34d5c30c-79dd-4741-a569-5efcec0f73ea/iso-fdis-6534>

RECIPIENTS OF THIS DRAFT ARE INVITED TO SUBMIT, WITH THEIR COMMENTS, NOTIFICATION OF ANY RELEVANT PATENT RIGHTS OF WHICH THEY ARE AWARE AND TO PROVIDE SUPPORTING DOCUMENTATION.

IN ADDITION TO THEIR EVALUATION AS BEING ACCEPTABLE FOR INDUSTRIAL, TECHNOLOGICAL, COMMERCIAL AND USER PURPOSES, DRAFT INTERNATIONAL STANDARDS MAY ON OCCASION HAVE TO BE CONSIDERED IN THE LIGHT OF THEIR POTENTIAL TO BECOME STANDARDS TO WHICH REFERENCE MAY BE MADE IN NATIONAL REGULATIONS.



Reference number  
ISO/FDIS 6534:2023(E)

© ISO 2023

iTeh STANDARD PREVIEW  
(standards.iteh.ai)

ISO/FDIS 6534

<https://standards.iteh.ai/catalog/standards/sist/34d5c30c-79dd-4741-a569-5efcec0f73ea/iso-fdis-6534>



**COPYRIGHT PROTECTED DOCUMENT**

© ISO 2023

All rights reserved. Unless otherwise specified, or required in the context of its implementation, no part of this publication may be reproduced or utilized otherwise in any form or by any means, electronic or mechanical, including photocopying, or posting on the internet or an intranet, without prior written permission. Permission can be requested from either ISO at the address below or ISO's member body in the country of the requester.

ISO copyright office  
CP 401 • Ch. de Blandonnet 8  
CH-1214 Vernier, Geneva  
Phone: +41 22 749 01 11  
Email: [copyright@iso.org](mailto:copyright@iso.org)  
Website: [www.iso.org](http://www.iso.org)

Published in Switzerland

# Contents

	Page
Foreword.....	iv
<b>1 Scope.....</b>	<b>1</b>
<b>2 Normative references.....</b>	<b>1</b>
<b>3 Terms and definitions.....</b>	<b>1</b>
<b>4 Requirements.....</b>	<b>1</b>
<b>5 Test procedure.....</b>	<b>1</b>
5.1 General.....	1
5.2 Impact tests.....	2
5.2.1 General.....	2
5.2.2 Impact test for front hand-guard.....	2
5.2.3 Impact test for rear hand-guard.....	3
5.3 Durability test for front and rear hand-guards.....	4
5.3.1 General.....	4
5.3.2 Durability test for the front hand-guard.....	4
5.3.3 Durability test for the rear hand-guard.....	4
5.4 Fuel leakage for machines with a rear hand-guard with an integrated fuel tank.....	4

**iTeh STANDARD PREVIEW**  
(standards.iteh.ai)

[ISO/FDIS 6534](https://standards.iteh.ai/catalog/standards/sist/34d5c30c-79dd-4741-a569-5efcec0f73ea/iso-fdis-6534)

<https://standards.iteh.ai/catalog/standards/sist/34d5c30c-79dd-4741-a569-5efcec0f73ea/iso-fdis-6534>

## Foreword

ISO (the International Organization for Standardization) is a worldwide federation of national standards bodies (ISO member bodies). The work of preparing International Standards is normally carried out through ISO technical committees. Each member body interested in a subject for which a technical committee has been established has the right to be represented on that committee. International organizations, governmental and non-governmental, in liaison with ISO, also take part in the work. ISO collaborates closely with the International Electrotechnical Commission (IEC) on all matters of electrotechnical standardization.

The procedures used to develop this document and those intended for its further maintenance are described in the ISO/IEC Directives, Part 1. In particular, the different approval criteria needed for the different types of ISO documents should be noted. This document was drafted in accordance with the editorial rules of the ISO/IEC Directives, Part 2 (see [www.iso.org/directives](http://www.iso.org/directives)).

Attention is drawn to the possibility that some of the elements of this document may be the subject of patent rights. ISO shall not be held responsible for identifying any or all such patent rights. Details of any patent rights identified during the development of the document will be in the Introduction and/or on the ISO list of patent declarations received (see [www.iso.org/patents](http://www.iso.org/patents)).

Any trade name used in this document is information given for the convenience of users and does not constitute an endorsement.

For an explanation of the voluntary nature of standards, the meaning of ISO specific terms and expressions related to conformity assessment, as well as information about ISO's adherence to the World Trade Organization (WTO) principles in the Technical Barriers to Trade (TBT), see [www.iso.org/iso/foreword.html](http://www.iso.org/iso/foreword.html).

This document was prepared by Technical Committee ISO/TC 23, *Tractors and machinery for agriculture and forestry*, Subcommittee SC 17, *Manually portable (hand-held) powered lawn and garden equipment and forest machinery*.

This fourth edition cancels and replaces the third edition (ISO 6534:2007), which has been technically revised. It also incorporates the Amendment ISO 6534:2007/Amd. 1:2012.

The main changes are as follows:

- chain-saws for tree service have been included in the scope;
- requirement on breakage or cracks on hand-guards has been clarified;
- instructions on chain-saw conditioning before testing have been added;
- impact point on front and rear hand-guard has been clarified.

Any feedback or questions on this document should be directed to the user's national standards body. A complete listing of these bodies can be found at [www.iso.org/members.html](http://www.iso.org/members.html).

# Forestry machinery — Portable chain-saw hand-guards — Mechanical strength

## 1 Scope

This document specifies the mechanical strength requirements relating to the front and rear hand-guards of portable hand-held chain-saws for use primarily in forestry and for tree service. It also gives the corresponding test methods.

## 2 Normative references

The following documents are referred to in the text in such a way that some or all of their content constitutes requirements of this document. For dated references, only the edition cited applies. For undated references, the latest edition of the referenced document (including any amendments) applies.

ISO 6531:2017, *Machinery for forestry — Portable chain-saws — Vocabulary*

ISO 6533:2020, *Forestry machinery — Portable chain-saw front hand-guard — Dimensions and clearances*

## 3 Terms and definitions

For the purposes of this document, the terms and definitions given in ISO 6531 apply.

ISO and IEC maintain terminological databases for use in standardization at the following addresses:

- ISO Online browsing platform: available at <https://www.iso.org/obp>
- IEC Electropedia: available at <https://www.electropedia.org/>

## 4 Requirements

The front and rear hand-guards shall not break or crack when tested in accordance with [Clause 5](#). The front hand-guard shall not deflect far enough to allow the pendulum to swing past. Secondary impacts shall be avoided.

Before and after the test, the dimensions of the front hand-guard shall comply with the specifications of ISO 6533.

A reinforcing rib broken out at the impact point on the rear hand-guard is not regarded as break or crack, as long as the surface of the guard facing the operator's hand shows no breakage or cracks. If the fuel tank is integrated in the rear hand-guard design, any fuel leakage resulting from the test shall be considered as failure when inspected in accordance to [5.4](#).

## 5 Test procedure

### 5.1 General

The test shall be carried out with a new production chain-saw, rigidly held by the handles or the guide bar mount: It shall be mounted in an upright position for the front hand-guard test, and mounted upside down, rigidly held by the guide bar mount, for the rear hand-guard test (see [Figure 2](#) and [Figure 3](#)).

If the front hand-guard also serves as the activating device for the chain brake, it shall be in the activated position.

The impact on the guard shall be generated by a blow from a pendulum with a steel hammer in accordance with [Figure 1](#), and an arm with a length giving  $700 \text{ mm} \pm 5 \text{ mm}$  distance between the swivel point and the centre of the head. The arm shall be as light as possible. The pendulum system shall cause an impact corresponding to  $10 \text{ J} \pm 0,3 \text{ J}$  from a drop height,  $a$ , of 400 mm, and of  $5 \text{ J} \pm 0,2 \text{ J}$  from a drop height,  $a$ , of 200 mm.

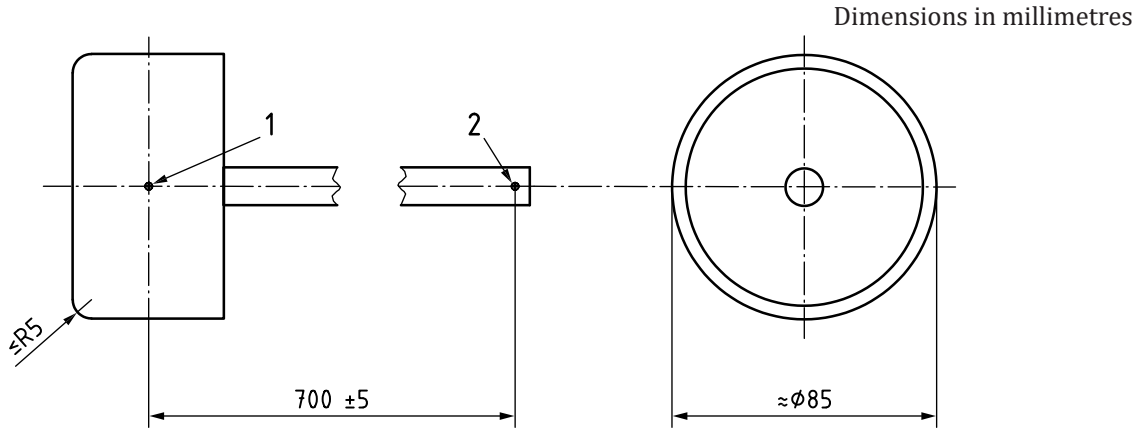

- Key**
- 1 centre of gravity
  - 2 swivel point

iTeh STANDARD PREVIEW  
**Figure 1 — Dimensions of hammer**  
 (standards.iteh.ai)

## 5.2 Impact tests

### 5.2.1 General

The tests in [5.2.2](#) and [5.2.3](#) shall be carried out once for each of the temperatures  $+40 \text{ °C} \pm 2 \text{ °C}$  and  $-25 \text{ °C} \pm 3 \text{ °C}$ . Before the test, condition the chain-saw at the test temperature for at least 6 h; within 60 s of taking the chain-saw out from the conditioning environment, carry out the test according to [5.2.2](#) and [5.2.3](#), respectively. If the chain-saw has to be removed from the conditioning environment to perform the tests, the tests shall be conducted within 60 s of its removal.

### 5.2.2 Impact test for front hand-guard

Raise the hammer and allow it to fall, so that it causes an impact corresponding to  $10 \text{ J} \pm 0,3 \text{ J}$ . The hammer shall strike the upper part of the guard at the midpoint of the effective guard width  $W_1$  as described in ISO 6533:2020, 7.1, along a line of action forming an angle of  $45^\circ \pm 5^\circ$  with the guide bar axis, in accordance with [Figure 2](#).

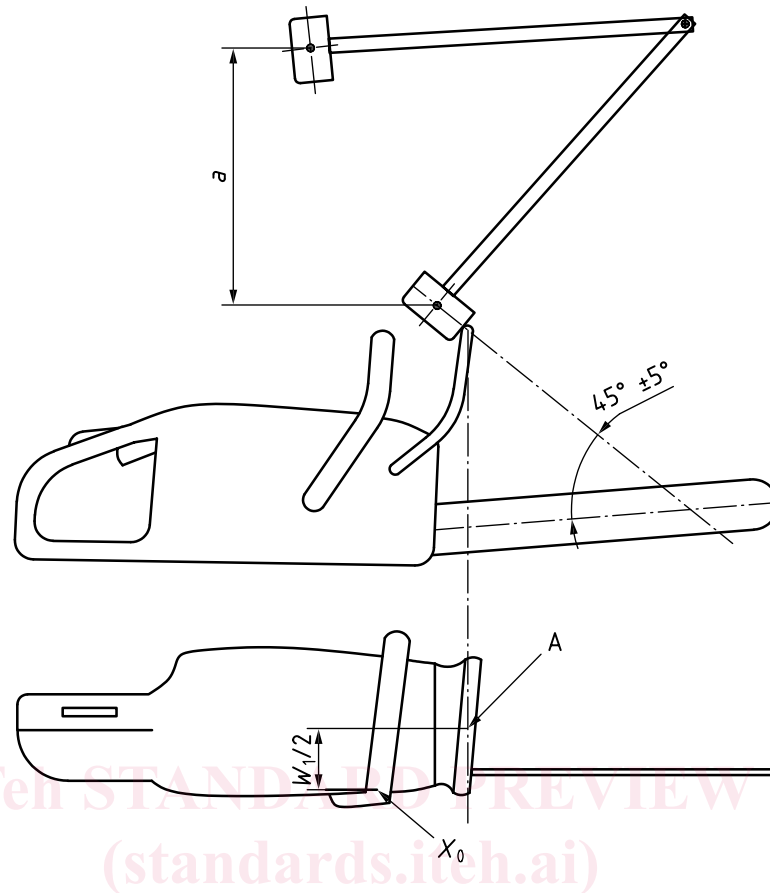
**Key**

a drop height

A impact point

 $X_0$  reference point according to ISO 6533 $W_1$  effective hand-guard width according to ISO 6533**Figure 2 — Impact test of front hand-guard****5.2.3 Impact test for rear hand-guard**

Raise the hammer and allow it to fall so that it causes an impact corresponding to  $10 \text{ J} \pm 0,3 \text{ J}$ . The hammer shall strike the hand-guard along a line of action forming an angle of  $45^\circ \pm 5^\circ$  with the guide bar axis, in accordance with [Figure 3](#).

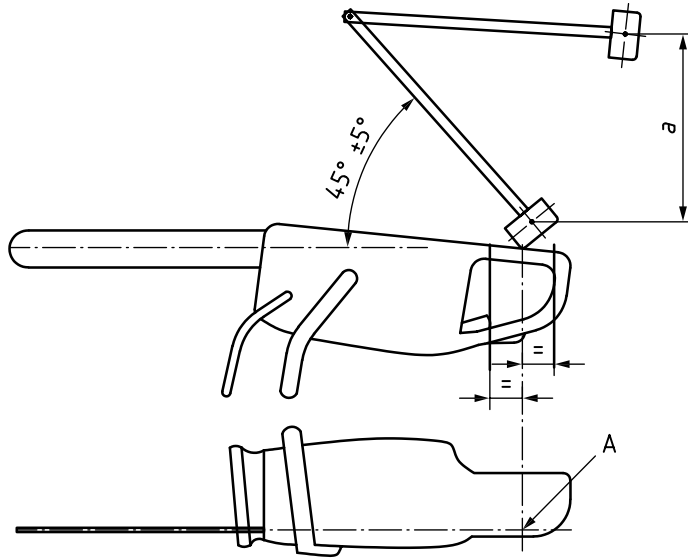

**Key**

- a drop height
- A impact point

**Figure 3 — Impact test of rear hand-guard**

The impact point shall be on the intersection of the centreline of the guide bar and the plane perpendicular to the guide bar plane, at an equal distance from the rear end of the throttle trigger and the inner far end of the handle [see A in [Figure 3](#)]. In cases where the point of intersection is less than 10 mm from the guard edge or outside the guard, the impact point shall be moved so that the distance from the guard edge is  $10\text{ mm} \pm 2,5\text{ mm}$ .

**5.3 Durability test for front and rear hand-guards**

**5.3.1 General**

This test shall be carried out at a temperature of  $+20\text{ °C} \pm 5\text{ °C}$ . Before the test, condition the chain-saw at the test temperature for at least 6 h.

**5.3.2 Durability test for the front hand-guard**

Raise the hammer and allow it to fall so that it causes an impact corresponding to  $5\text{ J} \pm 0,2\text{ J}$ . The hammer shall strike the guard at the same point as defined in [5.2.2](#).

Repeat this test to a total of 25 blows.

**5.3.3 Durability test for the rear hand-guard**

Raise the hammer and allow it to fall so that it causes an impact corresponding to  $5\text{ J} \pm 0,2\text{ J}$ . The hammer shall strike the guard at the same point as defined in [5.2.3](#).

Repeat this test to a total of 25 blows.

**5.4 Fuel leakage for machines with a rear hand-guard with an integrated fuel tank**

After conclusion of tests [5.2.3](#) and [5.3.3](#), inspect for visible leakage while holding the chain-saw for  $(30 \pm 2)\text{ s}$  in each of the positions b) to g) as specified in ISO 6531:2017, Figure A.1.





iTeh STANDARD PREVIEW  
(standards.iteh.ai)

ISO/FDIS 6534

<https://standards.iteh.ai/catalog/standards/sist/34d5c30c-79dd-4741-a569-5efcec0f73ea/iso-fdis-6534>