



Designation: ~~C12—09~~ **C12 – 13**

## Standard Practice for Installing Vitrified Clay Pipe Lines<sup>1</sup>

This standard is issued under the fixed designation C12; the number immediately following the designation indicates the year of original adoption or, in the case of revision, the year of last revision. A number in parentheses indicates the year of last reapproval. A superscript epsilon ( $\epsilon$ ) indicates an editorial change since the last revision or reapproval.

*This standard has been approved for use by agencies of the Department of Defense.*

### 1. Scope

1.1 This practice covers the proper methods of installing vitrified clay pipe lines in order to fully utilize the structural properties of such pipe.

1.2 The values stated in inch-pound units are to be regarded as standard. The values given in parentheses are mathematical conversions to SI units that are provided for information only and are not considered standard.

1.3 *This standard does not purport to address all of the safety concerns, if any, associated with its use. It is the responsibility of the user of this standard to establish appropriate safety and health practices and determine the applicability of regulatory limitations prior to use.*

### 2. Referenced Documents

2.1 *ASTM Standards:*<sup>2</sup>

[C301 Test Methods for Vitrified Clay Pipe](#)

[C403/C403M Test Method for Time of Setting of Concrete Mixtures by Penetration Resistance](#)

[C425 Specification for Compression Joints for Vitrified Clay Pipe and Fittings](#)

[C684 Test Method for Making, Accelerated Curing, and Testing Concrete Compression Test Specimens \(Withdrawn 2012\)](#)<sup>3</sup>

[C700 Specification for Vitrified Clay Pipe, Extra Strength, Standard Strength, and Perforated](#)

[C828 Test Method for Low-Pressure Air Test of Vitrified Clay Pipe Lines](#)

[C896 Terminology Relating to Clay Products](#)

[C1091 Test Method for Hydrostatic Infiltration Testing of Vitrified Clay Pipe Lines](#)

[D2487 Practice for Classification of Soils for Engineering Purposes \(Unified Soil Classification System\)](#)

[D6103 Test Method for Flow Consistency of Controlled Low Strength Material \(CLSM\)](#)

### 3. Terminology

3.1 *General*—Terminology [C896](#) can be used for clarification of terminology in this specification.

### DESIGN CONSIDERATIONS

### 4. Supporting Strength

4.1 The field supporting strength of vitrified clay pipe is materially affected by the methods of installation. The field supporting strength of a pipe is defined as its capacity to support dead and live loads under actual field conditions. It is dependent upon two factors: (1) the inherent strength of the pipe and (2) the bedding of the pipe.

4.2 The minimum bearing strength requirement in accordance with Specification [C700](#), as determined by the 3-edge-bearing test of Test Methods [C301](#), is a measure of the inherent strength of the pipe.

<sup>1</sup> This practice is under the jurisdiction of ASTM Committee [C04](#) on Vitrified Clay Pipe and is the direct responsibility of Subcommittee [C04.20](#) on Methods of Test and Specifications.

Current edition approved ~~Oct. 1, 2009~~ March 1, 2013. Published ~~October 2009~~ April 2013. Originally approved in 1915. Last previous edition approved in ~~2008~~ 2009 as ~~C12—08~~ C12 – 09. DOI: ~~10.1520/C0012-09~~ 10.1520/C0012-13.

<sup>2</sup> For referenced ASTM standards, visit the ASTM website, [www.astm.org](http://www.astm.org), or contact ASTM Customer Service at [service@astm.org](mailto:service@astm.org). For *Annual Book of ASTM Standards* volume information, refer to the standard's Document Summary page on the ASTM website.

<sup>3</sup> The last approved version of this historical standard is referenced on [www.astm.org](http://www.astm.org).

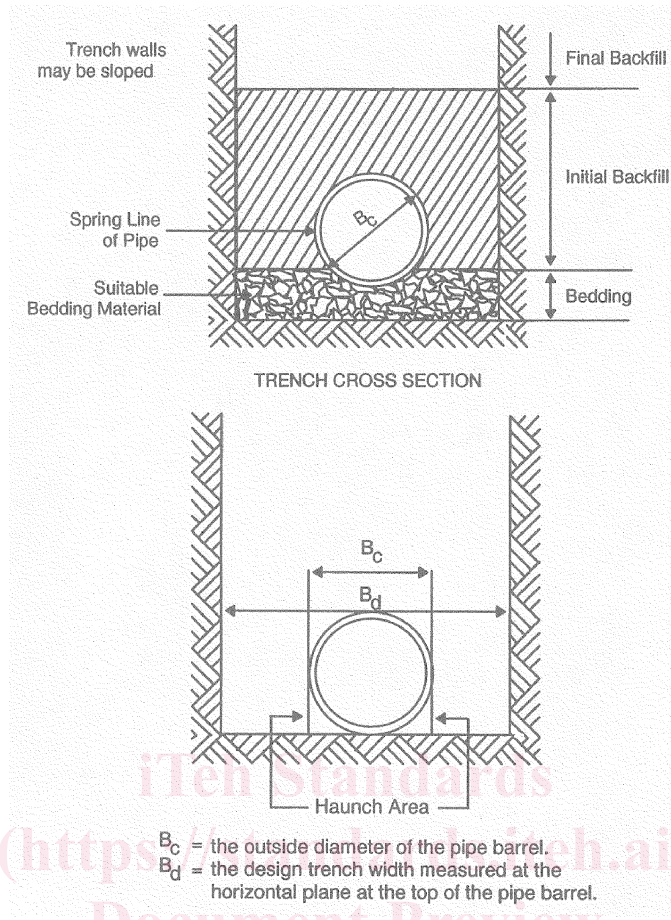

FIG. 1 Terminology

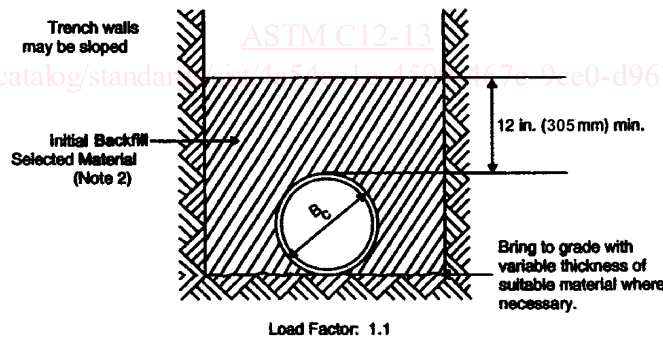

FIG. 2 Class D

4.3 The tests used to measure bearing strength determine relative pipe strengths but do not represent actual field conditions. Therefore, an adjustment called a load factor is introduced to convert minimum bearing strength to field supporting strength. The magnitude of the load factor depends on how the pipe is bedded. The relationship is:

$$\text{Field supporting strength} = \text{minimum bearing strength} \times \text{load factor}$$

4.4 A factor of safety greater than 1.0 and less than or equal to 1.5  $>1.0$  and  $\leq 1.5$  shall be applied to the field supporting strength to calculate a safe supporting strength. The relationship is:

$$\text{Safe supporting strength} = \frac{\text{Field supporting strength}}{\text{Factor of safety}}$$

## 5. External Loads

5.1 The external loads on installed vitrified clay pipe are of two general types: (1) dead loads and (2) live loads.

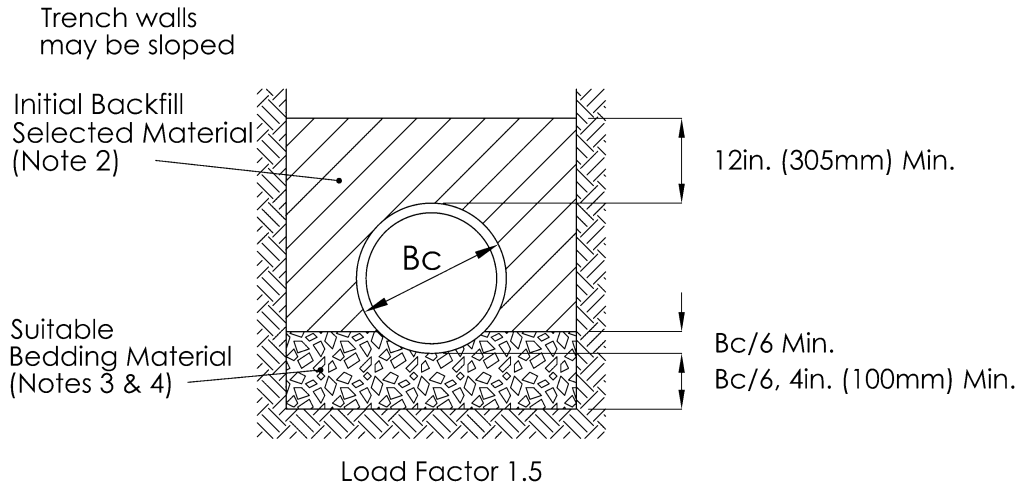

FIG. 3 Class C

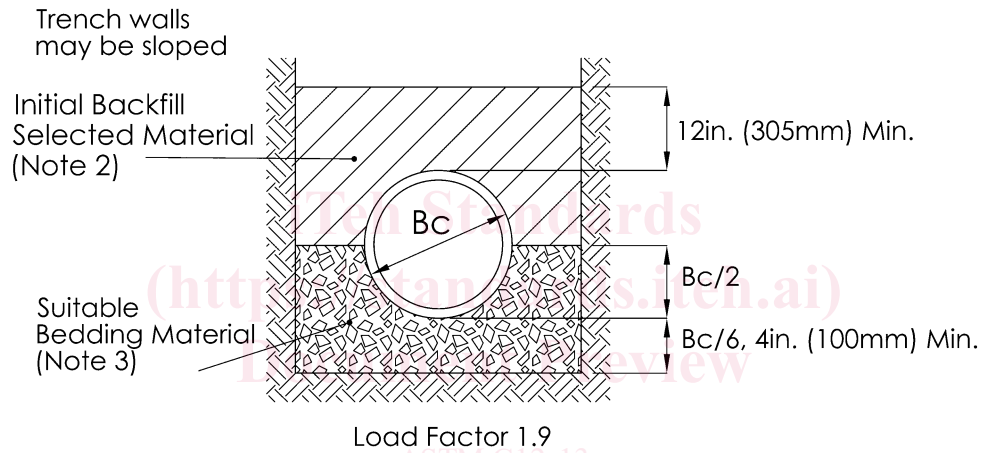

FIG. 4 Class B

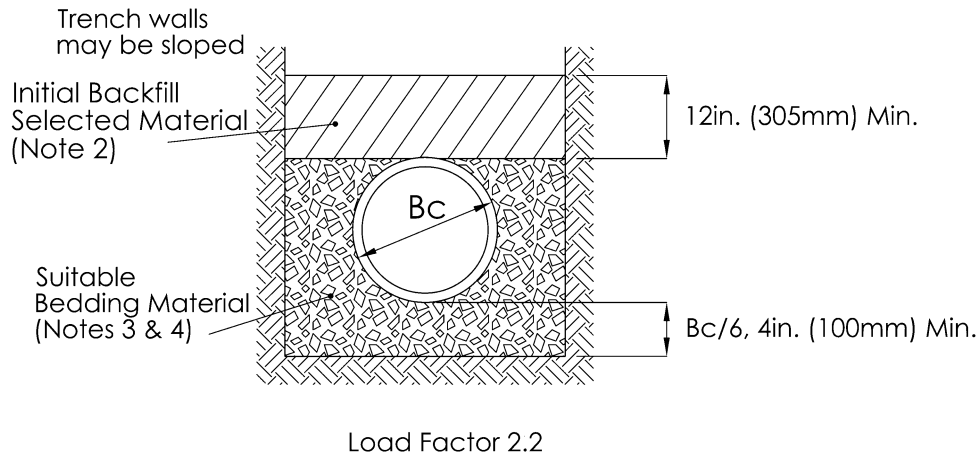
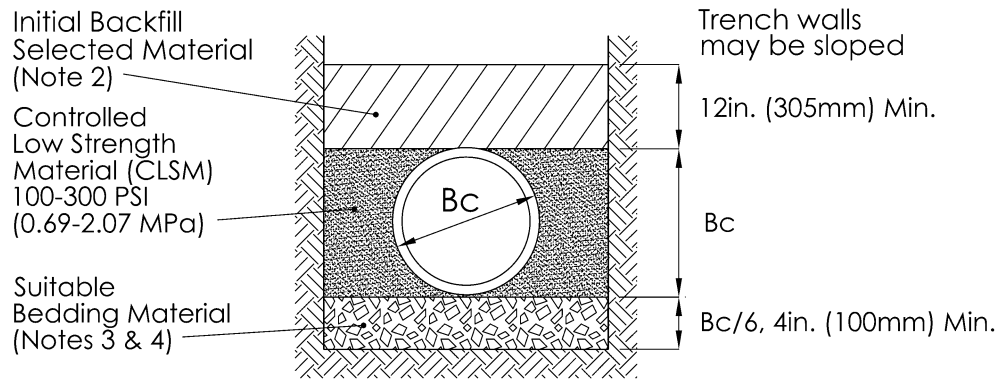

FIG. 5 Crushed Stone Encasement

5.2 For pipes installed in trenches at a given depth, the dead load increases as the trench width, measured at the top of the pipe, increases. Consequently, the trench width at the top of the pipe shall be kept as narrow as possible. Pipe failure may result if the design trench width is exceeded. If the trench width exceeds the design width, a higher class of bedding, stronger pipe, or both, must be investigated.

5.3 Live loads that act at the ground surface are partially transmitted to the pipe. Live loads may be produced by wheel loading, construction equipment or by compactive effort. Compaction of embedment and backfill materials, beside and above the sewer



Load Factor 2.8

NOTE 1—This type of construction requires the fill to extend from the pipe to the trench wall, not to extend above the top of the pipe or below the bottom of the pipe. Where native soils are expansive, further investigation may be necessary.

FIG. 6 Controlled Low Strength Material (CLSM)

pipe, produces a temporary live load on the pipe. The magnitude of the live load from compactive effort varies with soil type, degree of saturation, degree of compaction and depth of cover over the pipe. Care must be used in selection of compaction methods so that the combined dead load and live load does not exceed the field supporting strength of the pipe, or cause a change in its line or grade.

NOTE 1—For generally accepted criteria and methods for determining loads and supporting strengths, see *Gravity Sanitary Sewer Design and Construction, Water Pollution Control Federation Manual of Practice No. FD-5, American Society of Civil Engineers—Manuals and Report on Engineering Practice—No. 60*.<sup>4</sup>

## 6. Bedding and Encasement

6.1 Classes of bedding and encasements for pipe in trenches are defined herein. The load factors indicated are for conversion of minimum bearing strength to field supporting strength.

6.2 *Class D* (Fig. 2)—The pipe shall be placed on a firm and unyielding trench bottom with bell holes provided (Fig. 8). The initial backfill shall be of selected material (Note 2).

6.2.1 The load factor for Class D bedding is 1.1.

NOTE 2—Selected material is finely divided material free of debris, organic material, and large stones.

6.3 *Class C* (Fig. 3)—The pipe shall be bedded in clean coarse-grained gravels and sands as defined in Practice D2487, Table 1, (types SW, SP, GW, GP) (Note 4). Angular, non-consolidating bedding material not subject to migration may be specified (as in Note 3). The bedding shall have a minimum thickness beneath the pipe of 4 in. (100 mm) or one eighth of the outside diameter of the pipe, whichever is greater, and shall extend up the haunches of the pipe one sixth of the outside diameter of the pipe. The initial backfill shall be of selected material (Note 2).

6.3.1 The load factor for Class C bedding is 1.5.

NOTE 3—Suitable material is well-graded 3/4 to 1/4 in. (19 to 6.4 mm) crushed stone, having a minimum of one fractured face, or other angular, non-consolidating bedding material not subject to migration. Well-graded angular, non-consolidating bedding materials are more stable than rounded bedding materials of equal gradation. Material shall be shovel-sliced so the material fills and supports the haunch area and encases the pipe to the limits shown in the trench diagrams (Figs. 3-6).

NOTE 4—Sand is suitable as a bedding material in a total sand environment but may be unsuitable where high and rapidly changing water tables are present in the pipe zone. It may also be undesirable for bedding, or haunching in a trench cut by blasting or in trenches through clay type soil. Regardless of the trench condition or bedding class, the maximum load factor for sand bedding is 1.5.

6.4 *Class B* (Fig. 4)—The pipe shall be bedded in suitable material (Note 3). The bedding shall have a minimum thickness beneath the pipe of 4 in. (100 mm) or one eighth of the outside diameter of the pipe, whichever is greater, and shall extend up the haunches of the pipe to the springline. The initial backfill shall be of selected material (Note 2).

6.4.1 The load factor for Class B bedding is 1.9.

6.5 *Crushed Stone Encasement* (Fig. 5)—There are specific sites where crushed stone encasement may be desirable. The crushed stone shall extend to the specified trench width and shall have a minimum thickness beneath the pipe of 4 in. (100 mm) or one eighth of the outside diameter of the pipe, whichever is greater, and shall extend upward to a horizontal plane at the top of the pipe barrel (see Note 5). Encasement shall consist of well-graded 3/4 to 1/4 in. (19 to 6.4 mm) crushed stone or other

<sup>4</sup> Available from American Society of Civil Engineers (ASCE), 1801 Alexander Bell Dr., Reston, VA 20191, <http://www.asce.org>.