



Designation: **D1693—12 D1693 – 13**

Standard Test Method for Environmental Stress-Cracking of Ethylene Plastics¹

This standard is issued under the fixed designation D1693; the number immediately following the designation indicates the year of original adoption or, in the case of revision, the year of last revision. A number in parentheses indicates the year of last reappraisal. A superscript epsilon (ϵ) indicates an editorial change since the last revision or reappraisal.

This standard has been approved for use by agencies of the Department of Defense.

1. Scope*

1.1 This test method covers the determination of the susceptibility of ethylene plastics, as defined in Terminology **D883**, to environmental stress-cracking when subjected to the conditions herein specified. Under certain conditions of stress and in the presence of environments such as soaps, wetting agents, oils, or detergents, ethylene plastics may exhibit mechanical failure by cracking.

1.2 The values stated in SI units are to be regarded as standard.

1.3 *This standard does not purport to address all of the safety concerns, if any, associated with its use. It is the responsibility of the user of this standard to establish appropriate safety and health practices and determine the applicability of regulatory limitations prior to use.*

NOTE 1—There is no known ISO equivalent ~~for~~to this standard.

2. Referenced Documents

2.1 *ASTM Standards:*²

D618 Practice for Conditioning Plastics for Testing

D883 Terminology Relating to Plastics

D1204 Test Method for Linear Dimensional Changes of Nonrigid Thermoplastic Sheet or Film at Elevated Temperature

D1248 Specification for Polyethylene Plastics Extrusion Materials for Wire and Cable

D3350 Specification for Polyethylene Plastics Pipe and Fittings Materials

D4703 Practice for Compression Molding Thermoplastic Materials into Test Specimens, Plaques, or Sheets

D4976 Specification for Polyethylene Plastics Molding and Extrusion Materials

E691 Practice for Conducting an Interlaboratory Study to Determine the Precision of a Test Method

2.2 *ASTM Adjuncts:* <http://www.astm.org/catalog/standards/sist/5cc30b2a-76c3-4d22-898d-b35d92226079/astm-d1693-13>

Apparatus Drawings and Blueprints³

3. Terminology

3.1 *Definitions:*

3.1.1 *stress-crack, n*—an external or internal rupture in a plastic caused by tensile stresses less than its short-time mechanical strength.

¹ This test method is under the jurisdiction of ASTM Committee **D20** on Plastics and is the direct responsibility of Subcommittee **D20.15** on Thermoplastic Materials. Current edition approved April 1, 2012/April 1, 2013. Published May 2012/April 2013. Originally approved in 1959. Last previous edition approved in 2008/2012 as **D1693 – 08: D1693 - 12**. DOI: 10.1520/D1693-12; 10.1520/D1693-13.

² For referenced ASTM standards, visit the ASTM website, www.astm.org, or contact ASTM Customer Service at service@astm.org. For *Annual Book of ASTM Standards* volume information, refer to the standard's Document Summary page on the ASTM website.

³ Detail drawings of the apparatus are available from ASTM Headquarters. Request **ADJD169301, ADJD169302, ADJD169303, and ADJD169304**.

3.1.1.1 *Discussion*—

The development of such cracks is frequently accelerated by the environment to which the plastic is exposed. The stresses which cause cracking may be present internally or externally, or may be a combination of these stresses. The appearance of a network of fine cracks is called crazing.

*A Summary of Changes section appears at the end of this standard

3.1.2 *stress-crack failure, n*—for purposes of this test method, any crack visible to an observer with normal eyesight shall be interpreted as a failure of the entire specimen (1).⁴ Extension of the controlled imperfection shall not be construed as a failure. The appearance of more than one crack in a single specimen shall be construed as a single failure.

⁴ The boldface numbers in parentheses refer to the list of references at the end of this test method.

3.1.2.1 Discussion—

TABLE 1 Standard Test Conditions

Condition	Specimen Thickness		Notch Depth		Bath Temperature, °C
	mm ^A	in.	mm ^A	in.	
A ^B	min	3.00	0.120	0.50	50
	max	3.30	0.130	0.65	
B ^B	min	1.84	0.0725	0.30	50
	max	1.97	0.0775	0.40	
C ^C	min	1.84	0.0725	0.30	100 ^C
	max	1.97	0.0775	0.40	

^A Dimensional values are not exactly equivalent. However, for referee purposes the metric units shall apply.

^B For referee purposes, concentration of Igepal will be consistent with the appropriate material standard. If no concentration is given, then 10 % volume solution shall be used.

^C At a temperature of 100°C, a full-strength reagent, rather than an aqueous solution of a reagent, is generally used because solutions tend to change their compositions by water evaporation losses during the period of test.

iTeh Standards

Cracks generally develop at the controlled imperfection and run to the outer edge of the specimen approximately at right angles to it (2). The cracks need not extend completely through the specimen to constitute failure. Cracks sometimes develop under the polymer surface, manifesting themselves as depressions on the surface. The time when this occurs should be noted, and if the depression later develops into a crack, the time of dimpling should be considered as the failure time.

4. Summary of Test Method

4.1 Bent specimens of the plastic, each having a controlled imperfection on one surface, are exposed to the action of a surface-active agent. The proportion of the total number of specimens that crack in a given time is observed.

5. Significance and Use

5.1 This test method may be used for routine inspection purposes by subjecting a required number of specimens to the test conditions for a specified time and noting the number that fail. The cracking obtained with the test reagent is indicative of what may be expected from a wide variety of surface-active agents, soaps, and organic substances that are not absorbed appreciably by the polymer.

5.2 Environmental stress-cracking is a property that is highly dependent upon the nature and level of the stresses applied and on the thermal history of the specimen (1). Under the conditions of the test method, high local multiaxial stresses are developed through the introduction of a controlled imperfection (2, 3). Environmental stress-cracking has been found to occur most readily under such conditions.

NOTE 2—Different types of polyethylene plastics as defined in Specification D1248 are generally tested under different levels of strain and stress. When it is expressly desired to compare the types at equal levels of strain, the specimens for all types should be tested under Condition B, Table 1 (4).

5.3 Information from this test method is not intended to be used for direct application to engineering problems.

NOTE 3—Caution should be used in comparing and ranking various ethylene plastics into distinct and separate groups by this test method (see Section 13 and Note 12).

As thermal history is recognized as an important variable, test results by this test method employing laboratory molded samples cannot necessarily be expected to show agreement with test results from samples obtained by other means. The true performance potential of a given ethylene plastic may, however, best be determined with specimens obtained from commercially prepared items (5).

6. Apparatus

6.1 *Blanking Die*—A rectangular die or other means suitable for cutting specimens 38 ± 2.5 mm by 13 ± 0.8 mm (1.5 ± 0.1 in. by 0.50 ± 0.03 in.). These specimens must be cut with square edges. Beveled ends in particular are to be avoided.

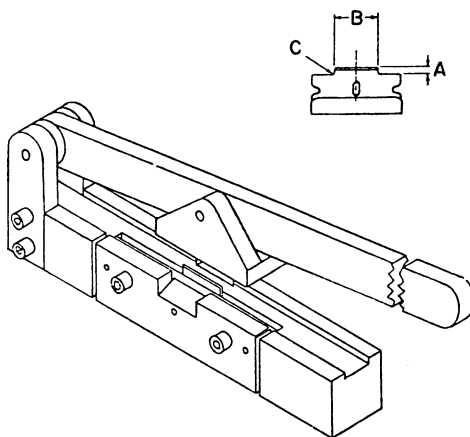

	mm	in.
A	3	1/8
B	18.9–19.2	0.745–0.755
C (radius)	1.5 max	1/16 max

FIG. 1 Nicking Jig

6.2 *Jig*—A jig for making a controlled imperfection in specimens of the dimensions shown in Table 1, parallel to the long edges of the specimen and centered on one of the broad faces. The jig as shown in Fig. 1 and capable of notching the specimens in accordance with 10.2 shall be used.

NOTE 4—It is recommended that the jig be permanently mounted to ensure notching consistency.

6.3 *Specimen Holders*—Lengths of hard or half-hard brass channel having the dimensions shown in (B) of Fig. 2 shall be used. The sides of the channel shall be parallel and the inside corners sharp and square. Any burrs present on the inside of the channel shall be removed. The inside width is critical (see Dimension F in Fig. 2).

6.4 *Test Tubes and Closures*—Hard glass tubes nominally 200 mm long with a preferred minimum inside diameter of 31.5 mm and a cork or rubber stopper. Alternatively, tubes with threaded ends and plastic caps are permissible.

NOTE 5—Some older test tubes have inside diameters of less than 31.5 mm. These are acceptable as long as there is adequate clearance to allow the filled specimen holder to be inserted into the tube without any interference.

NOTE 6—Hard glass (borosilicate) tubes and No. 15 corks have been found satisfactory.

6.5 *Aluminum Foil*—Approximately 0.08 to 0.13 mm (0.003 to 0.005 in.) thick, for wrapping.

6.6 *Constant-Temperature Bath*—A constant-temperature liquid bath maintained at $50.0 \pm 0.5^\circ\text{C}$ for Conditions A and B of Table 1 and $100.0 \pm 0.5^\circ\text{C}$ for Condition C of Table 1.

6.7 *Test Tube Rack*—A rack to hold test tubes immersed to reagent level.

6.8 *Bending Clamp*—As shown in Fig. 3.

6.9 *Transfer Tool*—As shown in Fig. 4.

7. Reagent

7.1 The preferred reagent is a nonylphenoxy poly(ethyleneoxy)ethanol.⁵

NOTE 7—There are environmental concerns regarding the disposal of Nonylphenoxy poly(ethyleneoxy) ethanol (CAS 68412-54-4), for example, Igepal CO-630. Users are advised to consult their supplier or local environmental office and follow the guidelines provided for the proper disposal of this chemical.

NOTE 8—The reagent should be stored in closed metal or glass containers because it is somewhat hygroscopic.

NOTE 9—The manufacturer has stated that this aggressive agent undergoes no known degradation when used as follows: A10 % volume solution in water at 50°C for 1000 h of testing.

NOTE 10—The appearance of carbonyl bands in an Igepal Fourier transform infrared (FT-IR) scan is an indication of degradation.

7.2 Other surface-active agents, soaps, or any liquid organic substance that is not absorbed appreciably by the polymer can also be used.

⁵ For referee purposes Igepal CO-630 should be obtained from Rhone-Poulenc, Prospect Plains, Cranbury, NJ 08512.

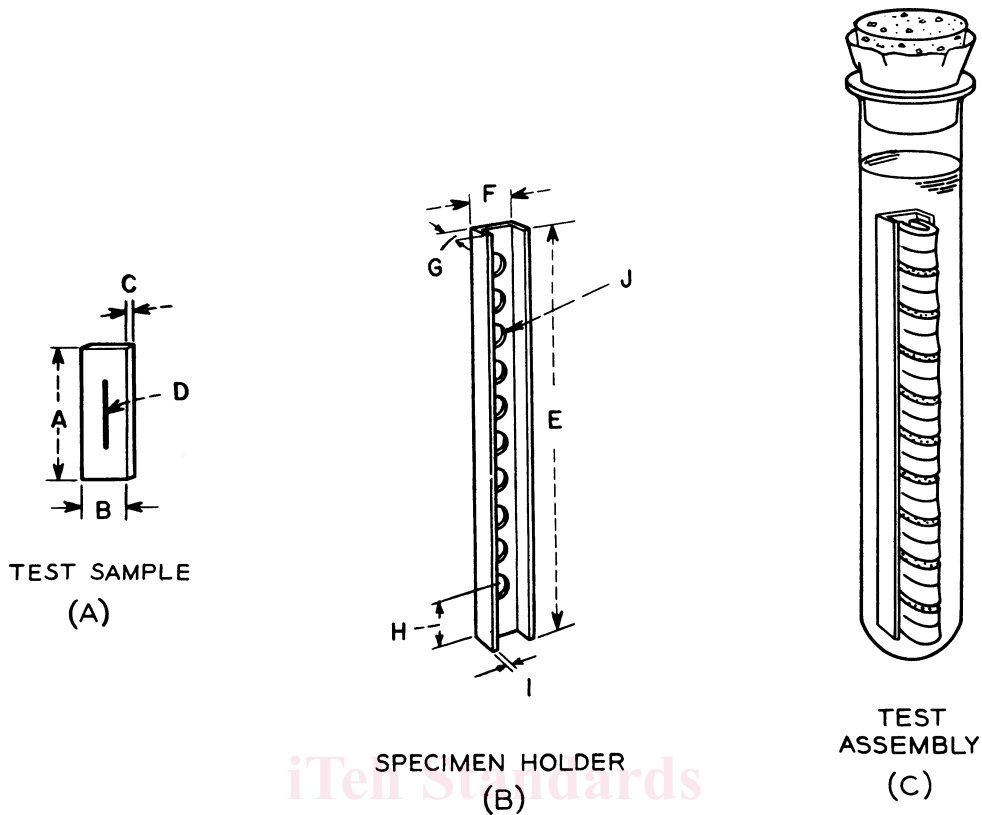

ASTM Standards
 (https://standards.iteh.ai)
 Document Preview

	Dimensions	
	mm	in.
A	38 ± 2.5	1.5 ± 0.1
B	13 ± 0.8	0.5 ± 0.03
C	see Table 1	
D	see Table 1	
E	165	6 ½
F		
(outside)	16	5/8
(inside)	11.75 ± 0.05	0.463 ± 0.002
G	10	3/8
H	15	37/64
I	2	0.081 (12 B & S)
J	ten 5-mm holes 15-mm centers	ten 3/16-in. holes, 19/32-in. centers

FIG. 2 Test Equipment

8. Test Specimen

8.1 Unless otherwise specified, the test specimens shall be molded in accordance with Procedure C of Annex A1 of Practice D4703.

NOTE 11—Use no liquid release agents, waxes, polishes, and so forth, when molding. However, inert materials such as polyester film, unplasticized cellophane, polytetrafluoroethylene, and aluminum foil have been found satisfactory.

8.2 Sheets may be examined for internal stresses by taking specimens from random locations in the sheet and placing them in a Petri dish containing 3 mm (1/8 in.) of talc and setting the dish in an air oven at 130°C for Types I and II polyethylene plastic and at 150°C for Types III and IV polyethylene plastic for 30 minutes. If shrinkage of the specimens is less than 10 % in the lengthwise direction, the molded sheet can be considered satisfactory (see also Test Method D1204).

8.3 Cut specimens from smooth sheet pressed from granules or mill-massed material to the dimensions given in Fig. 2 (A). Use a die or other device that produces specimens with clean-cut, square, unbeveled edges. The specimens should be cut within 24 h after the sheets are prepared.

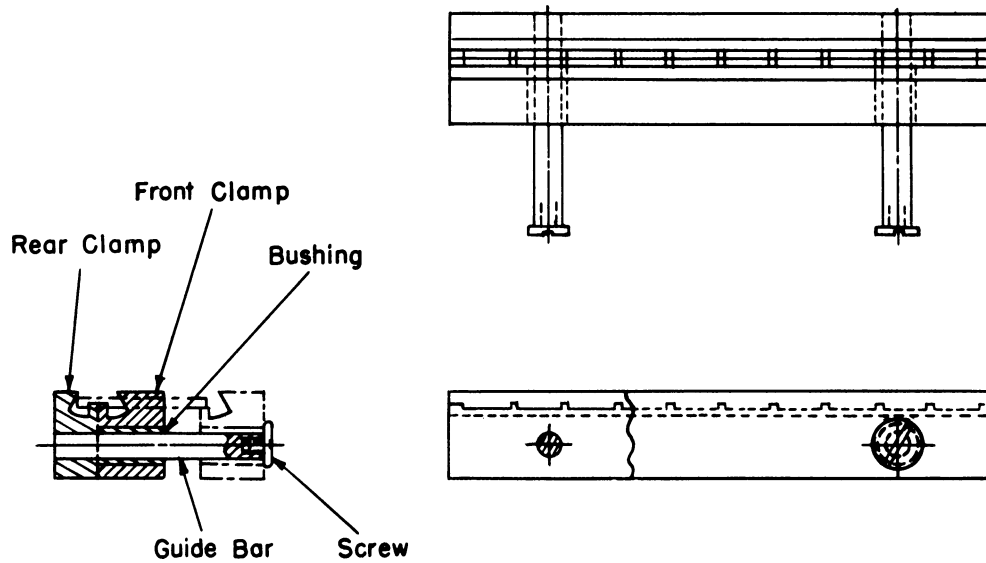
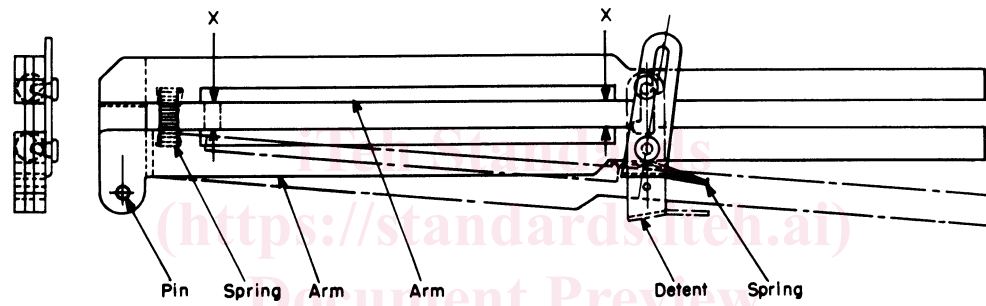

FIG. 3 Bending Clamp Assembly



NOTE 1—X = 10.5 ± 0.5 mm (0.41 ± 0.02 in.)

FIG. 4 Transfer Tool Assembly

ASTM D1693-13

<https://standards.iteh.ai/catalog/standards/sist/5cc30b2a-76c3-4d22-898d-b35d92226079/astm-d1693-13>

9. Conditioning

9.1 Unless otherwise specified, the test specimens should be conditioned in accordance with Procedure A of Practice D618. Do not bend the test specimens, nick, or treat them with the reagent until immediately prior to the test. Testing should be started a minimum of 40 h and a maximum of 96 h after conditioning the specimens has begun.

10. Procedure

10.1 Select the condition desired from Table 1.

NOTE 12—Generally, polyethylene plastics with densities between 0.910 and 0.925 are tested under Condition A. Polyethylenes with densities >0.925 are tested under Condition B. Condition C may be used to accelerate testing for materials with extremely high ESCR values. The user of this test method should refer to the material specifications such as D1248, D3350, or D4976 for specific test conditions.

10.2 Give each conditioned specimen a controlled imperfection (notch) on one surface as shown in (A) of Fig. 2. Use a sharp blade, mounted in the jig shown in Fig. 1, for making this imperfection. A depth micrometer may be used for setting the blade in the jig so that the notch depth is controlled as specified in Table 1. The difference between the height at the top of the blade edge and the channel of the jig where the top of the specimen rests when being nicked is measured to ensure the proper setting of the blade.

NOTE 13—Where it is desired to nick specimens to a notch depth required by Conditions B and C in Table 1 and the available jig has been designed for nicking specimens to a notch depth required by Condition A in Table 1, brass shim stock 0.21 mm (0.008 in.) thick may be used to make the more shallow notch. Brass shim stock is cut wide enough so that it fits snugly inside the jig channel where the specimen rests when nicked. The length of the shim should be such that it extends over the blade, around the end of the jig, and under the end so that the jig will rest on about 1 or 2 in. of the shim stock. The weight of the jig resting on the shim stock prevents deformation of the shim stock during the nicking operation. An oblong hole long enough to fit completely over the protruding blade is cut in the other end of the shim stock. Discard shim stock that becomes wrinkled or deformed in such a way as to prevent the specimen from lying horizontal in the jig.

NOTE 14—In order to maintain notch consistency, it is recommended to keep the force applied to the jig handle constant. This can be done by applying the force at the same location of the jig handle each time using a torque wrench.

TABLE 2 ESCR of Polyethylene, F_{50} in Hours

Sample	Ave. F_{50} , h	S_r	S_R	r	R	S_r/X	S_R/X
Resin A, molded plaques	49.6	3.7	19.1	10.5	54.1	7.5 %	39 %
0.945/0.3 extruded sheets	52.7	2.3	28.8	6.5	81.5	4.4 %	55 %
Resin B, molded plaques	42.0	3.4	14.2	9.6	40.2	8.1 %	34 %
0.950/0.06 extruded sheets	49.1	8.0	14.2	22.6	40.2	16 %	29 %

NOTE 15—The notch depth correlates with the depth of blade setting, which is measured by a depth micrometer (see 10.2). The notch depth can be verified by microtoming the cross section of the specimen followed by examining the slice under microscope. It also can be done by fracturing a notched specimen after it is cooled with liquid nitrogen then examine the fracture surface under microscope.

NOTE 16—Check notch quality for straight edge, sharp notch and free of stress concentration area by examining the cross section of the specimen under microscope equipped with a polarized light.

10.3 Inspect the edge of the blade for notches and burrs under normal vision prior to the first nicking and at least after each 30 successive nicks have been performed. In no case shall a blade be used for more than 100 specimens. Replace the blade whenever there is any question of its having become dull or damaged.

10.4 Place ten specimens, with the controlled imperfection up, in the slots provided in the bending clamp. Close the clamp by means of a vise, arbor press, or other suitable aid, taking 30 to 35 s for the complete closing operation. Place the transfer tool in position on top of the closed clamp and close it over the specimens. Then lift the specimens from the clamp with the transfer tool and place them in the channel by releasing the transfer tool. The ends of all the specimens should rest against the base of the brass channel. If some specimens are riding too high in the holder they should be forced down by manual pressure.

10.5 Not more than 10 min after the specimens have been bent into the holder, insert the holder in the test tube. Then immediately fill the tube to approximately 13 mm (0.5 in.) above the top specimen with fresh reagent which is at a temperature of $23 \pm 1^\circ\text{C}$ ($73.4 \pm 1.8^\circ\text{F}$). Stopper the tube with a foil-wrapped cork and immediately place it in the constant-temperature bath at the preselected test temperature. The controlled imperfections should not be touching the test tube during the test.

NOTE 17—The heat capacity and the heat input capacity of the bath should be high enough so that the temperature does not drop more than 1°C when the samples are added.

10.6 Inspect the test specimen at indicated elapsed times and record the total number of failures at the time.

10.7 Obtain the failure point in one of the following three ways:

10.7.1 Percentage of failure at the end of the intervals specified for the material under test, for example, 50 % failure at 24 h.

10.7.2 Estimated failure time in hours when a percentage of failure occurs by observation. This is designated as fp where p is the percentage of specimen failure. f_{50} will be the time when the fifth specimen fails in a ten-specimen test.

10.7.3 Estimated failure time in hours when a percentage of failure occurs by graphical calculation as described in Annex A1. This is designated as Fp where p is the percentage of specimen failure. F_{50} will be the calculated time at the 50 % line on the probability graph.

11. Routine Inspection and Acceptance

11.1 For routine inspection of materials it shall be satisfactory to accept lots on the basis of testing at least ten specimens for a specified time.

12. Report

12.1 Report the following information:

12.1.1 Complete identification of material tested,

12.1.2 Manner of preparation of test sheets (that is, from granules or from milled crepe),

12.1.3 Reagent and strength,

12.1.4 Condition of test from Table 1,

12.1.5 Duration of test in hours,

12.1.6 Percentage of specimens that fail at a designated time, estimated failure time in hours by observation (fp), or estimated failure time in hours by graphical calculation (Fp).

12.1.7 Date of test.

13. Precision and Bias⁶

13.1 *Precision*—Table 2 is based on a round robin conducted in 1995 in accordance with Practice E691, involving five materials tested by seven laboratories. Each material was compression molded by one laboratory and the individual specimens were cut and notched by the laboratory that tested them. Each material was tested twice by each laboratory.

⁶ Supporting data have been filed at ASTM International Headquarters and may be obtained by requesting Research Report RR:D20-1200.