



Designation: **D5918 – 06 D5918 – 13**

## Standard Test Methods for Frost Heave and Thaw Weakening Susceptibility of Soils<sup>1</sup>

This standard is issued under the fixed designation D5918; the number immediately following the designation indicates the year of original adoption or, in the case of revision, the year of last revision. A number in parentheses indicates the year of last reapproval. A superscript epsilon ( $\epsilon$ ) indicates an editorial change since the last revision or reapproval.

### 1. Scope\*

1.1 These laboratory test methods cover the frost heave and thaw weakening susceptibilities of soil that is tested in the laboratory by comparing the heave rate and thawed bearing ratio<sup>2</sup> with values in an established classification system. This test was developed to classify the frost susceptibility of soils used in pavements. It should be used for soils where frost-susceptibility considerations, based on particle size such as the limit of 3 % finer than 20 mm in Specification D2940, are uncertain. This is most important for frost-susceptibility criteria such as those used by the Corps of Engineers,<sup>3</sup> that require a freezing test for aggregates of inconclusive frost classification. The frost heave susceptibility is determined from the heave rate during freezing. The thaw weakening susceptibility is determined with the bearing ratio test (see Test Method D1883).

1.2 This is an index test for estimating the relative degree of frost-susceptibility of soils used in pavement systems. It cannot be used to predict the amount of frost heave nor the strength after thawing, nor can it be used for applications involving long-term freezing of permafrost or for foundations of refrigerated structures.

1.3 The test methods described are for one specimen and uses manual temperature control. It is suggested that four specimens be tested simultaneously and that the temperature control and data taking be automated using a computer.

1.4 All recorded and calculated values shall conform to the guide for significant digits and rounding established in Practice D6026.

1.4.1 The procedures used to specify how data are collected/recorded and calculated in this standard are regarded as the industry standard. In addition, they are representative of the significant digits that should generally be retained. The procedures used do not consider material variation, purpose for obtaining the data, special purpose studies, or any considerations for the user's objectives; and it is common practice to increase or reduce significant digits of reported data to be commensurate with these considerations. It is beyond the scope of this standard to consider significant digits used in analysis methods for engineering design.

1.4.2 Measurements made to more significant digits or better sensitivity than specified in this standard shall not be regarded a nonconformance with this standard.

1.5 This standard is written using SI units. Inch-pound units are provided for convenience. The values stated in inch pound units may not be exact equivalents; therefore, they shall be used independently of the SI system. Combining values from the two systems may result in nonconformance with this standard.

1.5.1 The gravitational system of inch-pound units is used when dealing with inch-pound units. In this system, the pound (lbf) represents a unit of force (weight), while the unit for mass is slugs. The rationalized slug unit is not given, unless dynamic ( $F=ma$ ) calculations are involved.

1.5.2 It is common practice in the engineering/ construction profession to concurrently use pounds to represent both a unit of mass (lbm) and of force (lbf). This implicitly combines two separate systems of units; that is, the absolute system and the gravitational system. It is scientifically undesirable to combine the use of two separate sets of inch-pound units within a single standard. As stated, this standard includes the gravitational system of inch-pound units and does not use/present the slug unit for mass. However, the use of balances or scales recording pounds of mass (lbm) or recording density in  $\text{lbm}/\text{ft}^3$  shall not be regarded as nonconformance with this standard.

<sup>1</sup> These test methods are under the jurisdiction of ASTM Committee D18 on Soil and Rock and are the direct responsibility of Subcommittee D18.19 on Frozen Soils and Rock.

Current edition approved Nov. 1, 2006; Feb. 1, 2013. Published December 2006; March 2013. Originally approved in 1996. Last previous edition approved in 2004; 2006 as D5918-96(2001); D5918-06. DOI: 10.1520/D5918-06; 10.1520/D5918-13.

<sup>2</sup> Sometimes called California Bearing Ratio (CBR).

<sup>3</sup> The Army Corps of Engineers uses a frost susceptibility classification procedure (TM 5-818-2) based on particle size criteria and the Unified Soil Classification System (MIL-STD-619) field. Furthermore, this test should only be used for seasonal freezing and thawing conditions and not for long-term freezing of permafrost or of foundations of refrigerated structures.

\*A Summary of Changes section appears at the end of this standard

1.6 This standard does not purport to address all of the safety concerns, if any, associated with its use. It is the responsibility of the user of this standard to establish appropriate safety and health practices and determine the applicability of regulatory limitations prior to use.

## 2. Referenced Documents

### 2.1 ASTM Standards:<sup>4</sup>

- C670 Practice for Preparing Precision and Bias Statements for Test Methods for Construction Materials
- D75 Practice for Sampling Aggregates
- D420 Guide to Site Characterization for Engineering Design and Construction Purposes (Withdrawn 2011)<sup>5</sup>
- D653 Terminology Relating to Soil, Rock, and Contained Fluids
- D698 Test Methods for Laboratory Compaction Characteristics of Soil Using Standard Effort (12 400 ft-lbf/ft<sup>3</sup> (600 kN-m/m<sup>3</sup>))
- D1587 Practice for Thin-Walled Tube Sampling of Soils for Geotechnical Purposes
- D1883 Test Method for CBR (California Bearing Ratio) of Laboratory-Compacted Soils
- D2216 Test Methods for Laboratory Determination of Water (Moisture) Content of Soil and Rock by Mass
- D2940 Specification for Graded Aggregate Material For Bases or Subbases for Highways or Airports
- D3550 Practice for Thick Wall, Ring-Lined, Split Barrel, Drive Sampling of Soils
- D3740 Practice for Minimum Requirements for Agencies Engaged in Testing and/or Inspection of Soil and Rock as Used in Engineering Design and Construction
- D4083 Practice for Description of Frozen Soils (Visual-Manual Procedure)
- D6026 Practice for Using Significant Digits in Geotechnical Data
- E105 Practice for Probability Sampling of Materials
- E122 Practice for Calculating Sample Size to Estimate, With Specified Precision, the Average for a Characteristic of a Lot or Process

### 2.2 Military Standards:<sup>6</sup>

- Army TM 5-818-2 Pavement Design for Frost Conditions, January 1985
- MIL-STD-619 Unified Soil Classification System for Roads, Airfields, Embankments and Foundations

## 3. Terminology

### 3.1 Definitions:

3.1.1 Definitions of the soil components of a freezing and thawing soil system shall be in accordance with the terminology in For definitions of common technical terms in this standard, refer to Terminology D653.

3.1.2 Definitions of the components of freezing and thawing soils shall be in accordance with the terminology in Practice D4083.

### 3.2 Definitions of Terms Specific to This Standard: ASTM D5918-13

3.2.1 The following terms are used in conjunction with the determination of the frost-susceptibility of soils and supplement those in Practice D4083 and in the glossary on permafrost terms by Harris et al.<sup>7</sup>

3.2.1.1 *degree of frost-susceptibility*—the relative propensity for frost heave or thaw weakening in comparison to that for another soil or to an acceptable level of change.

3.2.1.2 *freeze-thaw cycling*—the repeated freezing and thawing of soil.

3.2.1.3 *freezing (soil)*—the changing of phase from water to ice in soil.

3.2.1.4 *freezing, closed system*—freezing that occurs under conditions that preclude the gain or loss of any water in the system.

3.2.1.5 *freezing, open system*—freezing that occurs under conditions that allow gain or loss of water in the system by movement of pore water from or to an external source to growing ice lenses.

3.2.1.6 *freezing-point depression*—the number of degrees by which the freezing point of an earth material is depressed below the freezing point of pure water.

3.2.1.7 *frost heave*—the upward or outward movement of the ground or pavement surface (in the direction of heat flow) caused by the formation of ice in the soil.

3.2.1.8 *frost heave rate*—the rate at which the ground or pavement surface moves upward or outward.

3.2.1.9 *frost heave susceptibility*—the propensity for a soil to accumulate ice during freezing and to heave.

<sup>4</sup> For referenced ASTM standards, visit the ASTM website, [www.astm.org](http://www.astm.org), or contact ASTM Customer Service at [service@astm.org](mailto:service@astm.org). For *Annual Book of ASTM Standards* volume information, refer to the standard's Document Summary page on the ASTM website.

<sup>5</sup> The last approved version of this historical standard is referenced on [www.astm.org](http://www.astm.org).

<sup>6</sup> Available from Superintendent of Documents, U.S. Government Printing Office, Washington, DC 20402.

<sup>7</sup> Harris, S. A. et al. *Glossary of Permafrost and Related Ground-Ice Terms*, Permafrost Subcommittee, Associate Committee on Geotechnical Research, National Research Council of Canada, Technical Memorandum No. 142, Available from National Research Council of Canada, Ottawa, Ontario, Canada, K1A0R6, 1988; Harris, S. A., et al., *Glossary of Permafrost and Related Ground-Ice Terms*, Permafrost Subcommittee, Associate Committee on Geotechnical Research, National Research Council of Canada, Technical Memorandum No. 142, Available from National Research Council of Canada, Ottawa, Ontario, Canada, K1A0R6, 1988.

3.2.1.10 *frost-susceptible soil*—soil in which ice accumulation causes frost heave during freezing or thaw weakening during thawing, or both.

3.2.1.11 *ice lens*—a lens-shaped body of ice of any dimension that forms during unidirectional freezing of soil, the long dimension being in the direction normal to the direction of heat flow.

3.2.1.12 *ice nucleation*—the formation of an ice nucleus from water.

3.2.1.13 *refrigerated structures*—artificially refrigerated structures (cold storage facilities, liquefied gas tanks, ice skating rinks, chilled gas pipelines, and so forth) that cause the freezing of their foundations.

3.2.1.14 *relative frost susceptibility*—the amount of frost heave or thaw weakening of a soil in relation to other soils.

3.2.1.15 *seasonally frozen ground*—ground that freezes and thaws annually.

3.2.1.16 *thaw weakening*—the reduction in strength, bearing capacity, or stiffness modulus below the normal warm-season values. This is caused by the decrease in effective stress resulting from the generation and slow dissipation of excess pore water pressures when frozen soils containing ice are thawing.

3.2.1.17 *thaw weakening susceptibility*—the propensity for the strength or stiffness modulus of a soil to decrease below the normal warm season values.

3.2.1.18 *unidirectional freezing*—soil freezing that occurs in one direction only.

#### 4. Summary of Test Methods

4.1 Two freeze-thaw cycles are imposed on compacted soil specimens, 146 mm (5.75 in.) in diameter and 150 mm (6 in.) in height. The soil specimen is frozen and thawed by applying specified constant temperatures in steps at the top and bottom of the specimen, with or without water freely available at the base; a surcharge of 3.5 kPa (0.5 lbf/in.) is applied to the top. The temperatures imposed on the specimen are adjusted to take into account the freezing point depression attributable to salts in the soil. At the end of the second thawing cycle, the bearing ratio is determined. The entire testing procedure can be completed within a five-day period. This testing procedure may be conducted manually or it may be controlled by a computer.

NOTE 1—The quality of the results produced by this standard is dependent on the competence of the personnel performing it, and the suitability of the equipment and facilities. Agencies that meet the criteria of Practice D3740 are generally considered capable of competent and objective testing/sampling/inspection/etc. Users of this standard are cautioned that compliance with Practice D3740 does not in itself assure reliable results. Reliable results depend on many factors; Practice D3740 provides a means of evaluating some of those factors.

#### 5. Significance and Use

5.1 These test methods can be used to determine the relative frost-susceptibility of soils used in pavement systems. Both the frost heave susceptibility and the thaw weakening susceptibility can be determined.

5.2 These test methods should be used only for seasonal frost conditions and not for permanent or long-term freezing of soil. These test methods also have not been validated for anything other than pavement systems.

5.3 These test methods cannot be used to predict the amount of frost heave or thaw weakening in the field. Its purpose is to determine the relative frost-susceptibility classification for use in empirical pavement design methods for seasonal frost regions.

NOTE 1—The quality of the result produced by this standard is dependent on the competence of the personnel performing it, and the suitability of the equipment and facilities used. Agencies that meet the criteria of Practice D3740 are generally considered capable of competent and objective testing/sampling/inspection/etc. Users of this standard are cautioned that compliance with Practice D3740 does not in itself assure reliable results. Reliable results depend on many factors; Practice D3740 provides a means of evaluating some of those factors.

#### 6. Apparatus

6.1 *Compaction Mold*—The mold assembly (see Fig. 1) shall consist of a steel base plate, a steel hollow cylinder split into three sections longitudinally, two acrylic spacer disks, six acrylic rings, a steel collar, a rubber membrane, and four hose clamps.

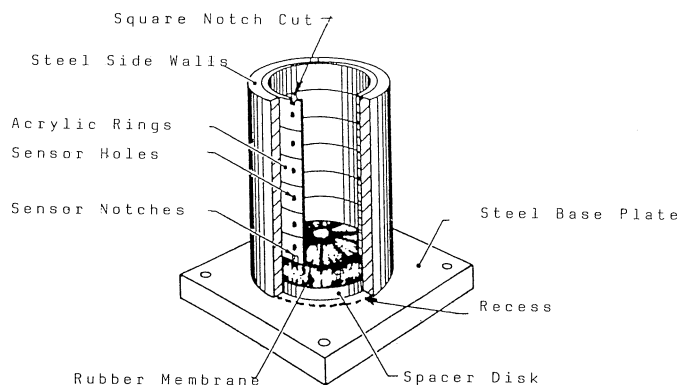

FIG. 1 Compaction Mold Assembly

6.1.1 *Base Plate*—A 203-mm (8-in.) square steel base plate (see Fig. 1) with a thickness of 25 mm (1.0 in.) and a 6.0-mm (0.25-in.) recess to receive and retain the steel side walls and base of the specimen. Two 9.5-mm (0.375-in.) diameter threaded holes at opposite corners accommodate clamping rods.

6.1.2 *Compaction Cylinder*—A hollow steel cylinder with an inside diameter of 152.4 mm (6 in.), a wall thickness of 9.5 mm (0.375 in.), and a length of 165.1 mm (6.5 in.). The cylinder is to be made in three sections that part along the vertical axis (see Fig. 1). A recess in the steel base plate accepts the steel cylinder and restrains it from expanding during compaction.

6.1.3 *Collar*—A steel collar with a 146-mm (5.75-in.) inside diameter and a 185-mm (7.25-in.) outside diameter with a 152.4-mm (6-in.) diameter recess bored 6.35 mm (0.25 in.) into the bottom. This collar slips over the top of the steel mold to constrain expansion and to provide extra space for soil during compaction. Flanges slide over the steel rods to hold the collar in place.

6.1.4 *Spacer Disk*—Two circular acrylic spacer disks (see Fig. 1), 158.8 mm (6.25 in.) in diameter and 6.4 mm (0.25 in.) in height. One spacer disk is placed at the bottom of the compaction mold. The second disk is placed on the top of the specimen during transport and storage.

6.1.5 *Rings*—Six acrylic rings (see Fig. 1 and Fig. 2) having an inside diameter of 146 mm (5.75 in.) and a height of 25 mm (1 in.) with a wall thickness of 3.18 mm (0.125 in.). A 3.18-mm diameter hole shall be drilled at the mid-height in each ring to receive a temperature sensor. The top and bottom rings shall have a 3.18-mm square notch cut in one edge to receive the top and bottom temperature sensor leads. Each ring shall have a split cut through its height at a location diametrically opposite the temperature sensor hole.

6.1.6 *Clamping Rods*—Two 9.5-mm (0.375-in.) diameter by 215.9-mm (8.5-in.) long threaded steel rods with two wing nuts to clamp the assembly together.

6.1.7 *Rubber Membrane*—A 0.36-mm (0.014-in.) thick rubber membrane without holes or defects. This is required to seal the sides of a soil specimen that shall be 146.0 mm (5.25 in.) in diameter. The length of the membrane shall be at least 203.0 mm (8.0 in.).

6.1.8 *Clamps*—Four hose clamps to hold the steel side walls together. The outside diameter of the side walls are to be 168.0 mm (6.75 in.).

6.2 *Specimen Freezing Assembly*—The apparatus for freezing the soil specimen (see Fig. 2) shall consist of temperature-controlled top and bottom plates, a specimen base plate with a porous stone and two ports for water supply and flushing (filter paper is placed between the stone and the specimen bottom), six acrylic rings stacked to form a cylinder and a rubber membrane to contain the soil specimen, a temperature-controlled top plate; a surcharge weight, a constant head (Mariotte) water supply, an assembly to support the displacement measuring system, and a displacement transducer or dial extensometer, or both.

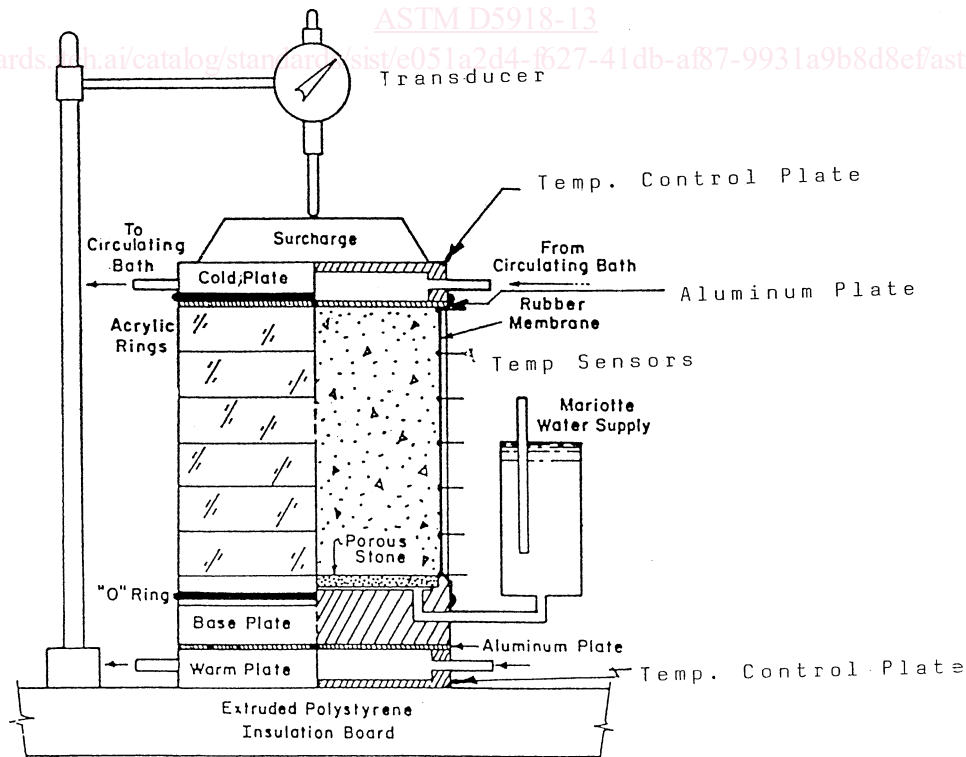

FIG. 2 specimen Assembly for Freezing Test

6.2.1 *Top and Bottom Temperature Control End Plates*—The temperature control end plates (see Fig. 2) shall be fabricated from reinforced phenolic resin, with an aluminum plate cover to provide heat-conductive surfaces contiguous to the top of the soil specimen and to the bottom of the base plate. The phenolic resin component of the end plates shall be machined so that the cooling (or heating) liquid entering each end plate shall follow a serpentine path and exit at a point diametrically opposite the entrance point.

6.2.2 *Specimen Base Plate*—The circular aluminum base plate (see Fig. 2) is to be 150 mm (6 in.) in diameter and 38 mm (1.5 in.) in height. The top of the base plate is to have two concentric circular recesses in its top surface to hold a circular porous stone or a stainless steel porous disk. One recess is to be 138.1 mm (5.4 in.) in diameter and have a depth of 6 mm (0.25 in.). The second recess is to have a diameter of 125.4 mm (4.94 in.) and a depth of 9.5 mm (0.375 in.) to facilitate access of the water supply to the underside of the porous stone (or disk). The base plate is to have two ports diametrically opposite, connecting to the deepest recess in the base (see Fig. 2). One port is to be connected to the external water supply reservoir; the second port is used to drain water and to flush air from beneath the porous stone (disk).

6.2.3 *Rings*—Same as 6.1.4.

6.2.4 *Constant Head (Mariotte) Water Supply*—The water supply reservoir is to consist of a clear acrylic plastic tube that has an inside diameter of at least 57 mm (2.25 in.) and a height of 508 mm (20.0 in.) (see Fig. 2). The top and bottom of the reservoir are sealed. The top is removable to allow filling with water. The bottom of the reservoir is connected to the inlet port on the specimen base plate with a flexible plastic tube. A hose clamp is used to open or shut off the flow of water. A glass tube (called a bubble tube), with an inside diameter of about 3 mm (0.125 in.) and a length of 533 mm (21.0 in.), is placed through a vacuum-tight vacuum-tight fitting in the top of the tube. A second flexible tube is connected to the drain port on the specimen base plate. When water flows out of the reservoir tube to the specimen, air fills the bubble tube and the water head becomes fixed at the bottom of the bubble tube. When water flows out of the specimen, the water head remains at the bottom of the bubble tube as long as the drain tube is open and is positioned at the same elevation as the bottom of the bubble tube. The water head elevation is adjusted by raising or lowering the reservoir tube and the drain tube. A transparent scale, attached to the side of the reservoir tube, allows tracking the water flow. The flow rate can also be followed electronically with a pressure transducer.

6.2.5 *Surcharge Weight*—The surcharge weight is a circular lead disk having a mass of 5.5 of 5.5 kg (10.0 lb) with an outside diameter of 142.0 mm (5.6 in.) that is placed on top of the test specimen.

6.2.6 *Heave and Consolidation Measuring Apparatus*—A vertical post with a minimum diameter of 16 mm (0.625 in.) and a minimum height of 508 mm (20 in.) fixed to the base plate of the test specimen, shall provide support for an adjustable arm to hold the displacement dial gage or displacement transducer, or both (see Fig. 2). The dial gages and displacement transducers shall be capable of measuring vertical movements of 25.4 mm (1.0 in.) with an accuracy of 0.025 mm (0.001 in.). The transducers must be calibrated frequently. This can easily be done for each test if a dial gage is coupled to the displacement transducer as shown in Fig. 2.

6.3 *Temperature Control Baths*—Two sources of temperature-controlled circulating liquid, such as an ethylene glycol-water 50 % solution, are required. One source is to be used to control the temperature of the top temperature control plate and the second source is to control the temperature of the bottom temperature control plate. Both sources shall have a controllable temperature range from  $-15^{\circ}\text{C}$  ( $5^{\circ}\text{F}$ ) to  $15^{\circ}\text{C}$  ( $59^{\circ}\text{F}$ ) and be capable of maintaining the temperature at each temperature control plate to within  $+0.2^{\circ}\text{C}$  ( $0.4^{\circ}\text{F}$ ) of the preset temperatures.

6.4 *Temperature Control Chamber*—The temperature control chamber in which the freeze-thaw tests are to be conducted shall have inside dimensions that will house the test specimen freezing assembly. Fig. 3 shows a  $0.35\text{-m}^3$  ( $12\text{-ft}^3$ ) capacity chest-type freezer adapted to accommodate four test specimens. A refrigerator or cold room could also be used. The cold chamber shall have the capability of maintaining the ambient air temperature around the test specimen assemblies at  $2^{\circ}\text{C}$  ( $35.6^{\circ}\text{F}$ ) within  $\pm 1.0^{\circ}\text{C}$  ( $2^{\circ}\text{F}$ ).

6.5 *Temperature Measuring System*—The temperature measuring system shall have a range from  $-15^{\circ}\text{C}$  ( $5.0^{\circ}\text{F}$ ) to  $15^{\circ}\text{C}$  ( $59.0^{\circ}\text{F}$ ) and shall be capable of measuring temperatures within  $\pm 0.1^{\circ}\text{C}$  ( $0.2^{\circ}\text{F}$ ). The temperature sensors shall be small enough [less than 3.2 mm (0.125 in.)] to permit their insertion into the soil test specimen with a minimum of disturbance to the soil (see Fig. 4). The temperature readings are to be taken periodically and may be taken manually. It is preferable that the temperatures be read with an automated data logging system.

6.6 *Miscellaneous Apparatus*—Other general apparatus such as a mixing bowl, straightedge, scales, oven, filter paper, test tubes, loose insulation, and dishes are required.

## 7. Soil Sampling and Preparation

7.1 Use intact soil samples when possible. Intact specimens usually can only be prepared for fine-grained soils, in particular competent silt and clay soils found in the subgrade of roads. Where the soil is to be remolded and compacted in the field, use laboratory-compacted soils. In all cases, the sampling procedures should be in accordance with Practices D420 and D75. Recommendations for obtaining representative specimens in Practices E105 and E122 should also be considered. specimens Specimens are obtained and prepared as follows:

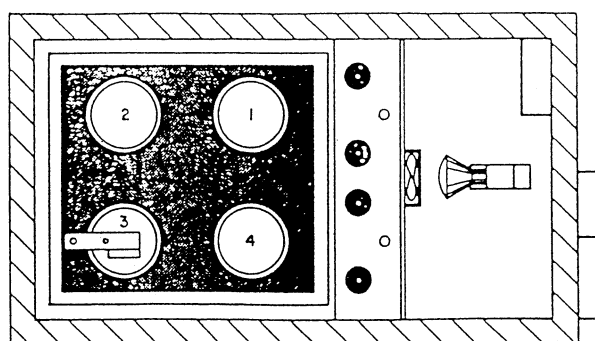

PLAN VIEW

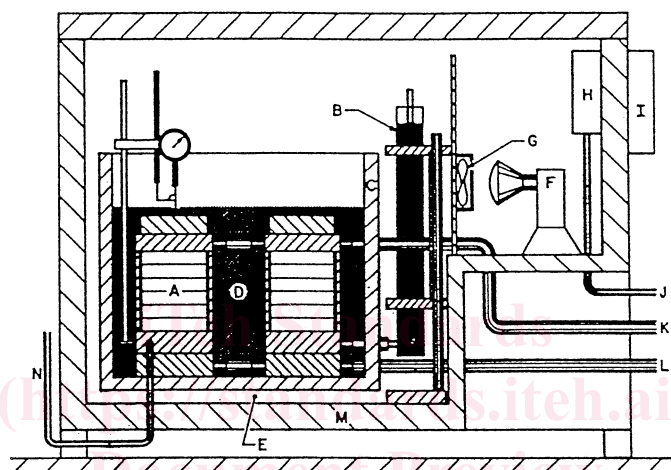

PROFILE

A = specimen assembly  
 B = water supply  
 C = rigid insulation  
 D = granular insulation  
 E = ambient air space  
 F = heat source  
 G = fan

H = electronics panel  
 I = air temperature controller  
 J = lines to datalogger  
 K = top plate circulation tubing  
 L = bottom plate circulation tubes  
 M = freezer chest  
 N = drainage lines

FIG. 3 Freeze Cabinet Assembly for Freezing Test

7.1.1 *Intact Samples*—Obtain intact samples in accordance with Practice D1587 using a thin-walled tube, in accordance with Practice D3550 using a ring-lined barrel specimen, specimen, or by cutting specimens from blocks of soil obtained by careful field sampling. Place the specimens in sealed containers to minimize loss of moisture and mechanical damage during transport and storage. Determine the water content in accordance with Test Method D2216 on about 500 g (1.1 lb) of trimmings or adjacent specimens. Record the method of sampling and water content.

7.1.2 *Remolded Samples*—The dry density and moisture content required for the test should be determined from analysis of in situ conditions or from a compaction test such as Test Method D698. The project requirements determine the moisture-density specifications. Select a representative specimen in accordance with Test Method C670 weighing approximately 6.0 kg (13.6 lb) and mix it well; then determine the water content following Test Method D2216 on a 500-g (1.1-lb) subsample. Adjust the moisture content of the remaining soil to the desired compaction value and allow the specimen to condition for 24 h in a closed container. Prepare the specimen to the desired dry unit weight in accordance with the procedure given under Section 8 using the mold assembly shown in Fig. 1. The method used shall be noted in the report. Record the method of sampling and water content.

## 8. Specimen Preparation

8.1 *Intact Samples*—Carefully trim the core or block sample obtained from the field to 171.5 mm (6.75 in.) in diameter and 152.4 mm (6.0 in.) in height. A special jig, using a wire saw or a sharp straightedge and a trimming guide, will facilitate this process. Leave the final trimming of the ends until after the acrylic rings are in place. Determine the mass of the rings (with filament tape for closure), membrane, and two acrylic disks together, and record the results. Set the specimen on an acrylic base