

FINAL
DRAFT

INTERNATIONAL
STANDARD

ISO/FDIS
23337

ISO/TC 45/SC 2

Secretariat: JISC

Voting begins on:
2023-10-31

Voting terminates on:
2023-12-26

Rubber, vulcanized or thermoplastic — Determination of abrasion resistance using the Improved Lambourn test machine

*Caoutchouc vulcanisé ou thermoplastique — Détermination de
la résistance à l'abrasion à l'aide d'une machine de Lambourn
perfectionnée*

iteh standards
(<https://standards.iteh.ai>)
Document Preview

[ISO/FDIS 23337](#)

<https://standards.iteh.ai/catalog/standards/sist/a156550f-3e86-4269-9d29-34468cb70afa/iso-fdis-23337>

RECIPIENTS OF THIS DRAFT ARE INVITED TO SUBMIT, WITH THEIR COMMENTS, NOTIFICATION OF ANY RELEVANT PATENT RIGHTS OF WHICH THEY ARE AWARE AND TO PROVIDE SUPPORTING DOCUMENTATION.

IN ADDITION TO THEIR EVALUATION AS BEING ACCEPTABLE FOR INDUSTRIAL, TECHNOLOGICAL, COMMERCIAL AND USER PURPOSES, DRAFT INTERNATIONAL STANDARDS MAY ON OCCASION HAVE TO BE CONSIDERED IN THE LIGHT OF THEIR POTENTIAL TO BECOME STANDARDS TO WHICH REFERENCE MAY BE MADE IN NATIONAL REGULATIONS.



Reference number
ISO/FDIS 23337:2023(E)

© ISO 2023

iTeh Standards
(<https://standards.iteh.ai>)
Document Preview

[ISO/FDIS 23337](https://standards.iteh.ai/catalog/standards/sist/a156550f-3e86-4269-9d29-34468cb70afa/iso-fdis-23337)

<https://standards.iteh.ai/catalog/standards/sist/a156550f-3e86-4269-9d29-34468cb70afa/iso-fdis-23337>



COPYRIGHT PROTECTED DOCUMENT

© ISO 2023

All rights reserved. Unless otherwise specified, or required in the context of its implementation, no part of this publication may be reproduced or utilized otherwise in any form or by any means, electronic or mechanical, including photocopying, or posting on the internet or an intranet, without prior written permission. Permission can be requested from either ISO at the address below or ISO's member body in the country of the requester.

ISO copyright office
CP 401 • Ch. de Blandonnet 8
CH-1214 Vernier, Geneva
Phone: +41 22 749 01 11
Email: copyright@iso.org
Website: www.iso.org

Published in Switzerland

Contents

Page

Foreword	iv
Introduction	v
1 Scope	1
2 Normative references	1
3 Terms and definitions	1
4 Principle	2
5 Apparatus	3
5.1 Abrasion test machine.....	3
5.2 Balance.....	4
6 Calibration	4
7 Test pieces	4
7.1 Type and preparation.....	4
7.2 Number.....	5
7.3 Time interval between vulcanization and testing.....	5
8 Test conditions	5
9 Procedure	6
9.1 Preliminary wear.....	6
9.2 Abrasion test.....	6
9.3 Density.....	6
10 Expression of results	6
11 Precision	7
12 Test report	7
Annex A (informative) Precision	8
Annex B (normative) Calibration schedule	10
Bibliography	12

Foreword

ISO (the International Organization for Standardization) is a worldwide federation of national standards bodies (ISO member bodies). The work of preparing International Standards is normally carried out through ISO technical committees. Each member body interested in a subject for which a technical committee has been established has the right to be represented on that committee. International organizations, governmental and non-governmental, in liaison with ISO, also take part in the work. ISO collaborates closely with the International Electrotechnical Commission (IEC) on all matters of electrotechnical standardization.

The procedures used to develop this document and those intended for its further maintenance are described in the ISO/IEC Directives, Part 1. In particular, the different approval criteria needed for the different types of ISO document should be noted. This document was drafted in accordance with the editorial rules of the ISO/IEC Directives, Part 2 (see www.iso.org/directives).

ISO draws attention to the possibility that the implementation of this document may involve the use of (a) patent(s). ISO takes no position concerning the evidence, validity or applicability of any claimed patent rights in respect thereof. As of the date of publication of this document, ISO had not received notice of (a) patent(s) which may be required to implement this document. However, implementers are cautioned that this may not represent the latest information, which may be obtained from the patent database available at www.iso.org/patents. ISO shall not be held responsible for identifying any or all such patent rights.

Any trade name used in this document is information given for the convenience of users and does not constitute an endorsement.

For an explanation of the voluntary nature of standards, the meaning of ISO specific terms and expressions related to conformity assessment, as well as information about ISO's adherence to the World Trade Organization (WTO) principles in the Technical Barriers to Trade (TBT), see www.iso.org/iso/foreword.html.

This document was prepared by Technical Committee ISO/TC 45, *Rubber and rubber products*, Subcommittee SC 2, *Testing and analysis*.

This third edition cancels and replaces the second edition (ISO 23337:2016), which has been technically revised.

The main changes are as follows:

- an optional test piece thickness has been added.

Any feedback or questions on this document should be directed to the user's national standards body. A complete listing of these bodies can be found at www.iso.org/members.html.

Introduction

Various types of laboratory test equipment for determining the wear resistance of rubber compounds have been developed, depending on the products to which rubber compounds have been applied in the past. One such piece of equipment, called the “Improved Lambourn” abrasion test machine, is briefly introduced with other types in ISO 23794^[3] and the test method for using it is described in detail in this document.

The main features of the Improved Lambourn machine are as follows.

- a) The slip rate is adjustable by virtue of the fact that the abrasive wheel and test piece are driven separately. A servo-mechanism is used for driving both the abrasive wheel and the test piece to ensure accurate speed control. In older types of equipment, both the abrasive wheel and the test piece were driven by the same drive system, with the speeds of rotation controlled by braking systems, which could result in an inaccurately controlled slip rate.
- b) A controlled feed of carborundum grit to the nip between the rubber test piece and the abrasive wheel ensures that abraded particles are prevented from adhering to the surface of the test piece or abrasive wheel, which is important in obtaining reproducible test results.

A previous wear study for rubber compounds using the Improved Lambourn machine showed that, at higher slip rates, wear resistance decreased in the order: butadiene rubber (BR) base compound, natural rubber (NR) base, styrene-butadiene rubber (SBR) base. However, at low slip rates, the order was reversed. This is interesting since the tread compound in truck and bus tyres generally uses NR or a blend of NR and BR base compound, while SBR base compound is used in car tyres. More details can be found in Reference ^[4].

(<https://standards.iteh.ai>)
Document Preview

[ISO/FDIS 23337](https://standards.iteh.ai/catalog/standards/sist/a156550f-3e86-4269-9d29-34468cb70afa/iso-fdis-23337)

<https://standards.iteh.ai/catalog/standards/sist/a156550f-3e86-4269-9d29-34468cb70afa/iso-fdis-23337>

Rubber, vulcanized or thermoplastic — Determination of abrasion resistance using the Improved Lambourn test machine

WARNING 1 — Persons using this document should be familiar with normal laboratory practice. This document does not purport to address all of the safety problems, if any, associated with its use. It is the responsibility of the user to establish appropriate safety and health practices and to determine the applicability of any other restrictions.

WARNING 2 — Certain procedures specified in this document might involve the use or generation of substances, or the generation of waste, that can constitute a local environmental hazard. Reference should be made to appropriate documentation on safe handling and disposal after use.

1 Scope

This document specifies a method for the determination of the resistance of rubber to abrasion using the Improved Lambourn test machine.

The abrasion loss resulting from the slip caused by the difference in circumferential speed between a disc-shaped rubber test piece and an abrasive wheel, which are driven to rotate independently with their circumferences pressed against each other by a specified load, is determined. The test result can be reported as a volume loss per abrasion test time or running distance, and/or as an abrasion resistance index compared to a reference compound.

As the Improved Lambourn test machine is capable of setting various abrasive conditions, such as slip rate, sliding speed and load, independently, this method is suitable for the evaluation of compounds for a range of rubber products, especially tyres, under a wide range of severity conditions. An example of the testing of tyre tread rubber is given in [Annex A](#).

2 Normative references

The following documents are referred to in the text in such a way that some or all of their content constitutes requirements of this document. For dated references, only the edition cited applies. For undated references, the latest edition of the referenced document (including any amendments) applies.

ISO 525, *Bonded abrasive products — Shape types, designation and marking*

ISO 2781, *Rubber, vulcanized or thermoplastic — Determination of density*

ISO 8486-1, *Bonded abrasives — Determination and designation of grain size distribution — Part 1: Macrogrits F4 to F220*

ISO 18899:2013, *Rubber — Guide to the calibration of test equipment*

ISO 23529, *Rubber — General procedures for preparing and conditioning test pieces for physical test methods*

3 Terms and definitions

For the purposes of this document, the following terms and definitions apply.

ISO and IEC maintain terminology databases for use in standardization at the following addresses:

- ISO Online browsing platform: available at <https://www.iso.org/obp>
- IEC Electropedia: available at <https://www.electropedia.org/>

3.1

abrasion

loss of material from a surface due to frictional forces

[SOURCE: ISO 23794:2023, 3.1]

3.2

abrasion resistance

resistance to wear resulting from mechanical action upon a surface

Note 1 to entry: Abrasion resistance is expressed by the abrasion resistance index.

[SOURCE: ISO 23794:2023, 3.2]

3.3

abrasion resistance index

ratio of the loss in volume of a standard rubber to the loss in volume of a test rubber, measured under the same specified conditions and expressed as a percentage

[SOURCE: ISO 23794:2023, 3.3, modified — Note to entry has been omitted.]

3.4

slip rate

ratio of the difference between the circumferential speed of the test piece and that of the abrasion wheel to the circumferential speed of the test piece, expressed as a percentage

3.5

running distance

total distance travelled by a point on the circumference of the test piece, determined from the initial outer diameter of the test piece, its speed of rotation and the abrasion time

3.6

reference compound

compound whose abrasion resistance is to be compared with that of the test rubber

4 Principle

Wear occurs due to the slip caused by the difference in circumferential speed between a disc-shaped rubber test piece and an abrasive wheel rotating against each other for a specified length of time.

The test piece and the abrasive wheel, aligned with their circumferences pressed against each other by a specified load and with their axes of rotation parallel, are driven independently (see [Figure 1](#)).

Grit is fed into the nip between the test piece and the abrasive wheel to prevent smearing of the test piece and the abrasive wheel surface.

The loss in mass of the test piece is determined and the loss in volume per unit abrasion time or running distance is calculated from the density of the test material. The abrasion resistance index, if required, is determined by comparing this loss in volume with the loss in volume of a reference compound tested under the same conditions.

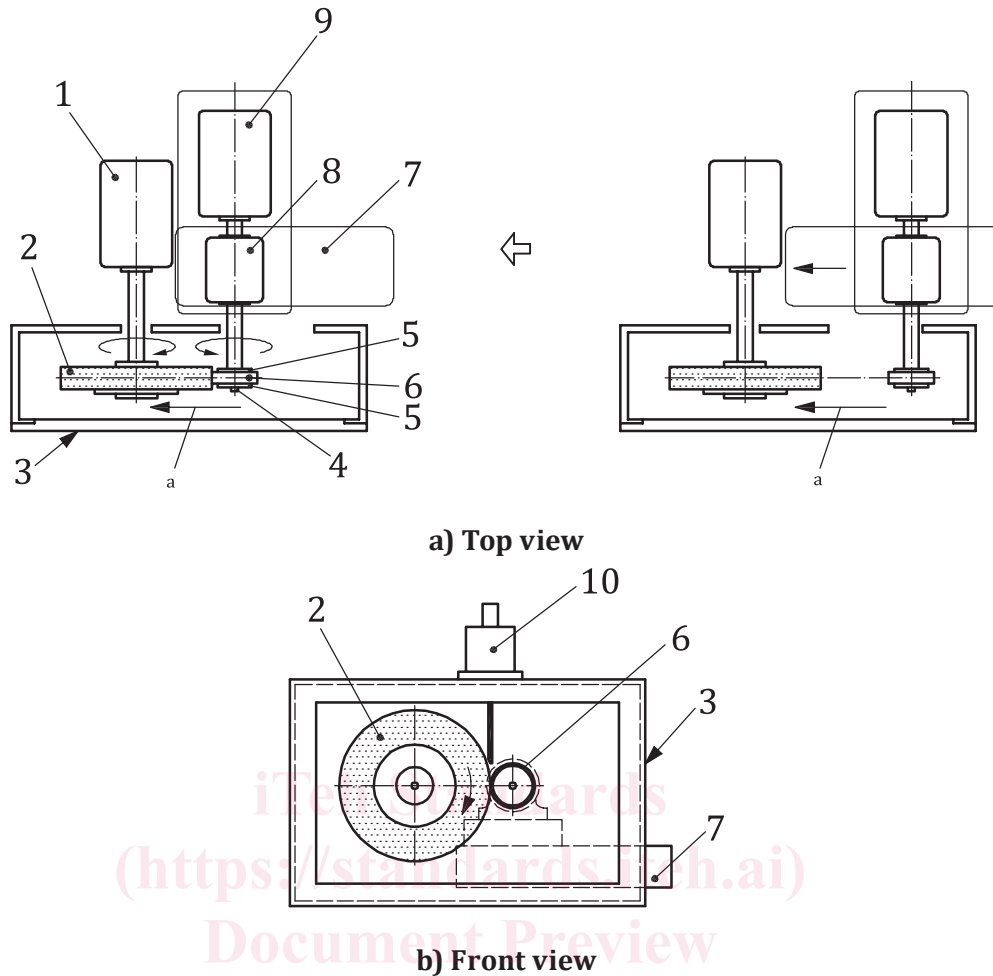
**Key**

- | | | | |
|---|--|----|---|
| 1 | drive motor for abrasive wheel | 6 | test piece |
| 2 | abrasive wheel | 7 | mechanism for exerting load on test piece |
| 3 | test chamber | 8 | torque meter |
| 4 | test piece mounting | 9 | drive motor for test piece |
| 5 | test piece guide | 10 | grit-dropping mechanism |
| a | Test piece pressed against abrasive wheel. | | |

The torque meter fitted to the test piece drive shaft detects any abnormal conditions from torque changes during the test. It shall be capable of measuring torques ranging from 0 N·m to 5 N·m to the nearest 0,01 N·m.

Figure 1 — Schematic illustration of apparatus

5 Apparatus

5.1 Abrasion test machine

The test machine (see [Figure 1](#)) shall consist of a test piece mounting, an abrasive wheel, a drive mechanism to rotate the test piece and the abrasive wheel at different speeds, a loading mechanism to press the test piece against the abrasive wheel at the specified load, a grit-dropping mechanism to prevent smearing of the test piece and the abrasive wheel surface, and a test chamber to prevent grit from spreading and to ensure safety during the test.

The mounting of the test piece shall be designed so that the test piece does not slip on the rotating shaft when torque is applied, in order that the rotational speed of the shaft is accurately transmitted to the

test piece. A pair of disc-shaped test piece guides 4 mm thick and 43 mm or 58,5 mm in diameter shall be fitted each side of the test piece to hold it in place.

The mounting of the abrasive wheel shall be designed so that the abrasive wheel does not slip on the rotating shaft when torque is applied, in order that the rotational speed of the shaft is accurately transmitted to the abrasive wheel. The specifications of the abrasive wheel shall be in accordance with ISO 525: abrasive C (silicon carbide), grit size 80 (equivalent to the designation F80 specified in ISO 8486-1), hardness grade K, nature of bond V (vitrified bond) and maximum operating speed <16 m/s (less than 16 m/s). The diameter of the abrasive wheel shall be 175 mm, 205 mm or 305 mm, with a thickness of 20 mm to 50 mm.

Permissible combinations of the dimensions of the test piece, the test piece guide and the abrasive wheel are given in [Table 1](#).

Table 1 — Permissible combinations of dimensions of the test piece, the test piece guide and the abrasive wheel

Dimensions in millimetres

Combination	Test piece		Test piece guide		Abrasive wheel	
	Diameter	Thickness	Diameter	Thickness	Diameter	Thickness
A	49,0	5,0 or 10,0	43,0	4,0	175,0	20 to 50
B	63,5	5,0 or 10,0	58,5	4,0	205,0	20 to 50
C	49,0	5,0 or 10,0	43,0	4,0	305,0	20 to 50

The drive mechanism shall have two motors, one for the test piece and one for the abrasive wheel, so as to control their circumferential speeds, which shall be between 10 m/min and 200 m/min, independently.

A loading mechanism shall be fitted to press the test piece against the abrasive wheel at the specified load in the range 5 N to 80 N during the test, regardless of the combination of dimensions used.

A mechanism shall be fitted to drop grit at the specified rate into the gap between the test piece and the abrasive wheel. The drop rate shall be adjusted to be in the range 10 g/min to 30 g/min. The type of grit used shall be silicon carbide corresponding to a designation between F80 and F100 as specified in ISO 8486-1.

The cleaning mechanism such as brushing or air jets may apply to prevent clogging or smearing the abrasive wheels.

5.2 Balance

The balance shall be of sufficient accuracy to enable the loss in mass of the test piece to be determined to ± 1 mg.

6 Calibration

The test apparatus shall be calibrated in accordance with the schedule given in [Annex B](#).

7 Test pieces

7.1 Type and preparation

The test pieces shall be disc-shaped, of diameter 49 mm or 63,5 mm and of thickness 5 mm or 10 mm. The test pieces shall be prepared by moulding or by cutting from test sheets or products using a rotary cutter. The surface of the test pieces which is to be abraded shall be smooth.

NOTE For samples with low hardness, 10 mm thickness is more appropriate.