



Designation: A456/A456M – 08 (Reapproved 2013)

Standard Specification for Magnetic Particle Examination of Large Crankshaft Forgings¹

This standard is issued under the fixed designation A456/A456M; the number immediately following the designation indicates the year of original adoption or, in the case of revision, the year of last revision. A number in parentheses indicates the year of last reapproval. A superscript epsilon (ϵ) indicates an editorial change since the last revision or reapproval.

1. Scope

1.1 This is an acceptance specification for the magnetic particle inspection of forged steel crankshafts having main bearing journals or crankpins 4 in. [200 mm] or larger in diameter.

1.2 There are three classes, with acceptance standards of increasing severity:

1.2.1 Class 1.

1.2.2 Class 2 (originally the sole acceptance standard of this specification).

1.2.3 Class 3 (formerly covered in Supplementary Requirement S1 of Specification A456 – 64 (1970)).

1.3 This specification is not intended to cover continuous grain flow crankshafts (see Specification A983/A983M); however, Specification A986/A986M may be used for this purpose.

NOTE 1—Specification A668/A668M is a product specification which may be used for slab-forged crankshaft forgings that are usually twisted in order to set the crankpin angles, or for barrel forged crankshafts where the crankpins are machined in the appropriate configuration from a cylindrical forging.

1.4 The values stated in either SI units or inch-pound units are to be regarded separately as standard. The values stated in each system may not be exact equivalents; therefore, each system shall be used independently of the other. Combining values from the two systems may result in non-conformance with the standard.

1.5 Unless the order specifies the applicable “M” specification designation, the material shall be furnished to the inch units.

¹ This specification is under the jurisdiction of ASTM Committee A01 on Steel, Stainless Steel and Related Alloys, and is the direct responsibility of Subcommittee A01.06 on Steel Forgings and Billets.

Current edition approved April 1, 2013. Published April 2013. Originally approved in 1999. Last previous edition approved in 2008 as A456/A456M – 08. DOI: 10.1520/A0456_A0456M-08R13.

2. Referenced Documents

2.1 *ASTM Standards*:²

A275/A275M Practice for Magnetic Particle Examination of Steel Forgings

A668/A668M Specification for Steel Forgings, Carbon and Alloy, for General Industrial Use

A966/A966M Practice for Magnetic Particle Examination of Steel Forgings Using Alternating Current

A983/A983M Specification for Continuous Grain Flow Forged Carbon and Alloy Steel Crankshafts for Medium Speed Diesel Engines

A986/A986M Specification for Magnetic Particle Examination of Continuous Grain Flow Crankshaft Forgings

E1417/E1417M Practice for Liquid Penetrant Testing

3. Classification of Indications

3.1 Magnetic particle indications on the surface of the crankshaft shall be classified as follows:

3.1.1 Open cracks, flake, or pipe.

3.1.2 Nonmetallic inclusions or stringers occurring in a longitudinal direction.

3.1.3 Twist cracks or nonmetallic inclusions usually occurring at 45 to 70° from the axis of the journal.

3.2 They shall also be classified as follows:

3.2.1 Open indications are visible after removal of the magnetic particles or can be detected by the use of contrast dye penetrant, as described in Type II of Practice E1417/E1417M.

3.2.1.1 Pinpoint indications are open indications 1/16 in. [1.5 mm] in maximum dimension, as detected by application of Type II of Practice E1417/E1417M.

3.2.2 Non-open indications are indications which are not visually detectable as described in 3.2.1.

² For referenced ASTM standards, visit the ASTM website, www.astm.org, or contact ASTM Customer Service at service@astm.org. For *Annual Book of ASTM Standards* volume information, refer to the standard's Document Summary page on the ASTM website.

4. Ordering Information

4.1 The inquiry and purchase agreement shall contain a statement that the crankshaft(s) is (are) to be subject to acceptance according to this specification. If reference to class is omitted, Class 2 shall apply.

4.2 The use of Supplementary Requirements S1 and S2 should be specified if required.

5. Procedure

5.1 Magnetic particle inspection shall be conducted according to Practice A966/A966M, except when Supplementary Requirement S1 is to be used. The use of prod type contacts is not permitted on finished crankshafts. Magnetic leeches may only be used on noncritical parts of the crankshaft when Supplementary Requirement S2 is utilized.

6. Areas of Inspection

6.1 Major Critical Areas:

6.1.1 The critical area of any crankpin shall be that area plus or minus 60° from the 6 o'clock position of the pin extending 3/8 in. [10 mm] above the thrust collar around the fillet, and 5/8 in. [16 mm] into the pin along its axis measured from approximately the blend of the pin surface and fillet, as shown in Fig. 1 and Fig. 2.

6.1.2 The critical areas of any main bearing journal shall be that area plus or minus 60° from the 12 o'clock position on top of the journal extending 3/8 in. [10 mm] above the thrust collar around the fillet and 5/8 in. [16 mm] into the journal along its axis measured from approximately the blend of the journal surface and the fillet, as shown in Fig. 1 and Fig. 2.

6.1.3 The critical area of any crankpin or main journal also includes that surface area closer than 1/4 in. [6 mm] to the junction of the radius blend and the journal surface of any oil hole.

6.2 *Minor Critical Areas*—Minor critical areas include all machined fillets, thrust bearing, and bearing surfaces not specified as major critical areas.

7. Acceptance Standards

7.1 Class 1:

7.1.1 Major Critical Areas:

7.1.1.1 Open indications over 1/4 in. [6 mm] in length shall be removed by dimpling to a depth no greater than 3/16 in. [5 mm]. Open indications over 1/16 to 1/4 in. [1.5 to 6 mm] in length shall be depressed as in 7.2.2.3.

7.1.1.2 Pinpoint indications are permissible, except in clusters of more than 5 in any 1/4 by 1/4-in. [6 by 6-mm] area, in which case they must be dimpled to a depth of no more than 3/16 in. [5 mm]. If they do not open or increase in number they are acceptable and need not be removed.

7.1.1.3 Non-open indications are acceptable up to and including 1/2 in. [13 mm] in length. If non-open indications are over 1/2 in. [13 mm], depress, and if they are not open or are worsening, accept them. Otherwise remove by dimpling to a maximum depth of 3/16 in. [5 mm].

7.1.1.4 The total area of dimples shall be limited as in 7.2.1.3.

7.1.2 Minor Critical Areas:

7.1.2.1 Open indications oriented at an angle in excess of 30° to the longitudinal axis must be removed to a depth not exceeding 3/16 in. [5 mm], by dimpling.

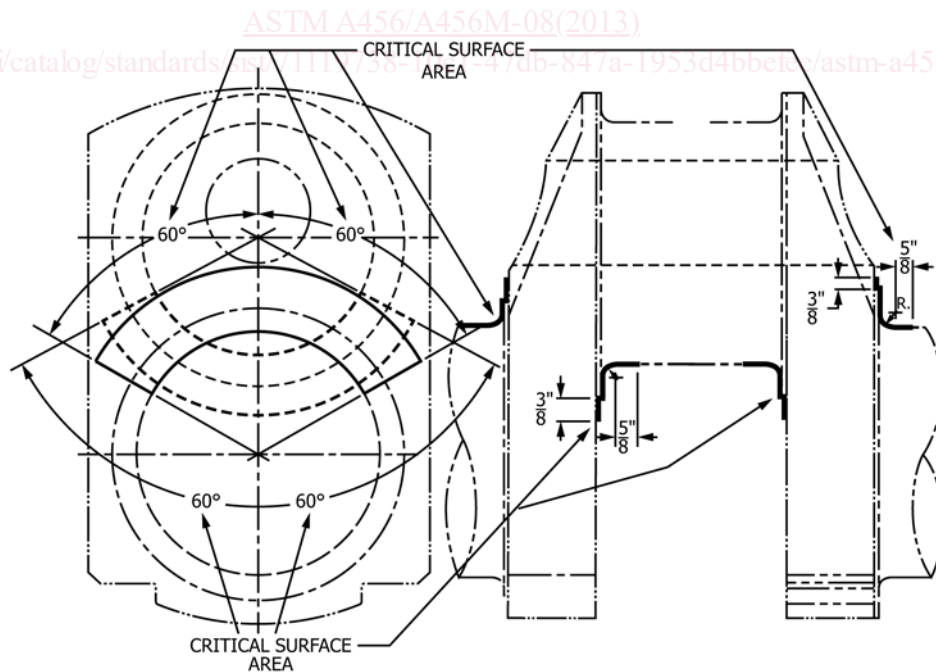

Metric Equivalents
 3/8 in. = [10 mm] 5/8 in. = [16 mm]

FIG. 1 Critical Surface Areas of Crankpin and Main Bearing Journal