



Designation: **D2844 – 07<sup>ε1</sup> D2844/D2844M – 13**

## Standard Test Method for Resistance *R*-Value and Expansion Pressure of Compacted Soils<sup>1</sup>

This standard is issued under the fixed designation **D2844/D2844M**; the number immediately following the designation indicates the year of original adoption or, in the case of revision, the year of last revision. A number in parentheses indicates the year of last reapproval. A superscript epsilon ( $\epsilon$ ) indicates an editorial change since the last revision or reapproval.

---

<sup>ε1</sup> NOTE—Added research report information to Section 12 editorially in September 2010.

---

### 1. Scope\*

1.1 This test method covers the procedure for testing both treated and untreated laboratory compacted soils or aggregates with the stabilometer and expansion pressure devices to obtain results indicative of performance when placed in the base, subbase, or subgrade of a road subjected to traffic.

1.2 *Units*—The values stated in either SI units or inch-pound units [presented in brackets] are to be regarded as the separately as standard. The values stated in each system may not be exact equivalents; therefore, each system shall be used independently of the other. Combining values from the two systems may result in non-conformance with the standard. However, use of equipment manufactured to be readable in inch-pound units only should not be considered as non-conformance to the test method. Many stabilometers and expansion pressure devices are manufactured to be readable in inch-pound units only.

1.3 All observed and calculated values shall conform to the guidelines for significant digits and rounding established in Practice **D6026**.

1.3.1 For purposes of comparing measured or calculated value(s) with specified limits, the measured or calculated value(s) shall be rounded to the nearest decimal or significant digits in the specified limits.

1.3.2 The procedures used to specify how data are collected/recorded or calculated, in this standard are regarded as the industry standard. In addition, they are representative of the significant digits that generally should be retained. The procedures used do not consider material variation, purpose for obtaining the data, special purpose studies, or any considerations for the user's objectives; and it is common practice to increase or reduce significant digits of reported data to be commensurate with these considerations. It is beyond the scope of this standard to consider significant digits used in analytical methods for engineering design.

1.4 *This standard does not purport to address all of the safety concerns, if any, associated with its use. It is the responsibility of the user of this standard to establish appropriate safety and health practices and determine the applicability of regulatory limitations prior to use.*

### 2. Referenced Documents

#### 2.1 ASTM Standards:<sup>2</sup>

**C670** Practice for Preparing Precision and Bias Statements for Test Methods for Construction Materials

**D653** Terminology Relating to Soil, Rock, and Contained Fluids

**D3740** Practice for Minimum Requirements for Agencies Engaged in Testing and/or Inspection of Soil and Rock as Used in Engineering Design and Construction

**D6026** Practice for Using Significant Digits in Geotechnical Data

**E4** Practices for Force Verification of Testing Machines

**E11** Specification for Woven Wire Test Sieve Cloth and Test Sieves

#### 2.2 AASHTO Documents:

**T 190** Test Method for Resistance *R*-Value and Expansion Pressure of Compacted Soils<sup>3</sup>

<sup>1</sup> This test method is under the jurisdiction of ASTM Committee **D18** on Soil and Rock and is the direct responsibility of Subcommittee **D18.08** on Special and Construction Control Tests.

Current edition approved Feb. 1, 2007; Jan. 1, 2013. Published March 2007; February 2013. Originally approved in 1969. Last previous edition approved in 2004 as **D2844 – 04**<sup>07</sup><sup>ε1</sup>. DOI: 10.1520/D2844-07E01-10.1520/D2844\_D2844M-13.

<sup>2</sup> For referenced ASTM standards, visit the ASTM website, [www.astm.org](http://www.astm.org), or contact ASTM Customer Service at [service@astm.org](mailto:service@astm.org). For *Annual Book of ASTM Standards* volume information, refer to the standard's Document Summary page on the ASTM website.

<sup>3</sup> Available from American Association of State Highway and Transportation Officials (AASHTO), 444 N. Capitol St., NW, Suite 249, Washington, DC 20001, <http://www.transportation.org>.

\*A Summary of Changes section appears at the end of this standard

2.3 ASTM Adjuncts:<sup>4</sup>

- Exudation Device
- Expansion Pressure Apparatus
- Stabilometer

2.4 CALTRANS Standard:<sup>5</sup>

California Test 103 Method of Test For Calibration of Expansion Pressure Devices

3. Terminology

3.1 For definitions of terms in this test method, refer to Terminology D653.

4. Significance and Use

4.1 This test method is used to measure the potential strength of subgrade, subbase, and base course materials for use in road and airfield pavements. The R-value is used by some agencies as criteria for acceptance of aggregates for base course and bituminous courses.

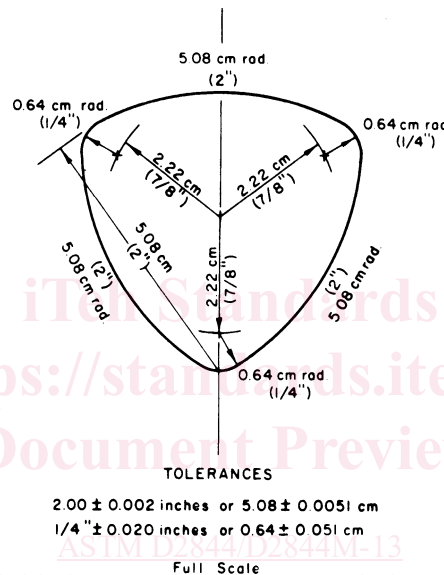

FIG. 1 Tamper Shoe for Kneading Compactor

4.2 The expansion pressure testing has been used in conjunction with the R-value test to determine cover requirements (thickness) and construction controls to reduce pavement distortion from expansive subgrade soils.

NOTE 1—The quality of the result produced by this standard is dependent on the competence of the personnel performing it, and the suitability of the equipment and facilities used. Agencies that meet the criteria of Practice D3740 are generally considered capable of competent and objective testing/sampling/inspection/etc. Users of this test method are cautioned that compliance with Practice D3740 does not in itself ensure reliable results. Reliable results depend on many factors; Practice D3740 provides a means of evaluating some of those factors.

5. Apparatus

NOTE 2—The inch-pound dimensions [presented in brackets], found in this section are for equipment commonly available in the United States.

5.1 *Kneading Compactor*, capable of applying an average contact pressure of  $2410 \pm 110$  kPa ( $350[350 \pm 16$  psi] psi) to the tamper foot shown in Fig. 1 and with provisions for maintaining this pressure during changes in sample height. The load-time trace shall be free of “chatter” or evidence of impact-associated changes in slope. The rise time for application of foot pressure, in the range from 240 to 2070 kPa ( $35[35$  to  $300$  psi] psi), shall not be less than 0.07 nor more than 0.20 s: 0.07 to 0.20 seconds. The dwell time, measured at 300 psi-2070 kPa [300 psi] foot pressure, shall not be less than 0.15 nor more than 0.45 s: 0.15 to 0.45 seconds. The pressure-release or removal time shall not be greater than 0.60 s: seconds.

5.1.1 The compactor shall include a counter or timer for measuring the number of tamps applied to a specimen and a mold holder, for use in compacting specimens, that rotates equally between tamps to give 5 to 7 tamps per revolution of the mold. The holder shall firmly restrain the mold during compaction. The base of the mold holder shall have a metal plate  $100.8$  ( $3$ - $100.8$  mm

<sup>4</sup> Copies of detailed drawings of the apparatus shown in Figs. 4 (1 drawing), 67 (4 drawings), 710 and 811 (7 drawings) are available at a nominal cost from ASTM International Headquarters. Request Adjunct Nos. ADJD284401, ADJD284402, and ADJD284403, respectively.

<sup>5</sup> Available from State of California Department of Transportation (CALTRANS), P.O. Box 942873, Sacramento, CA 94273-0001, <http://www.dot.ca.gov>. Proving Lever Assembly detailed drawings are available here as well.

[3 3/32 in.] in mm) in diameter and 12.7 mm (0.5 in.) high [0.5 in.] in height, to which is cemented a rubber disk having a diameter of 100.0 mm (3 15/16 in.) in. and a height thickness of 3.2 mm. (mm [1/8 in.] in.). The plate shall be an integral part of the base of the mold holder. The compactor shall also include a trough for feeding the sample into the mold in 20 increments (Fig. 2). Troughs with a semicircular cross section of 39 cm<sup>2</sup> (6 [6.0 in.]<sup>2</sup>) in area and 50.8 cm (20 in.) long [20 in.] in length have proven satisfactory.

5.2 *Compression Testing Machine*, with a minimum capacity of 45 kN (10 000 lbf) kN [10 000 lbf] and satisfying the requirements of Practices E4.

5.3 *Mold*, 101.6 ± 0.05 mm (4 [4.0 ± 0.002 in.] in.) inside diameter by 127 ± 0.20 mm (5 [5.0 ± 0.008 in.] in.) high. (See Fig. 3 for surface roughness.)

5.4 *Rubber Disks*, 100 mm (3 [3 15/16 in.] in.) in diameter by 3 mm (1/8 in.) in. thick and having a durometer hardness of 60 ± 15.

5.5 *Metal Follower*, solid-walled, metal specimen follower 100.33 ± 0.13 mm (3.95 [3.95 ± 0.005 in.] in.) in outside diameter by 127 mm (5 in.) [5.0 in.] long.

5.6 *Exudation Indicator Device*, as shown in Fig. 4<sup>4</sup> and Fig. 5.

5.7 *Phosphor Bronze Disk*, as shown in Fig. 56.

5.8 *Filter Paper*, 100 mm [4.0 in.] in diameter and 150.15 mm (0.006 in.) thick, [0.006 in.] thick, with a smooth surface, medium filtering speed, medium retention.

5.9 *Filter Paper*, 110 mm [4.3 in.] in diameter and 150.15 mm (0.006 in.) thick, [0.006 in.] thick, with a creped surface, medium-fast filtering speed, and medium retention.

5.10 *Expansion-Pressure Device*, with accessories as shown in Fig. 67.<sup>4</sup> There should be at least three of these devices for each sample to be tested within a day's time.



FIG. 2 Compactor with Sample Feed Trough

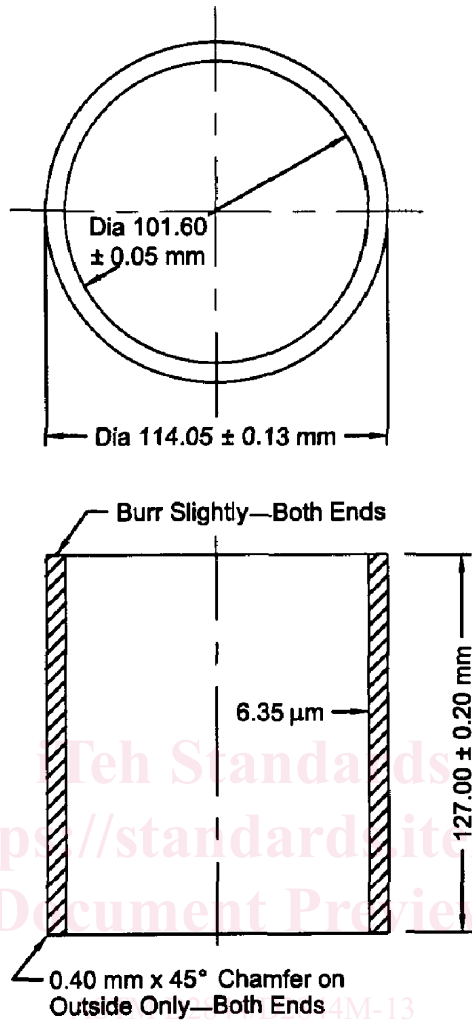

FIG. 3 Mold

NOTE 1—Inside roughness is obtained by smooth machining inside to required diameter of 101.6 ± 0.05 mm (4.000 [4.000 ± 0.002 in.] in.) followed on final operation with a boring tool bit ground to a 90° point with sharp point ground flat measuring 0.025 to 0.075 mm (0.001 [0.001 to 0.003 in.] in.) across. Depth of cut is 0.050 mm (0.002 in.) with 0.25 mm (0.010 in.) feed using sulfur-based oil coolant.

- 5.11 Deflection Gage, with divisions of 0.002 mm (0.0001 in.) [0.0001 in.] and an allen wrench as shown in Fig. 67.
- 5.12 Proving Lever Assembly, as shown in Fig. 8 and Fig. 9.<sup>5</sup>
- 5.13 Stabilometer, with accessories, as shown in Fig. 710 and Fig. 811.<sup>4</sup>
- 5.14 Standard Metal Specimen, 101.60 mm (4 in.) 101.6 mm [4.0 in.] in outside diameter by 152.2 mm (6 in.) [6.0 in.] high as shown in Fig. 811.
- 5.15 Balance, 5000-g capacity, accurate and readable to 1 g.
- 5.16 Sieves, 25.0 mm (1 in.) [1 in.], 19.0 mm (3/4 in.) [3/4 in.] and 4.75 mm (No. 4) [No. 4] conforming to the requirements of Specification E11.
- 5.17 Miscellaneous Equipment, including mixing pans, spoons, spatulas, and gallon cans with close-fitting lids.

## 6. Soil Preparation

- 6.1 Remove any coatings from coarse aggregate and break clay lumps to pass the 4.75-mm (No. 4) [No. 4] sieve.
- 6.2 Adjust the soil gradation when some of the gradation when material is retained on the 19.0-mm (3/4 in.) [3/4 in.] sieve. When 75% or more passes the 19.0-mm (19.0-mm [3/4 in.] in.) sieve, use that part of the sample passing the 19.0-mm (19.0-mm [3/4 in.] in.) sieve. If less than 75% of the sample passes the 1-in. sieve 25.0-mm [1-in.] sieve, use that part of the sample passing the 25.0-mm (1-in.) sieve. See Table 1 for a sample calculation.



FIG. 4 Circular Exudation-Indicator Device

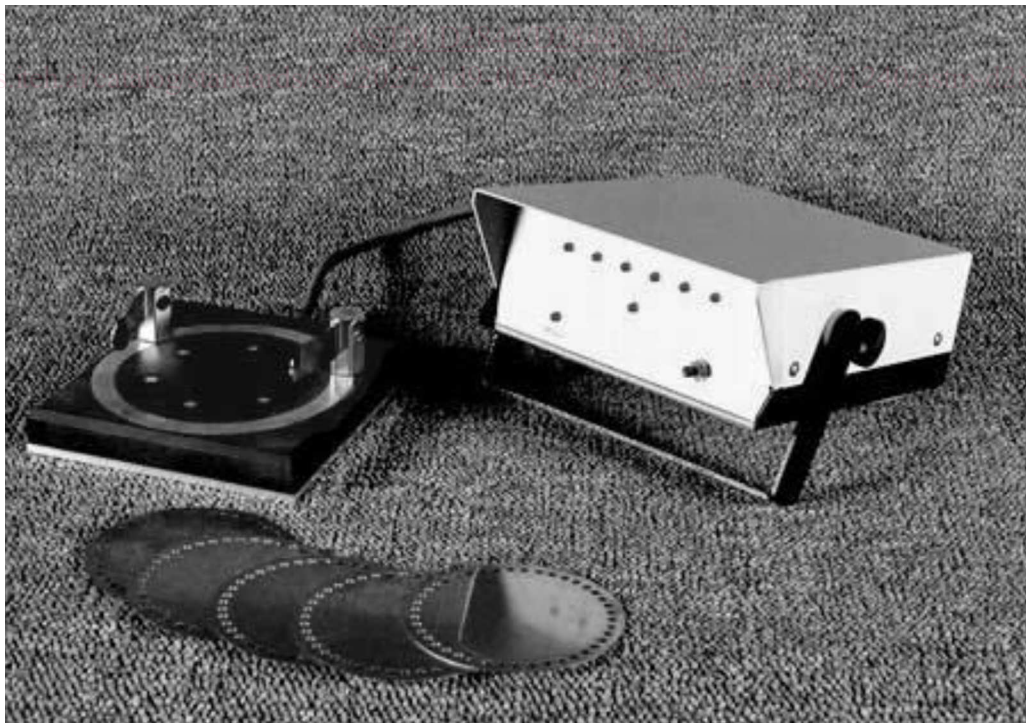

FIG. 5 Linear Exudation-Indicator Device

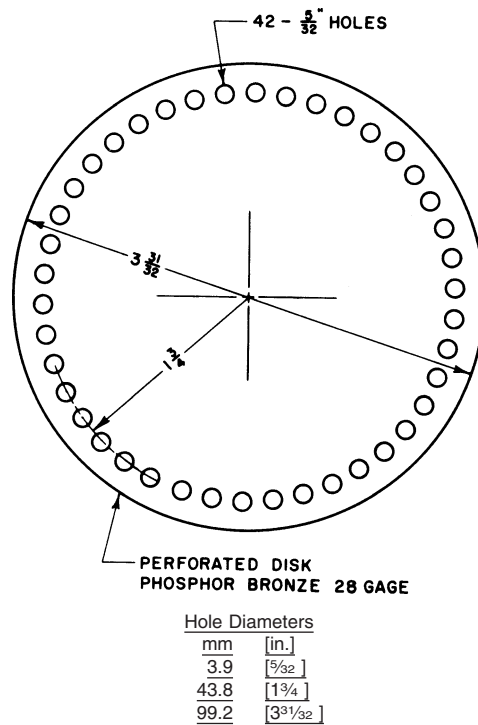

FIG. 56 Phosphor-Bronze Disk

## 7. Preparation of Soil Specimens

7.1 Thoroughly mix four approximately 1200-g [2.7-lb] samples of soil with the amount of water estimated to equal one half to two thirds of the water required to produce saturation as defined in 7.3 and 7.4. Place the samples in covered containers and allow them to stand overnight. Just prior to compaction, mix the samples with the final amount of water required to produce saturation. The first sample is used as a pilot specimen to assist in determining the final amount of water required.

7.2 Weigh out enough material to fabricate a compacted sample 101.6 mm (4 in.) [4.0 in.] in diameter by 63 mm (2.5 in.) [2.5 in.] high. Compacted specimens having heights from 62 to 65 mm (2.45 [2.45 to 2.55 in.] in.) are acceptable. Compact the soil into the mold by means of the kneading compactor as follows: Place the mold ~~in the mold holder which has a rubber disk, 100 mm (3 over the mold holder, 1 5/16 in.) in diameter and 3 mm (1/8 in.) thick, cemented to the plate.~~ Adjust the mold for approximately 3-mm (1/8 in.) in. clearance between the lower edge of the mold and base of the mold holder. A metal angle bracket of 3-mm [1/8 in.] thickness and approximately 37.5 mm [1 1/2 in.] length placed on the base of the mold holder have proven satisfactory. Alternately, tighten the set screw, if available, on the mold holder. Spread the sample along the length of the trough. With the compactor-foot pressure set at 1720 ± 170 kPa (250 [250 ± 25 psi]; psi), feed 7675 mm (3 in.) [3.0 in.] of the soil from the trough into the mold. Redistribute the sample remaining in trough as needed to feed the balance of the soil into the mold in 20 equal increments with one application of the ram after each increment. Allow 10 additional tamps to level the soil, then place a rubber disk on top of the specimen. Remove the shim from under the mold or loosen the set screw. Apply 100 additional tamps with a foot pressure of 2410 kPa (350 psi) [350 psi]. Stop compacting the soil at any time before 100 tamps if water appears around the bottom of the mold.

NOTE 3—Use lower compaction pressures when necessary to limit penetration of the ram into the soil to not greater than 6 mm (1/4 in.) in.).

7.3 Remove the mold containing the compacted specimen from the compactor. Level the tamped surface by hand tamping with a 38-mm (1.5 in.) [1.5 in.] diameter rod. Place a phosphor-bronze disk on the tamped surface of the soil and place a 100-mm filter paper on top of the bronze disk. Invert the mold and place it on the exudation device so that the filter paper is on the bottom. Place the solid walled, metal specimen follower into the mold. Using the compression testing machine, apply a uniformly increasing pressure to the soil at the rate of 8900 N (2000-N [2000 lbf ]/min.;/min. Water should be exuded from the soil at 2070 kPa (300 psi) [300 psi] as evidence that enough moisture is present to produce saturation. Stop the loading and record the exudation pressure to the nearest 10 kPa (1 psi) [1 psi] when either five of the six outer indicator lights on the exudation pressure indicator device are lighted or three outer indicator lights are lighted and free water is visible around the bottom of the mold. Do not exceed a exudation pressure of 5520 kPa (800 psi) [800 psi].

7.4 Mold at least two more specimens with different amounts of moisture so that a range of exudation pressures from 690 to 5520 kPa (100 [100 to 800 psi) (psi) Note 3) is obtained ~~which brackets bracketing~~ the 2070 kPa (300 psi) [300 psi] value. For some