**Belt drives — Pulleys for V-belts
(system based on datum width) —
Geometrical inspection of grooves**

*Transmissions par courroies — Poulies à gorges pour courroies
trapézoïdales (système basé sur la largeur de référence) — Contrôle
géométrique des gorges*

iTeh STANDARD PREVIEW
(standards.iteh.ai)

ISO 255:2023

<https://standards.iteh.ai/catalog/standards/sist/d91893d9-5c45-47cc-9013-2d93127a0f38/iso-255-2023>



iTeh STANDARD PREVIEW (standards.iteh.ai)

ISO 255:2023

<https://standards.iteh.ai/catalog/standards/sist/d91893d9-5c45-47cc-9013-2d93127a0f38/iso-255-2023>



COPYRIGHT PROTECTED DOCUMENT

© ISO 2023

All rights reserved. Unless otherwise specified, or required in the context of its implementation, no part of this publication may be reproduced or utilized otherwise in any form or by any means, electronic or mechanical, including photocopying, or posting on the internet or an intranet, without prior written permission. Permission can be requested from either ISO at the address below or ISO's member body in the country of the requester.

ISO copyright office
CP 401 • Ch. de Blandonnet 8
CH-1214 Vernier, Geneva
Phone: +41 22 749 01 11
Email: copyright@iso.org
Website: www.iso.org

Published in Switzerland

Contents

Page

Foreword.....	iv
Introduction.....	v
1 Scope.....	1
2 Normative references.....	1
3 Terms and definitions.....	1
4 Symbols.....	1
5 Principle.....	2
6 Groove profile.....	2
6.1 Specification.....	2
6.2 Inspection.....	2
6.2.1 Limit gauges.....	2
6.2.2 Operation.....	3
7 Groove spacing.....	7
7.1 Specification.....	7
7.1.1 Groove spacings.....	7
7.1.2 Distance between edge of pulley and first group centre.....	8
7.2 Inspection.....	8
8 Datum diameter.....	9
8.1 Specifications.....	9
8.1.1 Datum diameter.....	9
8.1.2 Checking balls or rods.....	9
8.2 Inspection.....	9
9 Run-out tolerances.....	10
9.1 Specifications.....	10
9.2 Inspection.....	10
Annex A (normative) Groove inspection with balls or rods for pulleys used with classical and narrow V-belts as defined by ISO 4183.....	11
Bibliography.....	12

Foreword

ISO (the International Organization for Standardization) is a worldwide federation of national standards bodies (ISO member bodies). The work of preparing International Standards is normally carried out through ISO technical committees. Each member body interested in a subject for which a technical committee has been established has the right to be represented on that committee. International organizations, governmental and non-governmental, in liaison with ISO, also take part in the work. ISO collaborates closely with the International Electrotechnical Commission (IEC) on all matters of electrotechnical standardization.

The procedures used to develop this document and those intended for its further maintenance are described in the ISO/IEC Directives, Part 1. In particular, the different approval criteria needed for the different types of ISO documents should be noted. This document was drafted in accordance with the editorial rules of the ISO/IEC Directives, Part 2 (see www.iso.org/directives).

Attention is drawn to the possibility that some of the elements of this document may be the subject of patent rights. ISO shall not be held responsible for identifying any or all such patent rights. Details of any patent rights identified during the development of the document will be in the Introduction and/or on the ISO list of patent declarations received (see www.iso.org/patents).

Any trade name used in this document is information given for the convenience of users and does not constitute an endorsement.

For an explanation of the voluntary nature of standards, the meaning of ISO specific terms and expressions related to conformity assessment, as well as information about ISO's adherence to the World Trade Organization (WTO) principles in the Technical Barriers to Trade (TBT), see www.iso.org/iso/foreword.html.

This document was prepared by Technical Committee ISO/TC 41, *Pulleys and belts (including veebelts)*, Subcommittee SC 1, *Friction*.

This third edition cancels and replaces the second edition (ISO 255:1990), which has been technically revised.

The main changes are as follows:

- the normative references list has been updated, including adding of ISO 1081 (vocabulary);
- in [Clause 2](#) and Bibliography, normative references are no longer dated;
- modifications made for clarification and to be in line with ISO drafting rules.

Any feedback or questions on this document should be directed to the user's national standards body. A complete listing of these bodies can be found at www.iso.org/members.html.

Introduction

In drives using V-belts, the dimensions of the pulley grooves can be defined either on the basis of the datum width or on the basis of the effective width. As a result, two systems for definition and description of the dimensions of pulleys and belts have been developed. The two systems are independent of each other.

For the geometrical inspection of grooves defined on the basis of the datum width, necessary tests to ensure by mechanical means the conformity of a grooved pulley with standard specifications were specified, but modern quick or serial checking procedures for grooved pulley production control were not.

For user clarification, the interaction of this document with other relevant documents developed by ISO/TC 41/SC 1 and ISO/TC 213 “Dimensional and geometrical product specifications and verification” is given in [Figure 1](#).

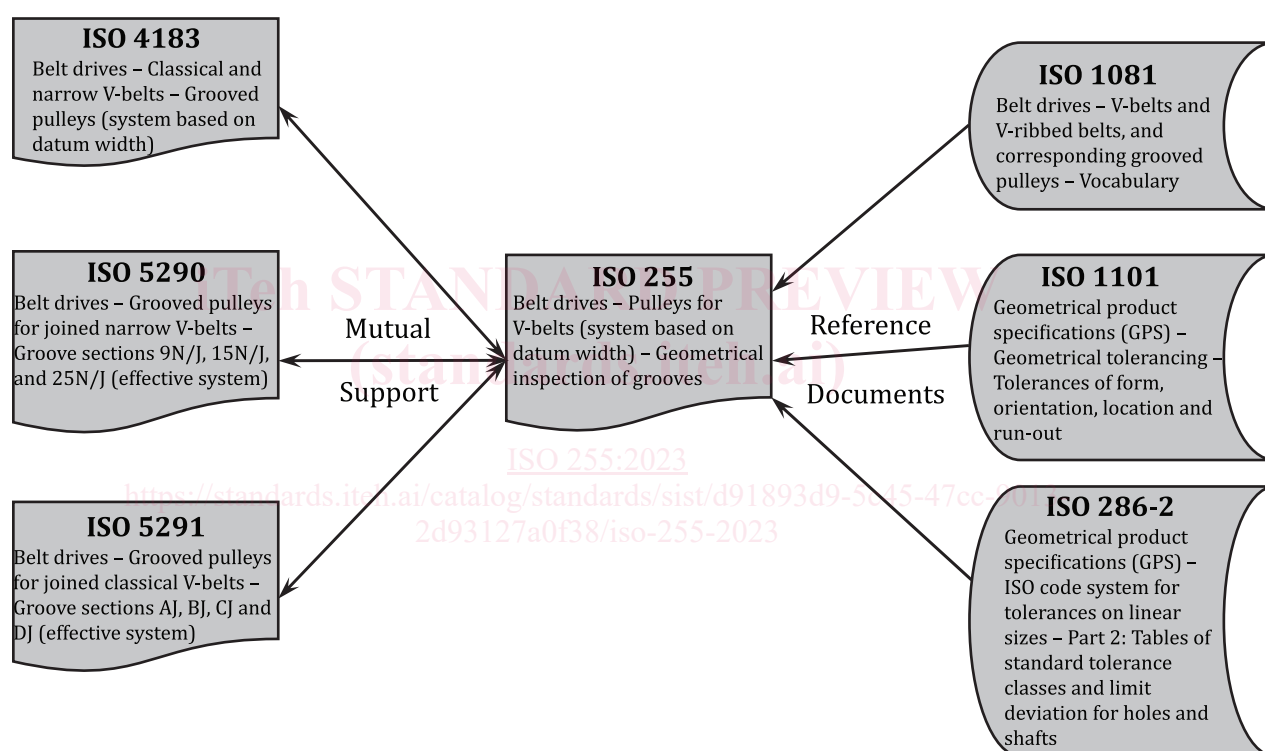

Figure 1 — Interaction of this document with other relevant documents developed by ISO/TC 41/SC 1 and ISO/TC 213

Belt drives — Pulleys for V-belts (system based on datum width) — Geometrical inspection of grooves

1 Scope

This document specifies the methods of checking the regularity of the grooves and pulleys for V-belts specified in the system based on datum width. The grooved pulleys may be designed for use with classical or narrow V-belts.

Inspection parameters and tolerances of grooved pulleys are covered by appropriate International Standards.

2 Normative references

The following documents are referred to in the text in such a way that some or all of their content constitutes requirements of this document. For dated references, only the edition cited applies. For undated references, the latest edition of the referenced document (including any amendments) applies.

ISO 1081, *Belt drives — V-belts and V-ribbed belts, and corresponding grooved pulleys — Vocabulary*

3 Terms and definitions

For the purposes of this document, the terms and definitions given in ISO 1081 apply.

ISO and IEC maintain terminology databases for use in standardization at the following addresses:

- ISO Online browsing platform: available at <https://www.iso.org/obp>
- IEC Electropedia: available at <https://www.electropedia.org/>

4 Symbols

For the purpose of this document, the symbols given in ISO 1081 and the following apply.

Symbol	Definition
b	Groove height above datum width
d	Diameter of balls or rods
d_d	Datum diameter - nominal value
d_o	Outside diameter - nominal value
e	Distance between the axes of two consecutive grooves - nominal value
f	Distance between the outside of the rim and the axis of the first groove for all single- and multiple-groove pulleys
h	Groove depth below datum width
h_s	Corrective term
K	Distance between the planes that are externally tangent to the balls or rods and parallel to the axis of the pulley
t_1	Radial circular run-out tolerance of the outside diameter
t_2	Axial circular run-out tolerance measured perpendicular to the groove sidewall at the datum diameter
w_d	Datum width

Symbol	Definition
x	Measured dimension
α	Groove angle

5 Principle

Complete inspection of a grooved pulley carried out in four successive checking operations, in the following order:

- inspection of groove profile (see [Clause 6](#));
- inspection of groove spacing (see [Clause 7](#));
- inspection of datum diameter (see [Clause 8](#));
- inspection of run-out (see [Clause 9](#)).

6 Groove profile

6.1 Specification

The groove profile dimensions (see dimensions shown in [Figure 2](#) and summarized in [Table 1](#)) are given in ISO 4183.

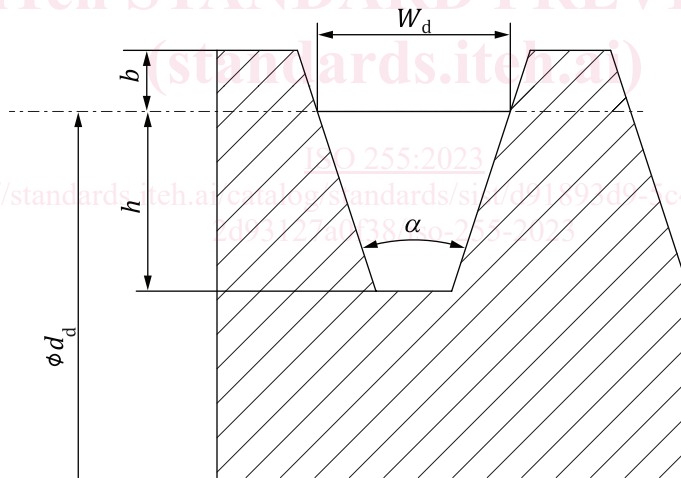

Figure 2 — Groove profile

Table 1 — Groove profile specification

Dimension	Symbol	Tolerance
Datum width	w_d	Specified value not subject to tolerance
Groove angle	α	$\pm\Delta\alpha$
Groove height above datum width	b	Minimum value
Groove depth below datum width	h	Minimum value

6.2 Inspection

6.2.1 Limit gauges

The groove profile shall be checked using a limit gauge shown diagrammatically in [Figure 3](#).

A gauge for each of the standard angles applicable to each groove section, as specified in ISO 4183, is required.

The limit gauges shall be marked with the groove section and the groove angle.

6.2.2 Operation

The limit gauge is shown in [Figure 3](#).

The “min” end of the limit gauge is used to check the minimum value of the groove angle. The gauge shall contact the groove at the lower corners (see [Figure 4](#)) or uniformly along the sidewalls.

The “max” end of the limit gauge is used to check the maximum value of the groove angle, the datum width, the groove height, b , and the groove depth, h , in the same operation.

The groove angle, the datum width, the groove height, b , and the groove depth, h , conform with the specifications if the corners of the gauge at width w_d contact the sidewalls of the groove and if the horizontal steps of the gauge are situated within the straight sidewalls of the groove (see [Figure 5](#)).

The groove angle is too great if only the lower corners of the “max” end of the gauge contact the groove.

The datum width is too small or the groove height, b , too low if the horizontal steps of the gauge are situated above the straight sidewalls of the groove (see [Figure 6](#)).

The groove depth, h , is too low if the gauge touches the bottom of the groove and the corners of the gauge at width w_d do not contact the sidewalls of the groove (see [Figure 7](#)).

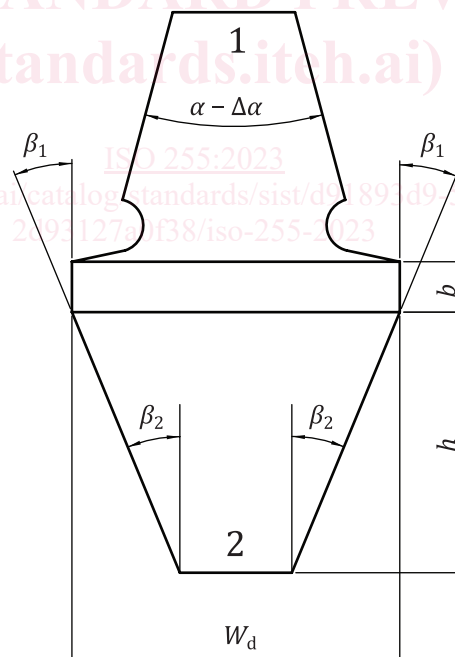

Key

1 min

2 max

β_1 and β_2 are defined by the following formulae:

$$\beta_1 = \frac{\alpha - \Delta\alpha}{2}$$

$$\beta_2 = \frac{\alpha + \Delta\alpha}{2}$$

Figure 3 — Limit gauge

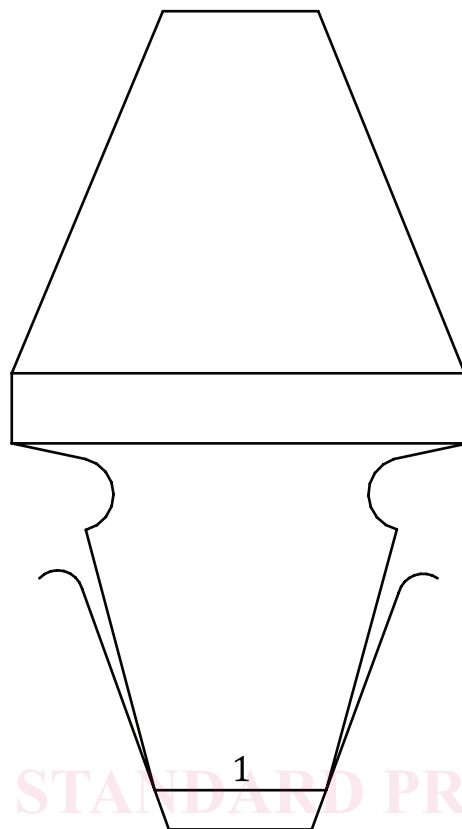

Key
1 min

ISO 255:2023
Figure 4 — Fitting of limit gauge in the groove to be checked
<https://standards.iteh.ai/catalog/standards/sist/d51895d9-9c49-47cc-9013-2d93127a0f38/iso-255-2023>

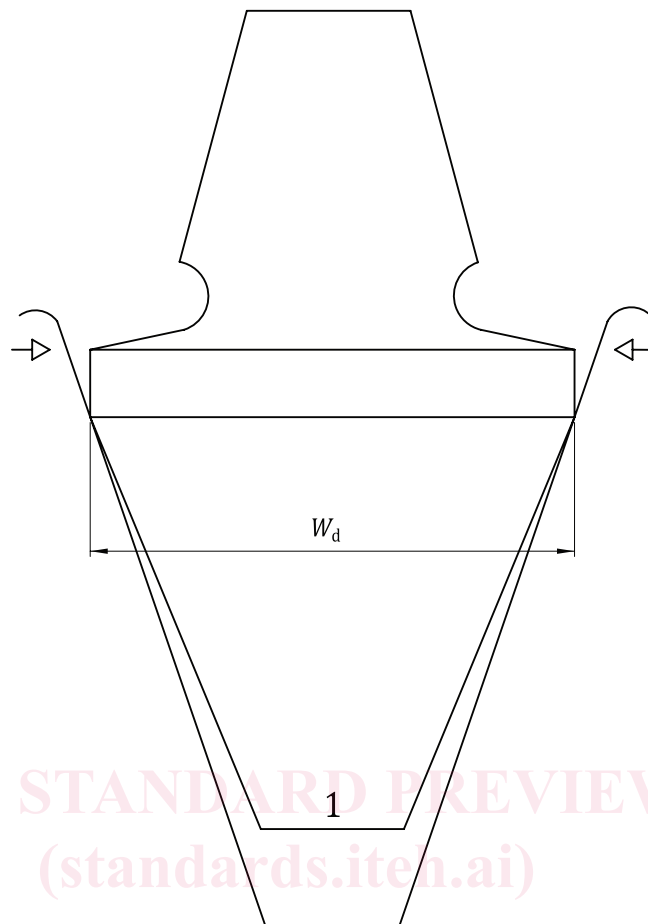
**Key**

- 1 max <https://standards.itih.ai/catalog/standards/sist/d91893d9-5c45-47cc-9013-2d93127a0f38/iso-255-2023>

Figure 5 — Inspection of groove profile (good)