



Designation: ~~C1359—11~~ C1359 – 13

Standard Test Method for Monotonic Tensile Strength Testing of Continuous Fiber- Reinforced Advanced Ceramics With Solid Rectangular Cross-Section Test Specimens at Elevated Temperatures¹

This standard is issued under the fixed designation C1359; the number immediately following the designation indicates the year of original adoption or, in the case of revision, the year of last revision. A number in parentheses indicates the year of last reapproval. A superscript epsilon (ϵ) indicates an editorial change since the last revision or reapproval.

1. Scope*

1.1 This test method covers the determination of tensile strength including stress-strain behavior under monotonic uniaxial loading of continuous fiber-reinforced advanced ceramics at elevated temperatures. This test method addresses, but is not restricted to, various suggested test specimen geometries as listed in the appendix. In addition, test specimen fabrication methods, testing modes (force, displacement, or strain control), testing rates (force rate, stress rate, displacement rate, or strain rate), allowable bending, temperature control, temperature gradients, and data collection and reporting procedures are addressed. Tensile strength as used in this test method refers to the tensile strength obtained under monotonic uniaxial loading where monotonic refers to a continuous nonstop test rate with no reversals from test initiation to final fracture.

1.2 This test method applies primarily to advanced ceramic matrix composites with continuous fiber reinforcement: uni-directional (1-D), bi-directional (2-D), and tri-directional (3-D) or other multi-directional reinforcements. In addition, this test method may also be used with glass (amorphous) matrix composites with 1-D, 2-D, 3-D and other multi-directional continuous fiber reinforcements. This test method does not directly address discontinuous fiber-reinforced, whisker-reinforced, or particulate-reinforced ceramics, although the test methods detailed here may be equally applicable to these composites.

1.3 The values stated in SI units are to be regarded as the standard and are in accordance with .

1.4 *This standard does not purport to address all of the safety concerns, if any, associated with its use. It is the responsibility of the user of this standard to establish appropriate safety and health practices and determine the applicability of regulatory limitations prior to use.* Refer to Section 7 for specific precautions.

2. Referenced Documents

2.1 *ASTM Standards:*²

[C1145 Terminology of Advanced Ceramics](#)

[D3878 Terminology for Composite Materials](#)

[D6856/D6856M Guide for Testing Fabric-Reinforced “Textile” Composite Materials](#)

[E4 Practices for Force Verification of Testing Machines](#)

[E6 Terminology Relating to Methods of Mechanical Testing](#)

[E21 Test Methods for Elevated Temperature Tension Tests of Metallic Materials](#)

[E83 Practice for Verification and Classification of Extensometer Systems](#)

[E220 Test Method for Calibration of Thermocouples By Comparison Techniques](#)

[E337 Test Method for Measuring Humidity with a Psychrometer \(the Measurement of Wet- and Dry-Bulb Temperatures\)](#)

[E1012 Practice for Verification of Testing Frame and Specimen Alignment Under Tensile and Compressive Axial Force Application](#)

[SI10-02 IEEE/ASTM SI 10 American National Standard for Use of the International System of Units \(SI\): The Modern Metric System](#)

¹ This test method is under the jurisdiction of ASTM Committee C28 on Advanced Ceramics and is the direct responsibility of Subcommittee C28.07 on Ceramic Matrix Composites.

Current edition approved July 15, 2011; Feb. 15, 2013. Published August 2011; April 2013. Originally approved in 1996. Last previous edition approved in 2005 as ~~C1359—05~~ C1359 – 11. DOI: [10.1520/C1359-11](#); [10.1520/C1359-13](#).

² For referenced ASTM standards, visit the ASTM website, [www.astm.org](#), or contact ASTM Customer Service at [service@astm.org](#). For *Annual Book of ASTM Standards* volume information, refer to the standard’s Document Summary page on the ASTM website.

*A Summary of Changes section appears at the end of this standard

3. Terminology

3.1 Definitions:

3.1.1 Definitions of terms relating to tensile testing, advanced ceramics, fiber-reinforced composites as they appear in Terminology E6, Terminology C1145, and Terminology D3878, respectively, apply to the terms used in this test method. Pertinent definitions are shown in the following with the appropriate source given in parentheses. Additional terms used in conjunction with this test method are defined in 3.2.

3.2 Definitions of Terms Specific to This Standard:

3.2.1 *advanced ceramic, n*—highly engineered, high-performance predominately nonmetallic, inorganic, ceramic material having specific functional attributes. **C1145**

3.2.2 *axial strain $[LL^{-1}]$, n*—average longitudinal strains measured at the surface on opposite sides of the longitudinal axis of symmetry of the specimen by two strain-sensing devices located at the mid length of the reduced section. **E1012**

3.2.3 *bending strain $[LL^{-1}]$, n*—difference between the strain at the surface and the axial strain. In general, the bending strain varies from point to point around and along the reduced section of the specimen. **E1012**

3.2.4 *breaking force $[F]$, n*—force at which fracture occurs. **E6**

3.2.5 *ceramic matrix composite, n*—material consisting of two or more materials (insoluble in one another), in which the major, continuous component (matrix component) is a ceramic, while the secondary component(s) (reinforcing component) may be ceramic, glass-ceramic, glass, metal, or organic in nature. These components are combined on a macroscale to form a useful engineering material possessing certain properties or behavior not possessed by the individual constituents.

3.2.6 *continuous fiber-reinforced ceramic matrix composite (CFCC), n*—ceramic matrix composite in which the reinforcing phase consists of a continuous fiber, continuous yarn, or a woven fabric.

3.2.7 *fracture strength $[FL^{-2}]$, n*—tensile stress that the material sustains at the instant of fracture. Fracture strength is calculated from the force at fracture during a tension test carried to rupture and the original cross-sectional area of the specimen. **E6**

3.2.7.1 Discussion—

In some cases, the fracture strength may be identical to the tensile strength if the force at fracture is the maximum for the test.

3.2.8 *gage length $[L]$, n*—original length of that portion of the specimen over which strain or change of length is determined. **E6**

3.2.9 *matrix-cracking stress $[FL^{-2}]$, n*—applied tensile stress at which the matrix cracks into a series of roughly parallel blocks normal to the tensile stress.

3.2.9.1 Discussion—

In some cases, the matrix cracking stress may be indicated on the stress-strain curve by deviation from linearity (proportional limit) or incremental drops in the stress with increasing strain. In other cases, especially with materials which do not possess a linear portion of the stress-strain curve, the matrix cracking stress may be indicated as the first stress at which a permanent offset strain is detected in the unloading stress-strain (elastic limit) curve.

3.2.10 *modulus of elasticity $[FL^{-2}]$, n*—ratio of stress to corresponding strain below the proportional limit. **E6**

3.2.11 *modulus of resilience $[FLL^{-3}]$, n*—strain energy per unit volume required to elastically stress the material from zero to the proportional limit indicating the ability of the material to absorb energy when deformed elastically and return it when unloaded.

3.2.12 *modulus of toughness $[FLL^{-3}]$, n*—strain energy per unit volume required to stress the material from zero to final fracture indicating the ability of the material to absorb energy beyond the elastic range (that is, damage tolerance of the material).

3.2.12.1 Discussion—

The modulus of toughness can also be referred to as the cumulative damage energy and as such is regarded as an indication of the ability of the material to sustain damage rather than as a material property. Fracture mechanics methods for the characterization of CFCCs have not been developed. The determination of the modulus of toughness as provided in this test method for the characterization of the cumulative damage process in CFCCs may become obsolete when fracture mechanics methods for CFCCs become available.

3.2.13 *proportional limit stress $[FL^{-2}]$, n*—greatest stress which a material is capable of sustaining without any deviation from proportionality of stress to strain (Hooke's law). **E6**

3.2.13.1 Discussion—

Many experiments have shown that values observed for the proportional limit vary greatly with the sensitivity and accuracy of the testing equipment, eccentricity of loading, the scale to which the stress-strain diagram is plotted, and other factors. When determination of proportional limit is required, the procedure and sensitivity of the test equipment shall be specified.

3.2.14 *percent bending*, n —bending strain times 100 divided by the axial strain. **E1012**

3.2.15 *slow crack growth (SCG)*, n —subcritical crack growth (extension) which may result from, but is not restricted to, such mechanisms as environmentally-assisted stress corrosion or diffusive crack growth. **C1145**

3.2.16 *tensile strength* [FL^{-2}], n —maximum tensile stress which a material is capable of sustaining. Tensile strength is calculated from the maximum force during a tension test carried to rupture and the original cross-sectional area of the specimen. **E6**

4. Significance and Use

4.1 This test method may be used for material development, material comparison, quality assurance, characterization, reliability assessment, and design data generation.

4.2 Continuous fiber-reinforced ceramic matrix composites generally characterized by crystalline matrices and ceramic fiber reinforcements are candidate materials for structural applications requiring high degrees of wear and corrosion resistance, and elevated-temperature inherent damage tolerance (that is, toughness). In addition, continuous fiber-reinforced glass (amorphous) matrix composites are candidate materials for similar but possibly less-demanding applications. Although flexural test methods are commonly used to evaluate strengths of monolithic advanced ceramics, the non-uniform stress distribution of the flexure test specimen in addition to dissimilar mechanical behavior in tension and compression for CFCCs leads to ambiguity of interpretation of strength results obtained from flexure tests for CFCCs. Uniaxially-loaded tensile-strength tests provide information on mechanical behavior and strength for a uniformly stressed material.

4.3 Unlike monolithic advanced ceramics that fracture catastrophically from a single dominant flaw, CFCCs generally experience 'graceful' (that is, non-catastrophic, ductile-like stress-strain behavior) fracture from a cumulative damage process. Therefore, the volume of material subjected to a uniform tensile stress for a single uniaxially-loaded tensile test may not be as significant a factor in determining the ultimate strengths of CFCCs. However, the need to test a statistically significant number of tensile test specimens is not obviated. Therefore, because of the probabilistic nature of the strengths of the brittle fibers and matrices of CFCCs, a sufficient number of test specimens at each testing condition is required for statistical analysis and design. Studies to determine the influence of test specimen volume or surface area on strength distributions for CFCCs have not been completed. It should be noted that tensile strengths obtained using different recommended tensile test specimen geometries with different volumes of material in the gage sections may be different due to these volume differences.

4.4 Tensile tests provide information on the strength and deformation of materials under uniaxial tensile stresses. Uniform stress states are required to effectively evaluate any non-linear stress-strain behavior that may develop as the result of cumulative damage processes (for example, matrix cracking, matrix/fiber debonding, fiber fracture, delamination, and so forth) that may be influenced by testing mode, testing rate, effects of processing or combinations of constituent materials, environmental influences, or elevated temperatures. Some of these effects may be consequences of stress corrosion or sub critical (slow) crack growth that can be minimized by testing at sufficiently rapid rates as outlined in this test method.

4.5 The results of tensile tests of test specimens fabricated to standardized dimensions from a particular material or selected portions of a part, or both, may not totally represent the strength and deformation properties of the entire, full-size end product or its in-service behavior in different environments or various elevated temperatures.

4.6 For quality control purposes, results derived from standardized tensile test specimens may be considered indicative of the response of the material from which they were taken for the particular primary processing conditions and post-processing heat treatments.

4.7 The tensile behavior and strength of a CFCC are dependent on its inherent resistance to fracture, the presence of flaws, or damage accumulation processes, or both. Analysis of fracture surfaces and fractography, though beyond the scope of this test method, is recommended.

5. Interferences

5.1 Test environment (vacuum, inert gas, ambient air, etc.) including moisture content (for example, relative humidity) may have an influence on the measured tensile strength. In particular, the behavior of materials susceptible to slow crack growth fracture will be strongly influenced by test environment, testing rate, and elevated temperature of the test. Conduct tests to evaluate the maximum strength potential of a material in inert environments or at sufficiently rapid testing rates, or both, to minimize slow crack growth effects. Conversely, conduct tests in environments or at test modes, or both, and rates representative of service conditions to evaluate material performance under use conditions. Monitor and report relative humidity (RH) and temperature when testing is conducted in uncontrolled ambient air with the intent of evaluating maximum strength potential. Testing at humidity levels >65 % RH is not recommended.

5.2 Surface preparation of test specimens, although normally not considered a major concern in CFCCs, can introduce fabrication flaws which may have pronounced effects on tensile mechanical properties and behavior (for example, shape and level of the resulting stress-strain curve, tensile strength and strain, proportional limit stress and strain, and so forth). Machining damage introduced during test specimen preparation can be either a random interfering factor in the determination of ultimate strength of pristine material (that is, increase frequency of surface-initiated fractures compared to volume-initiated fractures), or an inherent part of the strength characteristics to be measured. Surface preparation can also lead to the introduction of residual stresses. Universal or standardized methods for surface preparation do not exist. In addition, the nature of fabrication used for certain composites (for example, chemical vapor infiltration or hot pressing) may require the testing of test specimens in the as-processed condition (that is, it may not be possible to machine the test specimen faces without compromising the in-plane fiber architecture). Final machining steps may, or may not negate machining damage introduced during the initial machining. Therefore, report test specimen fabrication history since it may play an important role in the measured strength distributions.

5.3 Bending in uniaxial tensile tests can cause or promote non-uniform stress distributions with maximum stresses occurring at the test specimen surface leading to non-representative fractures originating at surfaces or near geometrical transitions. Bending may be introduced from several sources including misaligned load trains, eccentric or misshaped test specimens, and non-uniformly heated test specimens or grips. In addition, if deformations or strains are measured at surfaces where maximum or minimum stresses occur, bending may introduce over or under measurement of strains depending on the location of the strain-measuring device on the test specimen. Similarly, fracture from surface flaws may be accentuated or suppressed by the presence of the non-uniform stresses caused by bending.

5.4 Fractures that initiate outside the uniformly-stressed gage section of a test specimen may be due to factors such as stress concentrations or geometrical transitions, extraneous stresses introduced by gripping, or strength-limiting features in the microstructure of the test specimen. Such non-gage section fractures will normally constitute invalid tests. In addition, for face-loaded geometries, gripping pressure is a key variable in the initiation of fracture. Insufficient pressure can shear the outer plies in laminated CFCCs; while too much pressure can cause local crushing of the CFCC and initiate fracture in the vicinity of the grips.

6. Apparatus

6.1 *Testing Machines*—Machines used for tensile testing shall conform to Practices E4. As defined in Practices E4, forces used in determining tensile strength shall be accurate within $\pm 1\%$ at any force within the selected force range of the testing machine. A schematic showing pertinent features of the tensile testing apparatus is shown in Fig. 1.

6.2 *Gripping Devices:*

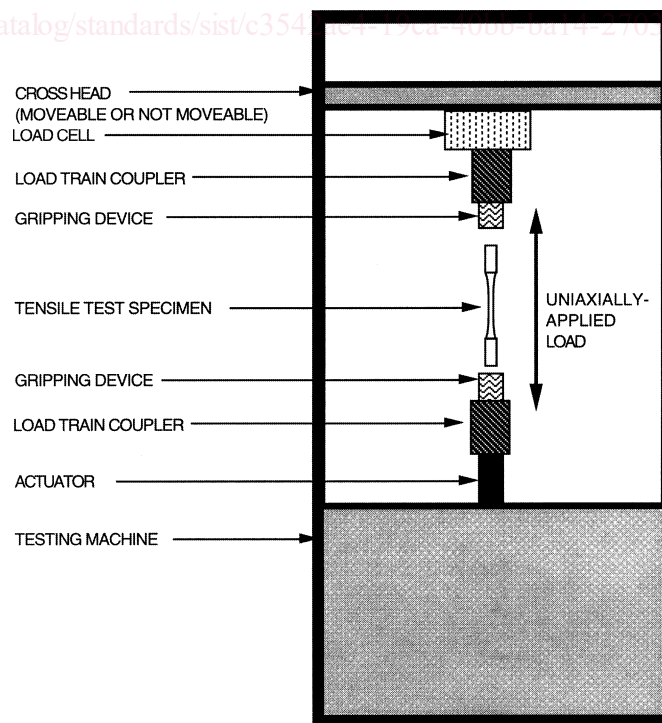

FIG. 1 Schematic Diagram of One Possible Apparatus for Conducting a Uniaxially-Loaded Tensile Test

6.2.1 *General*—Various types of gripping devices may be used to transmit the measured force applied by the testing machine to the test specimen. The brittle nature of the matrices of CFCCs requires a uniform interface between the grip components and the gripped section of the test specimen. Line or point contacts and non-uniform pressure can produce Hertzian-type stresses leading to crack initiation and fracture of the test specimen in the gripped section. Gripping devices can be classified generally as those employing active and those employing passive grip interfaces as discussed in the following paragraphs. Uncooled grips located inside the heated zone are termed “hot grips” and generally produce almost no thermal gradient in the test specimen but at the relative expense of grip materials of at least the same temperature capability as the test material and increased degradation of the grips due to exposure to the elevated-temperature oxidizing environment. Grips located outside the heated zone surrounding the test specimen may or may not employ cooling. Uncooled grips located outside the heated zone are termed “warm grips” and generally induce a mild thermal gradient in the test specimen but at the relative expense of elevated-temperature alloys in the grips and increased degradation of the grips due to exposure to the elevated-temperature oxidizing environment. Cooled grips located outside the heated zone are termed “cold grips” and generally induce a steep thermal gradient in the test specimen (as shown by example in Fig. 2) at a greater relative expense because of grip cooling equipment and allowances, although with the advantage of consistent alignment and little degradation from exposure to elevated temperatures.

NOTE 1—The expense of the cooling system for cold grips is balanced against maintaining alignment that remains consistent from test to test (stable grip temperature) and decreased degradation of the grips due to exposure to the elevated-temperature oxidizing environment. When grip cooling is employed, means should be provided to control the cooling medium to maximum fluctuations of 5 K (less than 1 K preferred) about a setpoint temperature (1)³ over the course of the test to minimize thermally-induced strain changes in the test specimen. In addition, opposing grip temperatures should be maintained at uniform and consistent temperatures within ±5 K (less than ±1 K preferred) (1) so as to avoid introducing unequal thermal gradients and subsequent non uniaxial stresses in the test specimen. Generally, the need for control of grip temperature fluctuations or differences may be indicated if test specimen gage-section temperatures cannot be maintained within the limits required in 9.3.2.

6.2.1.1 *Active Grip Interfaces*—Active grip interfaces require a continuous application of a mechanical, hydraulic, or pneumatic force to transmit the force applied by the test machine to the test specimen. Generally, these types of grip interfaces cause a force to be applied normal to the surface of the gripped section of the test specimen. Transmission of the uniaxial force applied by the test machine is then accomplished by friction between the test specimen and the grip faces. Thus, important aspects of active grip interfaces are uniform contact between the gripped section of the test specimen and the grip faces and constant coefficient of friction over the test specimen/grip interface. In addition, note that fixed-displacement active grips set at ambient temperatures, may introduce excessive gripping stresses due to thermal expansion of the test material when the test specimen is heated to the test temperature. Provide means to avoid such excessive stresses.

6.2.1.2 For flat test specimens, face-loaded grips, either by direct lateral pressure grip faces (2) or by indirect wedge-type grip faces, act as the grip interface (3) as illustrated in Fig. 3 and Fig. 4, respectively. Close tolerances are required for the flatness and parallelism as well as for the wedge angle of the wedge grip faces. In addition, the thickness, flatness, and parallelism of the gripped section of the test specimen must be within similarly close tolerances to promote uniform contact at the test specimen/grip interface. Tolerances will vary depending on the exact configuration as shown in the appropriate test specimen drawings.

6.2.1.3 Sufficient lateral pressure must be applied to prevent slippage between the grip face and the test specimen. Grip surfaces that are scored or serrated with a pattern similar to that of a single-cut file have been found satisfactory. A fine serration appears to be the most satisfactory. Keep the serrations clean and well-defined but not overly sharp. The length and width of the grip faces shall be equal to or greater than the respective length and width of the gripped sections of the test specimen.

³ The boldface numbers given in parentheses refer to a list of references at the end of the text.

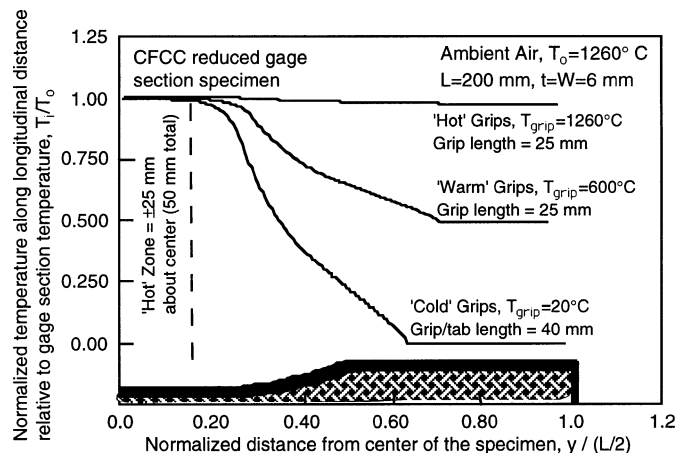

NOTE 1—Shape is that of a quarter section of a face-loaded tensile test specimen.

FIG. 2 Temperature Distributions in a Reduced Gage Section Test Specimen for Various Types of Gripping Arrangements

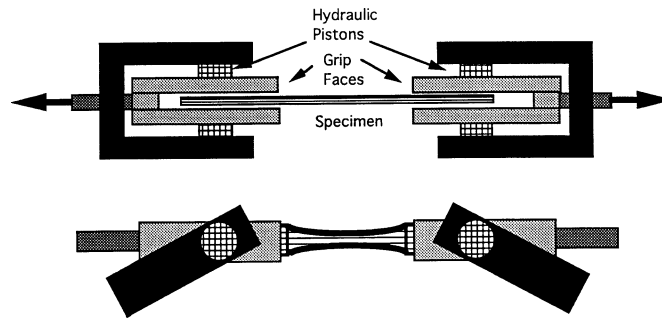

FIG. 3 Example of a Direct Lateral Pressure Grip Face for a Face-Loaded Grip Interface

6.2.1.4 *Passive Grip Interfaces*—Passive grip interfaces transmit the force applied by the test machine to the test specimen through a direct mechanical link. These mechanical links transmit the test forces to the test specimen via geometrical features of the test specimens such as shank shoulders or holes in the gripped head. Thus, the important aspect of passive grip interfaces is uniform contact between the gripped section of the test specimen and the grip faces.

6.2.1.5 For flat test specimens, passive grips may act either through edge-loading via grip interfaces at the shoulders of the test specimen shank (4) or by combinations of face-loading and pin loading via pins in the gripped test specimen head (5,6). Close tolerances of linear and angular dimensions of shoulder and grip interfaces are required to promote uniform contact along the entire test specimen/grip interface as well as to provide for non-eccentric loading as shown in Fig. 5. In addition, moderately close tolerances are required for center-line coincidence and diameters of the pins and hole as indicated in Fig. 6.

6.2.1.6 When using edge-loaded test specimens, lateral centering of the test specimen within the grip attachments is accomplished by use of wedge-type inserts machined to fit within the grip cavity. In addition, wear of the grip cavity can be reduced by use of the thin brass sheets between the grip and test specimen without adversely affecting test specimen alignment.

6.2.1.7 The pins in the face/pin loaded grip are primarily for alignment purposes and force transmission. Secondary force transmission is through face-loading via mechanically actuated wedge grip faces. Proper tightening of the wedge grip faces against the test specimen to prevent slipping while avoiding compressive fracture of the test specimen gripped section must be determined for each material and test specimen type.

6.2.1.8 Passive grips employing single pins in each gripped section of the test specimen as the primary force transfer mechanism are not recommended. Relatively low interfacial shear strengths compared to longitudinal tensile strengths in CFCCs (particularly for 1-D reinforced materials loaded along the fiber direction) may promote non-gage section fractures along interfaces particularly at geometric transitions or at discontinuities such as holes.

6.3 Force Train Couplers:

6.3.1 *General*—Various types of devices (load-train couplers) may be used to attach the active or passive grip interface assemblies to the testing machine. The load-train couplers in conjunction with the type of gripping device play major roles in the alignment of the load train and thus subsequent bending imposed in the test specimen. Load-train couplers can be classified generally as fixed and non-fixed as discussed in the following paragraphs. Use of well-aligned fixed or self-aligning non-fixed couplers does not automatically guarantee low bending in the gage section of the tensile test specimen. Well-aligned fixed or self-aligning non-fixed couplers provide for well-aligned load trains, but the type and operation of grip interfaces as well as the as-fabricated dimensions of the tensile test specimen can add significantly to the final bending imposed in the gage section of the test specimen.

6.3.1.1 Regardless of which type of coupler is used, verify alignment of the testing system at a minimum at the beginning and end of a test series unless the conditions for verifying alignment are otherwise met. An additional verification of alignment is recommended, although not required, at the middle of the test series. Use either a dummy or actual test specimen. Allowable bending requirements are discussed in 6.5. See Practice E1012 for discussions of alignment and X1 for suggested procedures specific to this test method. A test series is interpreted to mean a discrete group of tests on individual test specimens conducted within a discrete period of time on a particular material configuration, test specimen geometry, test condition, or other uniquely definable qualifier (for example, a test series composed of material A comprising ten test specimens of geometry B tested at a fixed rate in strain control to final fracture in ambient air).

NOTE 2—Tensile test specimens used for alignment verification should be equipped with a recommended eight separate longitudinal strain gages to determine bending contributions from both eccentric and angular misalignment of the grip heads. Ideally the verification test specimen should be of identical material to that being tested. However, in the case of CFCCs, the type of reinforcement or degree of residual porosity may complicate the consistent and accurate measurement of strain. Therefore, an alternate material (isotropic, homogeneous, continuous) with similar elastic modulus, elastic strain capability, and hardness to the test material may be used. In addition, dummy test specimens used for alignment verification, should have the same geometry and dimensions of the actual test specimens as well as similar mechanical properties as the test material to ensure similar axial and bending stiffness characteristics as the actual test specimen and material.

6.3.2 *Fixed Load-Train Couplers*—Fixed couplers may incorporate devices which require either a one-time, pre-test alignment adjustment of the load train that remains constant for all subsequent tests or an *in situ*, pre-test alignment of the load train which

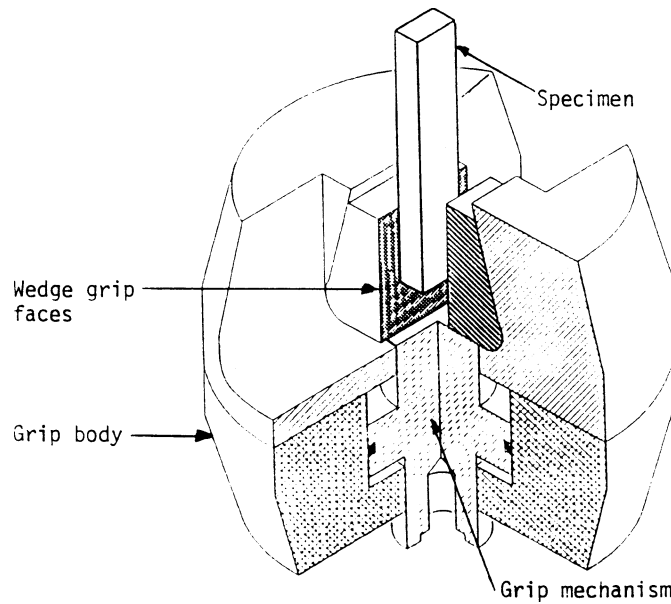

FIG. 4 Example of Indirect Wedge-Type Grip Faces for a Face-Loaded Grip Interface

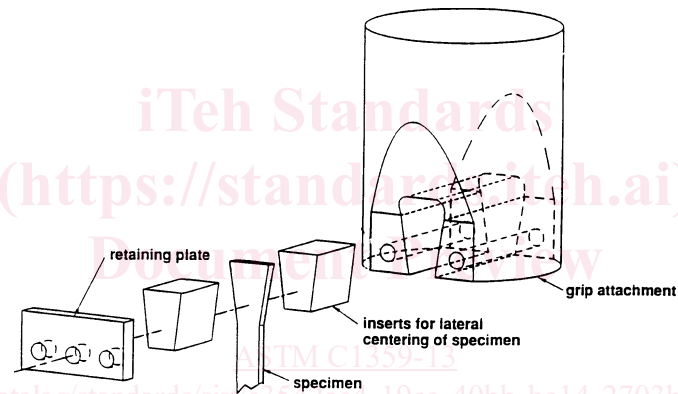

FIG. 5 Example of a Edge-Loaded, Passive Grip Interface (4)

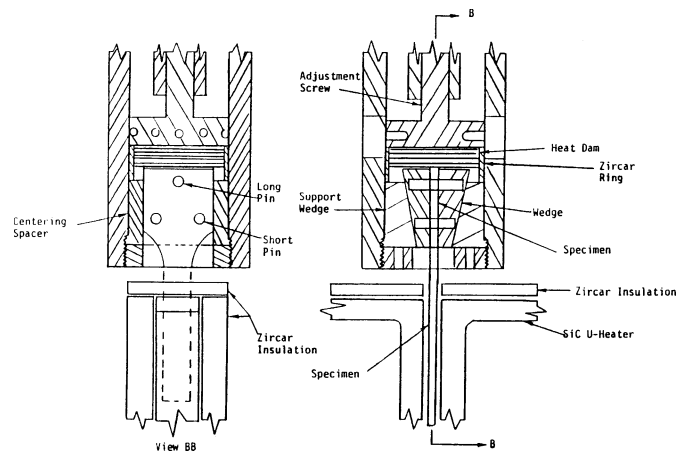

FIG. 6 Example of Pin/Face-Loaded Passive Grip Interface (5)

is conducted separately for each test specimen and each test. Such devices (7,8) usually employ angularity and concentricity adjusters to accommodate inherent load-train misalignments. Regardless of which method is used, verify alignment verification as discussed in 6.3.1.1.

6.3.2.1 Fixed load-train couplers are preferred in the monotonic testing of CFCCs because of the fracture behavior in these materials. During the fracture process of CFCCs, the fixed coupler tends to hold the test specimen in an aligned position and thus provides a continuous uniform stress across the remaining ligament of the gage section.

6.3.3 *Non Fixed Load-Train Couplers*—Non fixed couplers may incorporate devices which promote self-alignment of the load train during the movement of the crosshead or actuator. Such devices rely upon freely moving linkages to eliminate applied moments as the load-train components are loaded. Knife edges, universal joints, hydraulic couplers, or air bearings are examples (5,9,10) of such devices. Examples of two such devices are shown in Fig. 7. Although non-fixed load-train couplers are designed to be self-aligning and thus eliminate the need to evaluate the bending in the test specimen for each test, this alignment must be confirmed. Verify the operation of the couplers as discussed in 6.3.1.1.

6.3.3.1 Non-fixed load-train couplers are useful in testing of CFCCs at rapid test rates or in load control where the cumulative-damage fracture process may not be as macroscopically apparent. If the material exhibits such fracture behavior the self-aligning feature of the non-fixed coupler allows rotation of the gripped section of the test specimen thus promoting a non-uniform stress in the remaining ligament of the gage section.

6.4 *Strain Measurement*—Determine strain at elevated temperatures by means of a suitable extensometer.

6.4.1 Extensometers used for tensile testing of CFCC test specimens shall satisfy Practice E83, Class B-1 requirements. Calibrate extensometers periodically in accordance with Practice E83. For extensometers which mechanically contact the test specimen, the contact shall not cause damage to the test specimen surface. However, shallow grooves (0.025 to 0.051 mm deep) machined into the surfaces of CFCCs to prevent extensometer slippage have been shown to not have a detrimental effect on failure strengths at elevated temperatures (5). Choose extensometer contact probes which are chemically compatible with the test material (for example, alumina extensometer extensions and SiC CFCC are incompatible). In addition, support the weight of the extensometer so as not to introduce bending greater than that allowed in 6.5. Finally, configure the tips of the probes of contacting extensometers (for example, sharp, knife edges, or chisel tips) so as to minimize slippage.

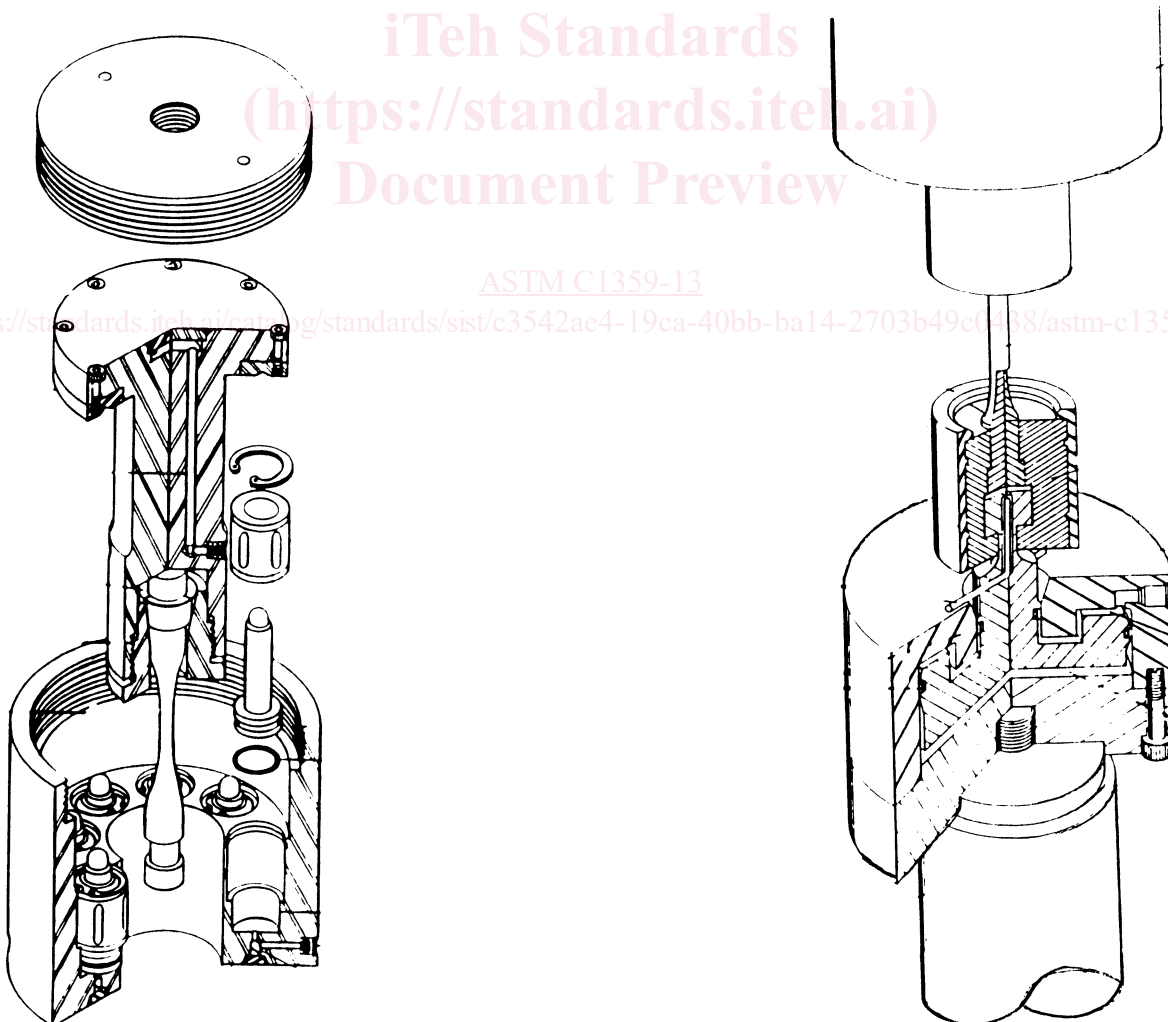

FIG. 7 Examples of Hydraulic, Self-Aligning, Non Fixed Load Train Couplers (9,10)

6.5 *Allowable Bending*—Analytical and empirical studies (11) have concluded that for negligible effects on the estimates of the strength distribution parameters (for example, Weibull modulus, m^{\wedge} , and characteristic strength, σ^{\wedge}_0) of monolithic advanced ceramics, allowable percent bending as defined in Practice E1012 should not exceed five. These conclusions (11) assume that tensile strength fractures are due to single fracture origins in the volume of the material, all tensile test specimens experienced the same level of bending, and that Weibull modulus, m^{\wedge} , was constant.

6.5.1 Similar studies of the effect of bending on the tensile strength distributions of CFCCs do not exist. Until such information is forthcoming for CFCCs, this test method adopts the recommendations for tensile testing of monolithic advanced ceramics. Therefore, the recommended maximum allowable percent bending at the onset of the cumulative fracture process (for example, matrix cracking stress) for test specimens tested under this test method is five. Verify the testing system such that percent bending does not exceed five at a mean strain equal to either one half the anticipated strain at the onset of the cumulative fracture process (for example, matrix cracking stress) or a strain of 0.0005 (that is, 500 micro strain) whichever is greater. Unless all test specimens are properly strain gaged and percent bending monitored until the onset of the cumulative fracture process, there will be no record of percent bending at the onset of fracture for each test specimen. Therefore, verify the alignment of the testing system. See Practice E1012 for discussions of alignment and X1 for suggested procedures specific to this test method.

6.6 *Heating Apparatus*—The apparatus for, and method of, heating the test specimens shall provide the temperature control necessary to satisfy the requirement of 9.3.2.

6.6.1 Heating can be by indirect electrical resistance (heating elements), direct induction, indirect induction through a susceptor, or radiant lamp with the test specimen in ambient air at atmospheric pressure unless other environments are specifically applied and reported.

NOTE 3—Direct resistance heating is not recommended for heating CFCCs due to possible differences of the electrical resistances of the constituent materials that may produce nonuniform heating of the test specimen.

6.7 *Temperature-Measuring Apparatus*—The method of temperature measurement shall be sufficiently sensitive and reliable to ensure that the temperature of the test specimen is within the limits specified in 9.3.2.

6.7.1 For test temperatures less than 2000 K, make primary temperature measurements with noble-metal thermocouples in conjunction with potentiometers, millivoltmeters, or electronic temperature controllers or readout units, or all of these. Such measurements are subject to two types of error as discussed in MNL 12 (12). Firstly, thermocouple calibration and instrument measuring errors initially produce uncertainty as to the exact temperature. Secondly, both thermocouples and measuring instruments may be subject to variations over time. Common errors encountered in the use of thermocouples to measure temperatures include: calibration error, drift in calibration due to contamination or deterioration with use, lead-wire error, error arising from method of attachment to the test specimen, direct radiation of heat to the bead, heat conduction along thermocouple wires, etc.

6.7.1.1 Measure temperature with thermocouples of known calibration (calibrated according to Test Method E220). Calibrate representative thermocouples from each lot of wires used for making noble (for example, Pt or Rh/Pt) metal thermocouples. Except for relatively low temperatures of exposure, noble-metal thermocouples are eventually subject to error upon reuse, unless the depth of immersion and temperature gradients of the initial exposure are reproduced. Consequently, calibrate noble-metal thermocouples using representative thermocouples. Do not reuse degraded noble-metal thermocouples without proper treatment. This treatment includes clipping back the wire exposed to the hot zone, rewelding a thermocouple bead, and properly annealing the rewelded thermocouple bead and wire. Any reuse of noble-metal thermocouples (except after relatively low-temperature use) without this precautionary treatment shall be accompanied by recalibration data demonstrating that calibration of the temperature reading system was not unduly affected by the conditions of exposure.

6.7.1.2 Measurement of the drift in calibration of thermocouples during use is difficult. When drift is a problem during tests, devise a method to check the readings of the thermocouples on the test specimen during the test. For reliable calibration of thermocouples after use, reproduce the temperature gradient of the test furnace during the recalibration.

6.7.1.3 Thermocouples containing Pt are also subject to degradation in the presence of silicon and silicon-containing compounds. Platinum silicides may form leading to several possible outcomes. One outcome is the embrittlement of the noble-metal thermocouple tips and their eventual degradation and breakage. Another outcome is the degradation of the silicon-containing material (for example, test specimen, furnace heating elements, or refractory furnace materials). In all cases, do not allow platinum containing materials to contact silicon containing materials. In particular, do not allow noble-metal thermocouples to contact silicon-based test materials (for example, SiC or Si₃N₄). In some cases (for example, when using SiC heating elements), it is advisable to use ceramic-shielded noble-metal thermocouples to avoid the reaction of the Pt-alloy thermocouples with the SiO gas generated by the volatilization of the SiO₂ protective layers of SiC heating elements.

6.7.1.4 Calibrate temperature-measuring, controlling, and recording instruments versus a secondary standard, such as precision potentiometer, optical pyrometer, or black-body thyristor. Check lead-wire error with the lead wires in place as they normally are used.

6.7.2 For test temperatures greater than 2000 K, less-common temperature measurement devices such as thermocouples of elevated-temperature, non noble-metal alloys (for example, W-Re) or optical pyrometry may be used. Since widely-recognized standards do not exist for these less-common devices, report the type of measurement device, its method of calibration, and its accuracy and precision.

6.8 *Data Acquisition*—At a minimum, obtain an autographic record of applied load and gage section elongation or strain versus time. Either analog chart recorders or digital data acquisition systems can be used for this purpose although a digital record is recommended for ease of later data analysis. Ideally, use an analog chart recorder or plotter in conjunction with the digital data acquisition system to provide an immediate record of the test as a supplement to the digital record. Recording devices shall be accurate to within $\pm 1.0\%$ of the selected range for the testing system including readout unit, as specified in Practices E4, and should have a minimum data acquisition rate of 10 Hz with a response of 50 Hz deemed more than sufficient.

6.8.1 Record strain or elongation, or both, of the gage section either similarly to the force or as independent variables of force. Cross-head displacement of the test machine may also be recorded but should not be used to define displacement or strain in the gage section especially when self-aligning couplers are used in the load train.

6.8.2 At a minimum, record temperature as single points at the initiation and completion of the actual test. However, temperature can also be recorded similarly to force and strain except the record can begin at the start of the heating of the furnace (including ramp-up to test temperature) and ending at the completion of the test.

6.9 *Dimension-Measuring Devices*—Micrometres and other devices used for measuring linear dimensions shall be accurate and precise to at least one half the smallest unit to which the individual dimension is required to be measured. For the purposes of this test method, cross-sectional dimensions shall be measured to within 0.02 mm using dimension measuring devices with accuracies of 0.01 mm.

7. Precautionary Statement

7.1 During the conduct of this test method, the possibility of flying fragments of broken test material may be great. The brittle nature of advanced ceramics and the release of strain energy contribute to the potential release of uncontrolled fragments upon fracture. Means for containment and retention of these fragments for safety as well as later fractographic reconstruction and analysis is recommended.

7.2 Exposed fibers at the edges of CFCC test specimens present a hazard due to the sharpness and brittleness of the ceramic fiber. Inform all persons required to handle these materials of such conditions and the proper handling techniques.

8. Test Specimen

8.1 *Test Specimen Geometry:*

8.1.1 *General*—The geometry of tensile test specimens is dependent on the ultimate use of the tensile strength data. For example, if the tensile strength of an as-fabricated component is required, the dimensions of the resulting tensile test specimen may reflect the thickness, width, and length restrictions of the component. If it is desired to evaluate the effects of interactions of various constituent materials for a particular CFCC manufactured via a particular processing route, then the size of the test specimen and resulting gage section will reflect the desired volume or surface area to be sampled. In addition, grip interfaces and load-train couplers as discussed in Section 6 will influence the final design of the test specimen geometry.

8.1.1.1 The following paragraphs discuss the more common, and thus proven, of these test specimen geometries although any geometry is acceptable if it meets the gripping, fracture location, bending, and temperature profile requirements of this test method. Deviations from the recommended geometries may be necessary depending upon the particular CFCC being evaluated. Conduct stress analyses of untried test specimens to ensure that stress concentrations which can lead to undesired fractures outside the gage sections do not exist. Contoured test specimens by their nature contain inherent stress concentrations due to geometric transitions. Stress analyses can indicate the magnitude of such stress concentrations while revealing the success of producing a uniform tensile stress state in the gage section of the test specimen. Additionally, the success of an elevated-temperature tensile test will depend on the type of heating system, extent of test specimen heating, and test specimen geometry since these factors are all interrelated. For example, thermal gradients may introduce additional stress gradients in test specimens which may already exhibit stress gradients at ambient temperatures due to geometric transitions. Therefore, analyze untried test configurations simultaneously for both loading-induced stress gradients and thermally-induced temperature gradients to ascertain any adverse interactions.

8.1.1.2 Test specimens with contoured gage sections (transition radii of > 50 mm) are preferred to promote the tensile stresses with the greatest values in the uniformly-stressed gage section (13) while minimizing the stress concentration due to the geometrical transition of the radius. However, in certain instances, (for example, 1-D CFCCs tested along the direction of the fibers) low interfacial shear strength relative to the tensile strength in the fiber direction will cause splitting of the test specimen initiating at the transition region between the gage section and the gripped section of the test specimen with the split propagating along the fiber direction leading to fracture of the test specimen. In these cases, straight-sided (that is, non-contoured) test specimens as shown in Fig. 8, may be required for determining the tensile strength behavior of the CFCC. In other instances, a particular fiber weave or processing route will preclude fabrication of test specimens with reduced gage sections, thus requiring implementation of straight-sided test specimens. Straight-sided test specimens may be gripped in any of the methods discussed here although active gripping systems are recommended for minimizing non-gage section fractures.

8.1.1.3 When testing woven fabric laminate composites, it is recommended that the gage length and width equal, at a minimum, one length and one width of the weave unit cell. (Unit cell count = 1 across the given dimension.) Two or more weave unit cells are preferred across a given gage dimension.

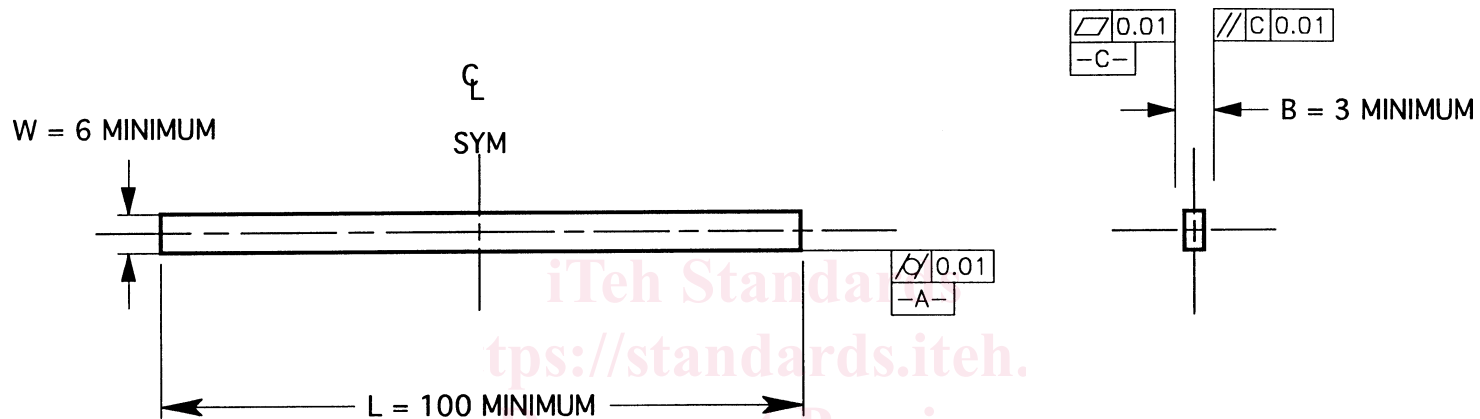

- NOTE: 1) MINIMUM L = 100 mm WITH 25 mm GAGE SECTION. MINIMUM W = 6 mm.
 2) SURFACE FINISH 0.5- 1.0 μm ALL OVER EXCEPT END FACES WHICH MAY BE 1.0-2.0 μm .
 3) FINAL GRIND OF GAGE SECTION TO BE LONGITUDINAL

Tensile Specimen for CFCCs
mm X.X = 0.1, X.XX = 0.01, X.XXX = 0.001 SCALE: NTS

NOTE 1—Illustration not intended to be an engineering or production drawing, or both.

FIG. 8 Example of Straight-Sided Test Specimen Geometry