



Designation: ~~C1425 – 11~~ C1425 – 13

Standard Test Method for Interlaminar Shear Strength of 1–D and 2–D Continuous Fiber-Reinforced Advanced Ceramics at Elevated Temperatures¹

This standard is issued under the fixed designation C1425; the number immediately following the designation indicates the year of original adoption or, in the case of revision, the year of last revision. A number in parentheses indicates the year of last reappraisal. A superscript epsilon (ϵ) indicates an editorial change since the last revision or reappraisal.

1. Scope-~~Scope~~*

1.1 This test method addresses the compression of a double-notched test specimen to determine interlaminar shear strength of continuous fiber-reinforced ceramic composites (CFCCs) at elevated temperatures. Failure of the test specimen occurs by interlaminar shear between two centrally located notches machined halfway through the thickness of the test specimen and spaced a fixed distance apart on opposing faces (see Fig. 1). Test specimen preparation methods and requirements, testing modes (force or displacement control), testing rates (force rate or displacement rate), data collection, and reporting procedures are addressed.

1.2 This test method is used for testing advanced ceramic or glass matrix composites with continuous fiber reinforcement having a laminated structure such as in unidirectional (1-D) or bidirectional (2-D) fiber architecture (lay-ups of unidirectional plies or stacked fabric). This test method does not address composites with nonlaminated structures, such as (3-D) fiber architecture or discontinuous fiber-reinforced, whisker-reinforced, or particulate-reinforced ceramics.

1.3 Values expressed in this test method are in accordance with the International System of Units (SI) and **IEEE/ASTM SI 10**.

1.4 *This standard does not purport to address all of the safety concerns, if any, associated with its use. It is the responsibility of the user of this standard to establish appropriate safety and health practices and determine the applicability of regulatory limitations prior to use.* Specific precautionary statements are noted in 8.1 and 8.2.

2. Referenced Documents

2.1 ASTM Standards:²

[C1145 Terminology of Advanced Ceramics](#)

[C1292 Test Method for Shear Strength of Continuous Fiber-Reinforced Advanced Ceramics at Ambient Temperatures](#)

[D695 Test Method for Compressive Properties of Rigid Plastics](#)

[D3846 Test Method for In-Plane Shear Strength of Reinforced Plastics](#)

[D3878 Terminology for Composite Materials](#)

[D6856/D6856M Guide for Testing Fabric-Reinforced “Textile” Composite Materials](#)

[E4 Practices for Force Verification of Testing Machines](#)

[E6 Terminology Relating to Methods of Mechanical Testing](#)

[E122 Practice for Calculating Sample Size to Estimate, With Specified Precision, the Average for a Characteristic of a Lot or Process](#)

[E220 Test Method for Calibration of Thermocouples By Comparison Techniques](#)

[E230 Specification and Temperature-Electromotive Force \(EMF\) Tables for Standardized Thermocouples](#)

[E337 Test Method for Measuring Humidity with a Psychrometer \(the Measurement of Wet- and Dry-Bulb Temperatures\)](#)

[IEEE/ASTM SI 10 American National Standard for Use of the International System of Units \(SI\): The Modern Metric System](#)

¹ This test method is under the jurisdiction of ASTM Committee C28 on Advanced Ceramics and is the direct responsibility of Subcommittee C28.07 on Ceramic Matrix Composites.

Current edition approved July 15, 2011; Feb. 15, 2013. Published August 2011; April 2013. Originally approved in 1999. Last previous edition approved in 2005 as C1425 – 05; C1425 – 11. DOI: 10.1520/C1425-11; 10.1520/C1425-13.

² For referenced ASTM standards, visit the ASTM website, www.astm.org, or contact ASTM Customer Service at service@astm.org. For *Annual Book of ASTM Standards* volume information, refer to the standard’s Document Summary page on the ASTM website.

*A Summary of Changes section appears at the end of this standard

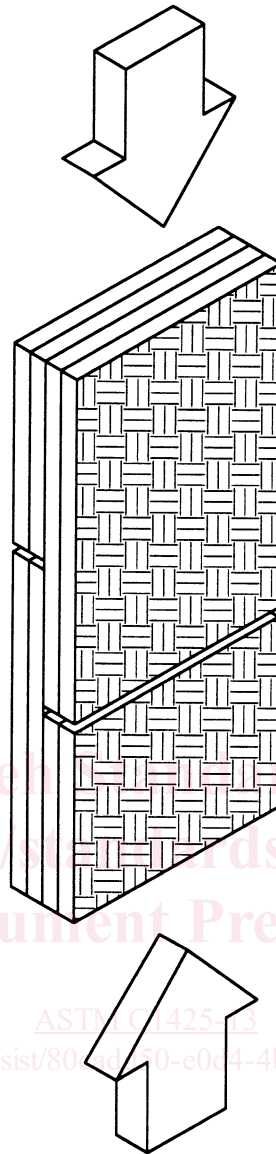

FIG. 1 Schematic of Compression of Double-Notched Test Specimen for the Determination of Interlaminar Shear Strength of CFCCs

3. Terminology

3.1 *Definitions*—The definitions of terms relating to shear strength testing appearing in Terminology E6 apply to the terms used in this test method. The definitions of terms relating to advanced ceramics appearing in Terminology C1145 apply to the terms used in this test method. The definitions of terms relating to fiber-reinforced composites appearing in Terminology D3878 apply to the terms used in this test method.

3.2 *Definitions of Terms Specific to This Standard:*

3.2.1 *shear failure force (F), n*—maximum force required to fracture a shear-loaded test specimen. (C1292)

3.2.2 *shear strength (FL⁻²), n*—maximum shear stress that a material is capable of sustaining. Shear strength is calculated from the failure force in shear and the shear area. (C1292)

4. Summary of Test Method

4.1 This test method addresses the determination of the interlaminar shear strength of CFCCs at elevated temperatures. The interlaminar shear strength of CFCCs, as determined by this test method, is measured by loading in compression a double-notched test specimen of uniform width. Failure of the test specimen occurs by interlaminar shear between two centrally located notches machined halfway through the thickness of the test specimen and spaced a fixed distance apart on opposing faces. Schematics of the loading mode and the test specimen are shown in Fig. 1. The procedures in this test method are similar to those in Test Method C1292 for the determination of the interlaminar shear strength of CFCCs at ambient temperature, except that the considerations for conducting the test at elevated temperatures are addressed in this test method.

5. Significance and Use

5.1 Continuous fiber-reinforced ceramic composites are candidate materials for structural applications requiring high degrees of wear and corrosion resistance, and damage tolerance at high temperatures.

5.2 The 1-D and 2-D CFCCs are highly anisotropic and their transthickness tensile and interlaminar shear strength are lower than their in-plane tensile and in-plane shear strength, respectively.

5.3 Shear tests provide information on the strength and deformation of materials under shear stresses.

5.4 This test method may be used for material development, material comparison, quality assurance, characterization, and design data generation.

5.5 For quality control purposes, results derived from standardized shear test specimens may be considered indicative of the response of the material from which they were taken for given primary processing conditions and post-processing heat treatments.

6. Interferences

6.1 Test environment (vacuum, inert gas, ambient air, and so forth) including moisture content (for example, relative humidity) may have an influence on the measured interlaminar shear strength. In particular, the behavior of materials susceptible to slow crack growth will be strongly influenced by test environment and testing rate. Testing to evaluate the maximum strength potential of a material shall be conducted in inert environments or at sufficiently rapid testing rates, or both, so as to minimize slow crack growth effects. Conversely, testing can be conducted in environments and testing modes and rates representative of service conditions to evaluate material performance under those conditions. When testing is conducted in uncontrolled ambient air with the objective of evaluating maximum strength potential, relative humidity and temperature must be monitored and reported. Testing at humidity levels >65 % RH is not recommended and any deviations from this recommendation must be reported.

6.2 Preparation of test specimens, although normally not considered a major concern with CFCCs, can introduce fabrication flaws which may have pronounced effects on the mechanical properties and behavior (for example, shape and level of the resulting force-displacement curve and shear strength). Machining damage introduced during test specimen preparation can be either a random interfering factor in the determination of shear strength of pristine material, or an inherent part of the strength characteristics to be measured. Universal or standardized test methods of surface preparation do not exist. Final machining steps may, or may not, negate machining damage introduced during the initial machining. Thus, test specimen fabrication history may play an important role in the measured strength distributions and shall be reported.

6.3 Bending in uniaxially loaded shear tests can cause or promote non-uniform stress distributions that may alter the desired state of stress during the test. For example, non-uniform loading will occur if the loading surfaces of the test specimen are not flat and parallel.

6.4 Fractures that initiate outside the gage section of a test specimen may be due to factors such as localized stress concentrations, extraneous stresses introduced by improper loading configurations, or strength-limiting features in the microstructure of the test specimen. Such non-gage section fractures will normally constitute invalid tests.

6.5 For the evaluation of the interlaminar shear strength by the compression of a double-notched test specimen, the distance between the notches has an effect on the maximum force and therefore on the interlaminar shear strength.^{3,4,5} It has been found that the stress distribution in the gage section of the test specimen is independent of the distance between the notches when the notches are far apart. However, when the distance between the notches is such that the stress fields around the notches interact, the measured interlaminar shear strength increases. Because of the complexity of the stress field around each notch and its dependence on the properties and homogeneity of the material, conduct a series of tests on test specimens with different spacing between the notches to determine the effect of notch separation on the measured interlaminar shear strength.

6.6 For the evaluation of the interlaminar shear strength by the compression of a double-notched test specimen, excessive clamping forces will reduce the stress concentration around the notches and, therefore, artificially increase the measured interlaminar shear strength. Excessive clamping might occur if interference between the test fixture and the test specimen results from mismatch in their thermal expansion. Section 7.6 provides guidance to prevent this problem.

6.7 The interlaminar shear strength of 1-D and 2-D CFCCs is controlled either by the matrix-rich interlaminar regions or by the weakest of the fiber-matrix interfaces. Whether interlaminar-shear failure initiates at the matrix-rich interlaminar region or at the weakest of the fiber/matrix interfaces depends on the location of the root of the notch, where the interlaminar shear stress is largest, with respect to the interlaminar microstructural features.

³ Whitney, J. M., "Stress Analysis of the Double Notch Shear Specimen," *Proceedings of the American Society for Composites*, 4th Technical Conference, Blacksburg, VA, Technomic Publishing Co., Oct. 3-5, 1989, pp. 325.

⁴ Fang, N. J. J., and Chou, T. W., "Characterization of Interlaminar Shear Strength of Ceramic Matrix Composites," *Journal Am. Ceram. Soc.*, 76, [10] 1993, pp. 2539-48.

⁵ Lara-Curzio, E., and Ferber, M. K., "Shear Strength of Continuous Fiber Reinforced Ceramic Composites," in *Thermal and Mechanical Test Methods and Behavior of Continuous Fiber Ceramic Composites*, ASTM STP 1309M, G. Jenkins, S. T. Gonczy, E. Lara-Curzio, N. E. Ashbaugh, and L. P. Zawada, eds., American Society for Testing and Materials, Philadelphia, PA, 1996.

7. Apparatus

7.1 *Testing Machines*—The testing machine shall be in conformance with Practices E4. The forces used in determining shear strength shall be accurate within $\pm 1\%$ at any force within the selected force range of the testing machine as defined in Practices E4.

7.2 *Heating Apparatus*—The apparatus for, and method of, heating the test specimens shall provide the temperature control necessary to satisfy the requirement of 10.2.

7.2.1 Heating can be by indirect electrical resistance (heating elements), indirect induction through a susceptor, or radiant lamp with the test specimen in ambient air at atmospheric pressure unless other environments are specifically applied and reported. Note that direct resistance heating is not recommended for heating CFCCs due to possible differences of the electrical resistance of the constituent materials which may produce nonuniform heating of the test specimen.

7.3 *Temperature-Measuring Apparatus*—The method of temperature measurement shall be sufficiently sensitive and reliable to ensure that the temperature of the test specimen is within the limits specified in 10.2.

7.3.1 Primary temperature measurement shall be made with thermocouples in conjunction with potentiometers, millivoltmeters, or electronic temperature controllers or readout units, or combination thereof. Such measurements are subject to two types of error. Thermocouple calibration and instrument measuring errors initially produce uncertainty as to the exact temperature. Secondly, both thermocouples and measuring instruments may be subject to variations over time. Common errors encountered in the use of thermocouples to measure temperatures include: calibration error, drift in calibration due to contamination or deterioration with use, lead-wire error, error arising from method of attachment to the test specimen, direct radiation of heat to the bead, heat conduction along thermocouple wires, and so forth.

7.3.2 Temperature measurements shall be made with thermocouples of known calibration. Representative thermocouples shall be calibrated from each lot of wires used for making noble-metal (for example, platinum or rhodium) thermocouples. Except for relatively low temperatures of exposure, noble-metal thermocouples are eventually subject to error upon reuse. Oxidized noble-metal thermocouples shall not be reused without clipping back to remove wire exposed to the hot zone, re-welding, and annealing. Any reuse of noble-metal thermocouples after relatively low-temperature use without this precaution shall be accompanied by re-calibration data demonstrating that calibration was not unduly affected by the conditions of exposure.

7.3.3 Measurement of the drift in calibration of thermocouples during use is difficult. When drift is a problem during tests, a method shall be devised to check the readings of the thermocouples monitoring the test specimen temperature during the test. For reliable calibration of thermocouples after use, the temperature gradient of the test furnace must be reproduced during the re-calibration.

7.3.4 Temperature-measuring, controlling, and recording instruments shall be calibrated against a secondary standard, such as precision potentiometer, optical pyrometer, or black-body thyristor. Lead-wire error shall be checked with the lead wires in place as they normally are used. For thermocouple calibration procedures refer to Test Method E220 and Specification E230.

7.4 *Data Acquisition*—At a minimum, autographic records of applied force and cross-head displacement versus time shall be obtained. Either analog chart recorders or digital data acquisition systems may be used for this purpose although a digital record is recommended for ease of later data analysis. Ideally, an analog chart recorder or plotter shall be used in conjunction with the digital data acquisition system to provide an immediate record of the test as a supplement to the digital record. Recording devices must be accurate to $\pm 1\%$ of full scale and shall have a minimum data acquisition rate of 10 Hz with a response of 50 Hz deemed more than sufficient.

7.5 *Dimension-Measuring Devices*—Micrometers and other devices used for measuring linear dimensions must be accurate and precise to at least 0.01 mm.

7.6 *Test Fixture*—The main purposes of the test fixture are to allow for uniform axial compression of the test specimen, and to provide lateral support to prevent buckling. Fig. 2a and 2b show schematics of test fixtures that have been used successfully to evaluate the interlaminar shear strength of CFCCs at elevated temperatures. Fig. 2a. shows the schematic of a test fixture consisting of a slotted body and one loading piston. Fig. 2b shows the schematic of a test fixture consisting of one hollow cylinder (sleeve), two pistons, and two semicylindrical spacers. A supporting jig conforming to the geometry of that shown in Figure 1 of Test Method D3846 or in Figure 4 of Test Method D695 may also be used. The material used for the manufacture of the test fixture should be stable and remain rigid at the test temperature. When using a slotted-body or two semicylindrical spacers as suggested in Fig. 2a and 2b, select their dimensions so that a gap not larger than 1 % of the test specimen thickness exists between the test specimen and each spacer (or between the test specimen and the walls of the slotted body) at the test temperature. To facilitate this requirement, use a compliant interphase between the test specimen and the spacers (or walls of the slotted body). This compliant interphase will also be useful for the purpose of accommodating thermally induced deformation. To prevent mechanical interference between the test fixture and the test specimen and avoid compressing the test specimen at the test temperature, it is recommended to manufacture the test fixture using a material with equal or higher coefficient of thermal expansion than that of the test specimen in its thickness direction. To ensure uniform axial loading, the pistons should be concentric with, and form a tight clearance fit with, the sleeve or hollow cylinder (that is, the pistons should be able to slide without friction within the sleeve). This can be achieved by meeting tight cylindricity requirements for the inner diameter of the sleeve and the outer diameter of the piston.

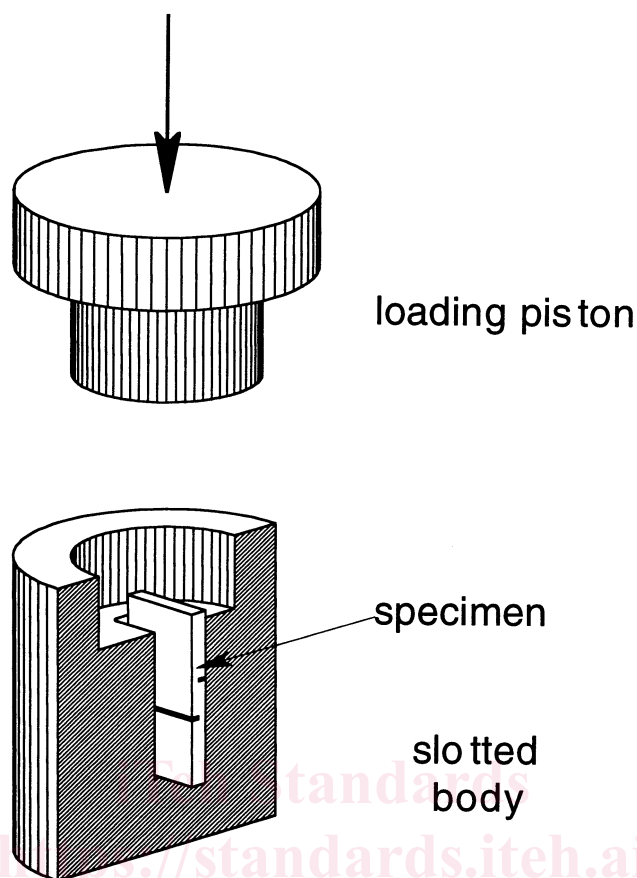

FIG. 2 Schematic of Test Fixture for the Compression of Double-Notched Test Specimens at Elevated Temperatures

NOTE 1—The material used to construct the test fixture shall be thermochemically stable and rigid at the test temperature: (a) Sectioned view of test fixture using one piston and one slotted base (b) Cross-sectional view of test fixture using two pistons and two semicylindrical spacers.

NOTE 2—0.70 mm thick aluminum-oxide paper has worked well as an interphase between 3.0-mm thick 2-D ceramic grade and Hi-Nicalon/SiC⁶ CFCCs and a α -SiC test fixture for tests in air at elevated temperatures. 0.79 mm thick GRAFOIL⁷ has worked well as an interphase between 6.0-mm thick 1-D C/C CFCC and an aluminum-oxide test fixture for tests in inert environment at elevated temperatures.⁸

8. Precautionary Statement

8.1 During the conduct of this test method, the possibility of flying fragments of broken test material may be high. The brittle nature of advanced ceramics and the release of strain energy contribute to the potential release of uncontrolled fragments upon fracture. Means for containment and retention of these fragments for later fractographic reconstruction and analysis is highly recommended.

8.2 Exposed fibers at the edges of CFCC test specimens present a hazard due to the sharpness and brittleness of the ceramic fibers. All persons required to handle these materials must be well informed of these conditions and the proper handling techniques.

9. Test Specimen

9.1 *Test Specimen Geometry*—The test specimens shall conform to the shape and tolerances shown in Fig. 3. The test specimen consists of a rectangular plate with notches machined on both sides. The depth of the notches shall be at least equal to one half of the test specimen thickness, and the distance between the notches shall be determined considering the requirements to produce shear failure in the gage section. Furthermore, because the measured interlaminar shear strength may be dependent on the notch separation, it is recommended to conduct tests with different values of notch separation to determine this dependence. The edges of the test specimens shall be smooth, but not rounded or beveled. Table 1 contains recommended values for the dimensions associated with the test specimen shown in Fig. 3.

⁶ Hi-Nicalon/SiC, a registered trademark of UCAR Carbon Company, Inc. P. O. Box 218, Columbia, TN 38402-0218, has been found satisfactory for this purpose.

⁷ GRAFOIL, a registered trademark a registered trademark of UCAR Carbon Company, Inc. P. O. Box 218, Columbia, TN 38402-0218, has been found satisfactory for this purpose.

⁸ Lara-Curzio, E., Bowers, David, and Ferber, M. K., "The Interlaminar Tensile and Shear Properties of a Unidirectional C/C Composite," *Journal of Nuclear Materials*, 230, 1996, pp. 226-32.

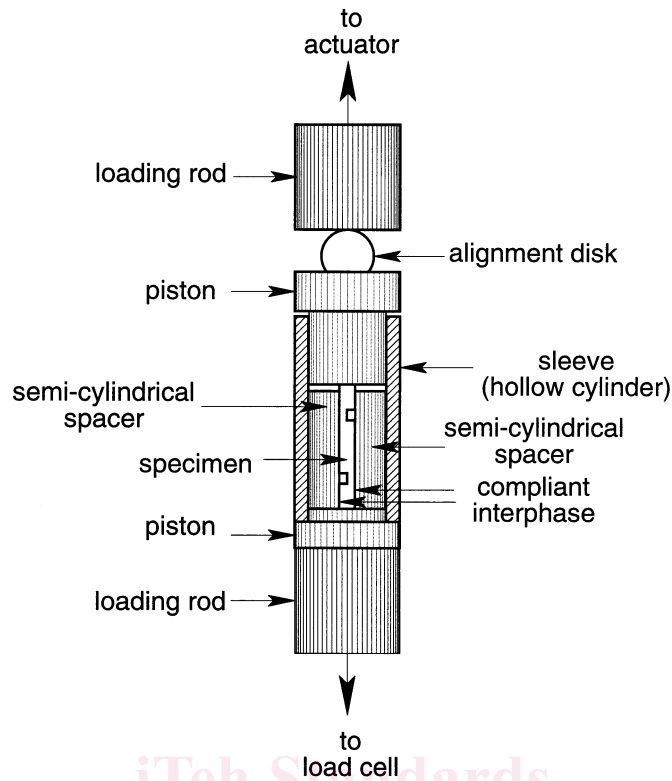
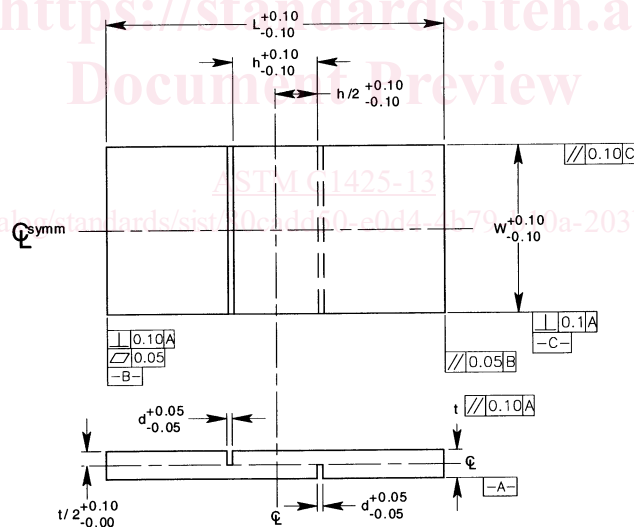

FIG. 3 Schematic of Test Fixture for the Compression of Double-Notched Test Specimens at Elevated Temperatures



NOTE 1—All tolerances are in millimetres. Refer to Table 1.

FIG. 4 Dimensions of Double-Notched Test Specimen

TABLE 1 Recommended Dimensions for Double-Notched Compression Test Specimen

Dimension	Description	Value, mm	Tolerance, mm
L	test specimen length	30.00	±0.10
h	distance between notches	6.00	±0.10
W	test specimen width	15.00	±0.10
d	notch width	0.50	±0.05
t	test specimen thickness	—	—

NOTE 3—Because many CFCCs are produced as flat plates and the outer surfaces may reflect the texture of the underlying fiber bundles, as-fabricated plates might not meet the parallelism requirements prescribed in Fig. 3 without additional machining of the test specimen faces. The faces of the test