



Designation: D2595 – 96 (Reapproved 2008)<sup>ε1</sup>

# Standard Test Method for Evaporation Loss of Lubricating Greases Over Wide- Temperature Range<sup>1</sup>

This standard is issued under the fixed designation D2595; the number immediately following the designation indicates the year of original adoption or, in the case of revision, the year of last revision. A number in parentheses indicates the year of last reapproval. A superscript epsilon ( $\epsilon$ ) indicates an editorial change since the last revision or reapproval.

*This standard has been approved for use by agencies of the U.S. Department of Defense.*

<sup>ε1</sup> NOTE—Removed outdated source of supply footnote from Section 6 editorially in April 2013.

## 1. Scope

1.1 This test method covers the determination of evaporation loss of lubricating greases at temperatures between 93 and 316°C (200 and 600°F). This test method is intended to augment Test Method D972, which is limited to 149°C (300°F).

1.2 The values stated in SI units are to be regarded as the standard. The values in parentheses are for information only.

1.3 *This standard does not purport to address all of the safety concerns, if any, associated with its use. It is the responsibility of the user of this standard to establish appropriate safety and health practices and determine the applicability of regulatory limitations prior to use.* For specific safety information, see 5.2.

## 2. Referenced Documents

2.1 *ASTM Standards:*<sup>2</sup>

A240/A240M Specification for Chromium and Chromium-Nickel Stainless Steel Plate, Sheet, and Strip for Pressure Vessels and for General Applications

D217 Test Methods for Cone Penetration of Lubricating Grease

D972 Test Method for Evaporation Loss of Lubricating Greases and Oils

E1 Specification for ASTM Liquid-in-Glass Thermometers

## 3. Terminology

3.1 *Definitions:*

<sup>1</sup> This test method is under the jurisdiction of ASTM Committee D02 on Petroleum Products and Lubricants and is the direct responsibility of Subcommittee D02.G0.03 on Physical Tests.

Current edition approved May 1, 2008. Published September 2008. Originally approved in 1967. Last previous edition approved in 2002 as D2595-96(2002)<sup>ε1</sup>. DOI: 10.1520/D2595-96R08.

<sup>2</sup> For referenced ASTM standards, visit the ASTM website, www.astm.org, or contact ASTM Customer Service at service@astm.org. For *Annual Book of ASTM Standards* volume information, refer to the standard's Document Summary page on the ASTM website.

3.1.1 *lubricating grease, n*—a semi-fluid to solid product of a thickener in a liquid lubricant.

3.1.1.1 *Discussion*—The dispersion of the thickener forms a two-phase system and immobilizes the liquid lubricant by surface tension and other physical forces. Other ingredients are commonly included to impart special properties. **D217**

3.1.2 *thickener, n*—a substance composed of finely-divided particles dispersed in a liquid to form the product's structure.

3.1.2.1 *Discussion*—Thickeners can be fibers (such as various metallic soaps) or plates or spheres (such as certain non-soap thickeners), which are insoluble or, at most, only very slightly soluble in the liquid lubricant. The general requirements are that the solid particles are extremely small, uniformly dispersed, and capable of forming a relatively stable, gel-like structure with the liquid lubricant. **D217**

## 4. Summary of Test Method

4.1 A weighed sample of grease in an evaporation cell is placed in a heating device maintained at the desired test temperature. Heated air is passed over the grease surface for 22 ± 0.1 h. The loss in weight of the sample due to evaporation is determined.

## 5. Significance and Use

5.1 The loss of volatile materials from greases and oils can adversely affect the original performance characteristics of a lubricant and, therefore, could be a significant factor in evaluating a lubricant for a specific use. Such volatiles can also be considered contaminants in the environment in which the lubricant is to be used. Correlation between results from this test method and service performance has not been established.

5.2 The test method can be used at any specified temperature between 93 and 316°C (200 and 600°F) that may be agreed upon by the user of the method. (**Warning**—This test method should not be used at temperatures which exceed the flash point of the base oil of the grease.)

NOTE 1—The specified flow of air, 2.58 ± 0.02 g/min, (2 L/min at standard temperature and pressure), assumes dry air. It is not known that the original work involved dry air but it has since been shown that this can

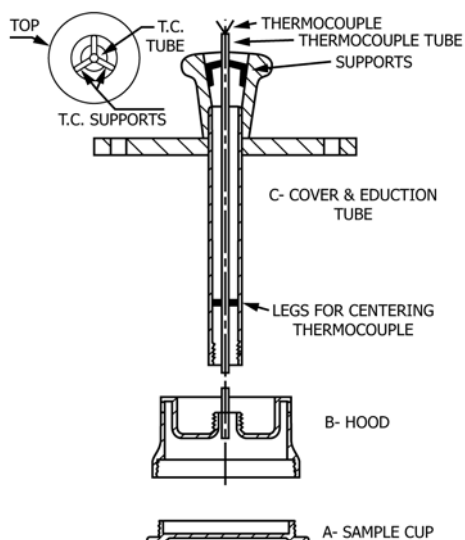
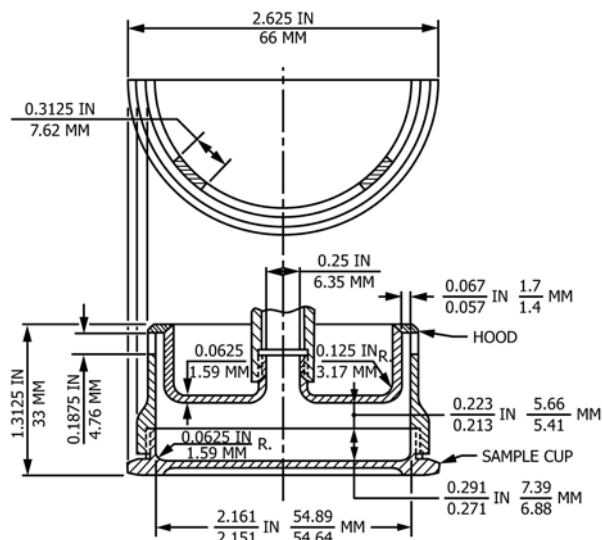

FIG. 1 Thermocouple Arrangement



SECTION OF GREASE SAMPLE CUP ALL DIMENSIONS  $\pm 0.0156$  in. ( $\pm 0.4$  mm) UNLESS OTHERWISE SPECIFIED

FIG. 2 Evaporation Test Cell

be a factor in reproducibility and should be addressed. Air with a dew point of less than 10°C at standard temperature and pressure will be satisfactory.

## 6. Apparatus

6.1 *Evaporation Cell Assembly* (Fig. 1) consisting of the following items:

6.1.1 *Sample Cup, A.*

6.1.2 *Hood, B.*

6.1.3 *Cover and Eduction Tube, C*—These items (5.1.1 to 5.1.3) shall be constructed from a stainless steel conforming to Type 304 of Specification A240/A240M. Design dimensions and dimensional tolerances shall be as shown in Fig. 2 and Fig. 3.

6.1.4 *Gasket*—Shall be of a heat-resistant (315°C (600°F)) material. A gasket cut from 3.2 mm (1/8-in.) TFE-fluorocarbon sheet has been found to work successfully.

6.1.5 *Thermocouple Tube and Supports*—The tube shall be of stainless steel having an outside diameter of  $3.18 \pm 0.025$  mm ( $0.125 \pm 0.001$  in.) and fitted with stainless steel centering devices as shown in Fig. 1.

6.2 *Air Supply System*—Shall consist of a calibrated flowmeter, filtering device, and accessory valves capable of delivering and maintaining a flow of dust-free air at the rate of  $2.58 \pm 0.02$  g/min between 15.6 and 29.4°C (60 and 85°F) (2 L/min at standard temperature and pressure).

6.3 *Heating Device*—An aluminum block heater similar to that shown in Fig. 4 has been found to be satisfactory. It is more fully described in Appendix X1.

6.4 *Thermometers*—ASTM thermometers graduated in either Fahrenheit or Celsius degrees and having a range from  $-5$  to 400°C (20 to 760°F) and conforming to the requirements for Thermometers 3C or 3F respectively as described in Specification E1.

## 7. Sampling

7.1 Each test will require approximately 20 g to fill the sample cup for a single run. Therefore, the sample presented

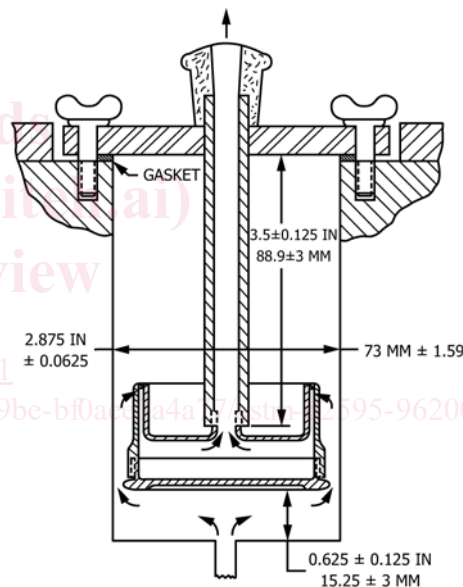

FIG. 3 Assembled Test Cell in Aluminum Block Heater

for analysis should be large enough to make possible the selection of a representative portion for testing. Examine the sample for any indication of non-homogeneity such as oil separation, phase changes, or gross contamination. If any abnormal conditions are found, obtain a new sample.

## 8. Preparation of Apparatus

8.1 Clean thoroughly all parts of the evaporation cell assembly.

8.2 With Fig. 1 as reference, connect the cover-eduction tube (C) to the hood (B). Adjust thermocouple tube so that the bottom of the tube is flush with face of hood as shown. Insert thermocouple in tube and adjust so that tip is flush with bottom edge of tube. Fasten the thermocouple securely in this position