



Designation: D3061 – 97 (Reapproved 2013)

Standard Guide for Three-Piece Steel and Tinplate Straight-Wall and Necked-In Aerosol Cans¹

This standard is issued under the fixed designation D3061; the number immediately following the designation indicates the year of original adoption or, in the case of revision, the year of last revision. A number in parentheses indicates the year of last reapproval. A superscript epsilon (ϵ) indicates an editorial change since the last revision or reapproval.

1. Scope

1.1 In the interest of uniformity and quality, the aerosol industry has developed dimensional guidelines which are suggested for U.S. three-piece steel and tin-plate aerosol cans of straight-wall and necked-in design. Domestic can makers uniformly agreed to comply with these guidelines and were instrumental in their development. A series of standard methods and gages were also developed to uniformly determine specific dimensions. The tolerances established for these dimensions allow for can manufacturing and filling process variations.

1.2 It is the purpose of this guide to provide a listing of currently manufactured aerosol can sizes as well as industry voluntary dimensional guidelines.

1.3 **Table 1** and **Table 2** present the sales code diameter and height of straight-wall and necked-in three-piece aerosol cans. The units in parentheses are in SI format, an alternate reference using dimensions suggested by the Metric Working Group of the Can Makers Institute. They are based on International Organization for Standardization (ISO) inside diameters to the nearest whole millimetre. Can heights are based on heights over the double seam (CSMA Dimension D) converted to the nearest whole millimetre.

1.4 The values stated in inch-pound units are to be regarded as standard. The values given in parentheses are mathematical conversions to SI units that are provided for information only and are not considered standard.

2. Terminology

2.1 Specific dimensions used in this guide are described as follows and correspond to those associated with the cross-sectional drawings of straight-wall and necked-in aerosol cans (**Fig. 1** and **Fig. 2**, respectively).

2.2 Dimensions and Definitions:

- 2.2.1 *A*—inside diameter of the 1-in. (25.4-mm) opening.
- 2.2.2 *B*—outside diameter of the 1-in. (25.4-mm) opening.
- 2.2.3 *C*—distance from the top of the curl of the 1-in. (25.4-mm) opening to the top of the top double seam.
- 2.2.4 *D*—distance from the top of the top double seam to the bottom of the bottom double seam.
- 2.2.5 *E*—distance from the top of the curl of the 1-in. (25.4-mm) opening to the bottom of the bottom double seam.
- 2.2.6 *F*—distance between the bottom of the top double seam and the top of the bottom double seam.
- 2.2.7 *G*—curl thickness of the 1-in. (25.4-mm) opening measured using the special Starrett micrometer or equivalent.
- 2.2.8 *J**—vertical distance from the maximum snap-lock diameter to the bottom of the countersink.
- 2.2.9 *K*—outside diameter of the top double seam (excluding crossover).
- 2.2.10 *L**—width of the countersink at the maximum snap-lock diameter.
- 2.2.11 *M**—snap-lock undertuck.
- 2.2.12 *N**—outside diameter of the snap-lock.
- 2.2.13 *P**—snap-lock wall length, as measured vertically from the maximum snap-lock diameter to the point of maximum undertuck.
- 2.2.14 *S*—vertical distance, tangent to the outside diameter of the dome double seam, from the top of the dome double seam to the necked-in area of the can sidewall.
- 2.2.15 *T*—width or height of the top double seam.
- 2.2.16 *V**—body outside diameter of necked-in cans.
- 2.2.17 *W*—top neck angle of the body wall.

NOTE 1—* Method of measurement to be agreed upon between the supplier and the user if needed.

3. Guideline Dimensions

3.1 The following tables provide guideline dimensions for straight-wall and necked-in three-piece aerosol cans (alternate tables furnish SI equivalents).

3.2 Various container heights (*D*, *E*, and *F*) are based on the following examples:

¹ This guide is under the jurisdiction of ASTM Committee D10 on Packaging and is the direct responsibility of Subcommittee D10.33 on Mechanical Dispensers. Originally developed by the Chemical Specialties Manufacturers Assn. (CSMA).

Current edition approved April 1, 2013. Published April 2013. Originally approved in 1972. Last previous edition approved in 2008 as D3061 – 97(2008). DOI: 10.1520/D3061-97R13.

TABLE 1 Sales Code Height for Various Diameters of Straight-Wall Aerosol Cans (SI)

202 (52 mm) by	207.5 (60 mm) by	211 (65 mm) by	300 (73 mm) by
214 (73)	509 (141)	413 (122)	709 (192)
306 (85)	605 (160)	600 (152)	
314 (98)	701 (179)	604 (158)	
406 (111)	703 (182)	612 (171)	
505 (134)	708 (190)	713 (198)	
509 (141)	713 (198)	908 (241)	
700 (177)			
708 (190)			

TABLE 2 Sales Code Height for Various Diameters of Necked-In Aerosol Cans (SI)

111/112 by (45 mm)	200/202 by (52 mm)	202/205 by (57 mm)	207.5/211 by (65 mm)	211/214 by (70 mm)
214 (73)	214 (73)	410 (117)	413 (122)	315 (100)
312 (95)	314 (98)	604 (158)	604 (158)	413 (122)
410 (117)	406 (111)	608 (165)	612 (171)	714 (200)
508 (139)	509 (141)	701 (179)	713 (198)	804 (209)
608 (165)	514 (149)	704 (184)		1006 (263)
	700 (177)	710 (193)		
	708 (190)	802 (206)		
		803 (207)		

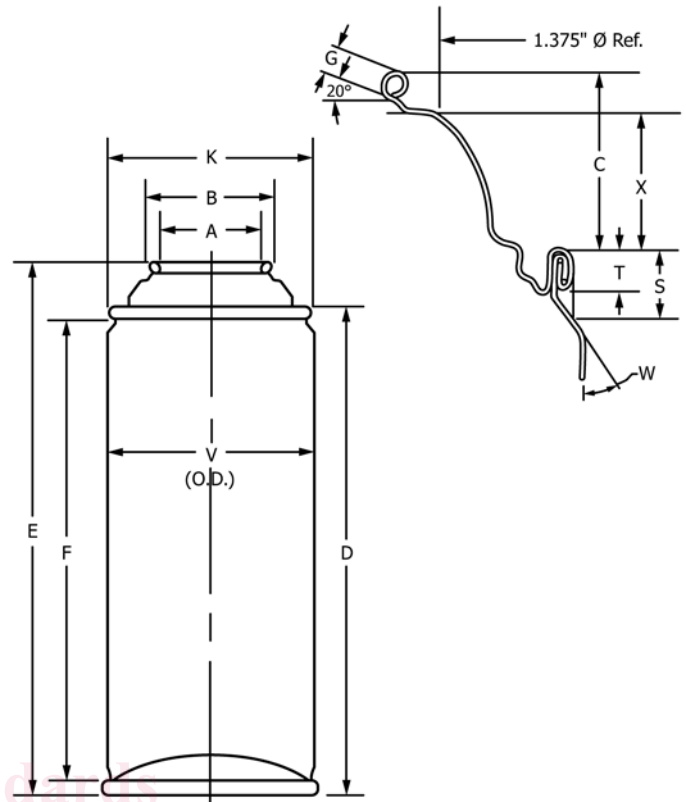

FIG. 2 Necked-In Aerosol Can

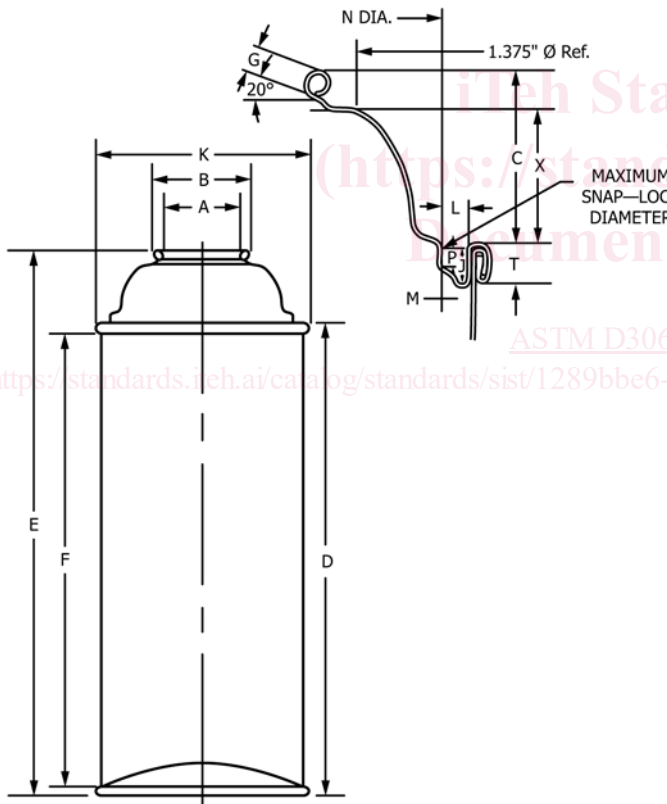

FIG. 1 Straight-Wall Aerosol Can

3.2.1 A typical 211 by 413 aerosol can has a Sales Code height of 413, or $4\frac{13}{16}$ in., which converted to its decimal equivalent, is 4.812 in.. However, Dimension *D* is derived by subtracting 0.020 in. from the decimal conversion of the Sales Code height:

$$D = 4.812 \text{ in.} - 0.020 \text{ in.} = 4.792 \text{ in.} \quad (1)$$

3.2.2 Dimension *E* is obtained by adding the *C* Dimension to the *D* Dimension. The *C* Dimension is found in Tables 3-6, depending on end diameter and unit of measure.

$$E = C + D = 0.798 \text{ in.} + 4.792 \text{ in.} = 5.590 \text{ in.} \quad (2)$$

3.2.3 Dimension *F* is the Sales Code height decimal equivalent minus 0.300 in.. This conversion includes the double seam width or height of both top and bottom double seams, as well as, the 0.020-in. height reduction from our *D* Dimension determination.

$$F = 4.812 \text{ in.} - 0.300 \text{ in.} = 4.512 \text{ in.} \quad (3)$$

3.3 In all tables, the guidelines refer to Fig. 1 and Fig. 2, which illustrate the dimensions. Table 3 and Table 4 give straight-wall aerosol can height and curl dimensions. Table 5 and Table 6 give comparable information for necked-in aerosol cans.

4. Overcap Fit Dimensions

4.1 Table 7 provides the dimensions of top end and body which are critical for overcap fit.

5. Keywords

5.1 aerosol cans; specifications for tin-plate aerosol cans; tin-plate aerosol cans

TABLE 3 Straight-Wall Aerosol Cans Guideline Dimensions (Inches)

Nominal Can Size	A ±0.004	B ±0.010	C ±0.016	D ±0.031	E ±0.035	F (minimum)	G ±0.007
202 by 214	1.000	1.221	0.396	2.855	3.251	2.575	0.130
202 by 306	1.000	1.221	0.396	3.355	3.751	3.075	0.130
202 by 314	1.000	1.221	0.396	3.855	4.251	3.575	0.130
202 by 406	1.000	1.221	0.396	4.355	4.751	4.075	0.130
202 by 505	1.000	1.221	0.396	5.293	5.689	5.013	0.130
202 by 509	1.000	1.221	0.396	5.542	5.938	5.262	0.130
202 by 700	1.000	1.221	0.396	6.980	7.376	6.700	0.130
202 by 709	1.000	1.221	0.396	7.480	7.876	7.200	0.130
207.5 by 509	1.000	1.221	0.798	5.542	6.341	5.262	0.130
207.5 by 605	1.000	1.221	0.798	6.292	7.090	6.012	0.130
207.5 by 701	1.000	1.221	0.798	7.042	7.840	6.676	0.130
207.5 by 703	1.000	1.221	0.798	7.168	7.966	6.888	0.130
207.5 by 708	1.000	1.221	0.798	7.480	8.278	7.200	0.130
207.5 by 713	1.000	1.221	0.798	7.792	8.590	7.512	0.130
211 by 413	1.000	1.221	0.798	4.792	5.590	4.512	0.130
211 by 600	1.000	1.221	0.798	5.980	6.778	5.700	0.130
211 by 604	1.000	1.221	0.798	6.230	7.028	5.950	0.130
211 by 612	1.000	1.221	0.798	6.730	7.528	6.450	0.130
211 by 713	1.000	1.221	0.798	7.792	8.590	7.512	0.130
211 by 908	1.000	1.221	0.798	9.480	10.278	9.200	0.130
300 by 709	1.000	1.221	0.798	7.542	8.340	7.262	0.130

TABLE 4 Straight-Wall Aerosol Cans Guideline Dimensions (Millimetres)

Nominal Can Size	A ±0.10	B ±0.25	C ±0.41	D ±0.79	E ±0.89	F (minimum)	G ±0.18
52 by 73	25.40	31.01	9.40	72.52	82.58	65.41	3.30
52 by 85	25.40	31.01	9.40	85.22	95.28	78.11	3.30
52 by 98	25.40	31.01	9.40	97.92	107.98	90.81	3.30
52 by 111	25.40	31.01	9.40	110.62	120.68	103.51	3.30
52 by 134	25.40	31.01	9.40	134.43	144.49	127.32	3.30
52 by 141	25.40	31.01	9.40	140.78	150.84	133.67	3.30
52 by 177	25.40	31.01	9.40	177.29	187.35	170.18	3.30
52 by 190	25.40	31.01	9.40	189.99	200.05	182.88	3.30
60 by 141	25.40	31.01	20.27	140.78	161.05	133.67	3.30
60 by 160	25.40	31.01	20.27	159.83	180.10	152.72	3.30
60 by 179	25.40	31.01	20.27	178.88	199.15	171.77	3.30
60 by 182	25.40	31.01	20.27	182.05	202.32	174.94	3.30
60 by 190	25.40	31.01	20.27	189.99	210.26	182.88	3.30
60 by 198	25.40	31.01	20.27	197.93	218.20	190.82	3.30
65 by 122	25.40	31.01	20.27	121.72	141.99	114.62	3.30
65 by 152	25.40	31.01	20.27	151.89	172.16	144.62	3.30
65 by 158	25.40	31.01	20.27	158.24	178.51	151.13	3.30
65 by 171	25.40	31.01	20.27	170.94	191.21	163.83	3.30
65 by 198	25.40	31.01	20.27	197.93	218.20	190.82	3.30
65 by 241	25.40	31.01	20.27	240.79	261.06	233.68	3.30
73 by 192	25.40	31.01	20.27	191.58	211.85	184.47	3.30