



Designation: **E2248–12 E2248 – 13**

Standard Test Method for Impact Testing of Miniaturized Charpy V-Notch Specimens¹

This standard is issued under the fixed designation E2248; the number immediately following the designation indicates the year of original adoption or, in the case of revision, the year of last revision. A number in parentheses indicates the year of last reappraisal. A superscript epsilon (ϵ) indicates an editorial change since the last revision or reappraisal.

1. Scope

1.1 This test method describes notched-bar impact testing of metallic materials using Miniaturized Charpy V-Notch (MCVN) specimens and test apparatus. It provides: (a) a description of the apparatus, (b) requirements for inspection and calibration, (c) safety precautions, (d) sampling, (e) dimensions and preparation of specimens, (f) testing procedures, and (g) precision and bias.

1.2 This standard concerns Miniaturized Charpy V-Notch specimens, for which all linear dimensions, including length and notch depth, are reduced with respect to a type A standard impact test specimen in accordance with Test Methods E23. These are not the same as sub-size specimens, described in Annex A3 of Test Methods E23, for which length, notch angle and notch depth are the same as for the standard type A Charpy specimen. See also 1.5 below.

1.3 Comparison of the MCVN data with conventional Charpy V-Notch (CVN) data or application of the MCVN data, or both, to the evaluation of ferritic material behavior is the responsibility of the user of this test method and is not explicitly covered by this test method.

1.4 The values stated in SI units are to be regarded as standard. No other units of measurement are included in this standard.

1.5 This standard does not address testing of sub-size specimens as discussed in Test Methods E23. The reader should understand the distinction between miniature and subsize. Miniature specimens are shorter than sub-size specimens so that more tests can be conducted per unit volume of material. Moreover, miniature specimens are designed so that the stress fields which control fracture are similar to those of conventional Test Methods E23 specimens.

1.6 The MCVN test may be performed using a typical Test Methods E23 test machine with suitably modified anvils and striker or using a smaller capacity machine.

1.7 *This standard does not purport to address all of the safety concerns, if any, associated with its use. It is the responsibility of the user of this standard to establish appropriate safety and health practices and determine the applicability of regulatory limitations prior to use.*

2. Referenced Documents

2.1 ASTM Standards:²

A370 Test Methods and Definitions for Mechanical Testing of Steel Products

E23 Test Methods for Notched Bar Impact Testing of Metallic Materials

E177 Practice for Use of the Terms Precision and Bias in ASTM Test Methods

E691 Practice for Conducting an Interlaboratory Study to Determine the Precision of a Test Method

E2298 Test Method for Instrumented Impact Testing of Metallic Materials

2.2 ISO Standards:³

ISO 148 Metallic materials -- Charpy pendulum impact test -- Part 1: Test method

ISO 14556 Steel -- Charpy V-notch pendulum impact test -- Instrumented test method

3. Summary of Test Method

3.1 The essential features of the MCVN impact test are: (a) a suitable miniature three point bend specimen, (b) anvils and supports on which the test specimen is placed to receive the blow of the moving mass, (c) a moving mass (striker) that has been

¹ This test method is under the jurisdiction of ASTM Committee E28 on Mechanical Testing and is the direct responsibility of Subcommittee E28.07 on Impact Testing. Current edition approved April 1, 2012/April 1, 2013. Published May 2012/April 2013. Originally approved in 2009. Last previous edition approved in 2009/2012 as E2248–09–12. DOI: 10.1520/E2248-12.10.1520/E2248-13.

² For referenced ASTM standards, visit the ASTM website, www.astm.org, or contact ASTM Customer Service at service@astm.org. For *Annual Book of ASTM Standards* volume information, refer to the standard's Document Summary page on the ASTM website.

³ Available from International Organization for Standardization (ISO), 1, ch. de la Voie-Creuse, Case postale 56, CH-1211, Geneva 20, Switzerland, http://www.iso.org.

released from a sufficient height to cause the mass to break the specimen placed in its path, (d) a device for determining the energy absorbed by the broken specimen, and optionally (e) instrumentation for measuring applied force as a function of time during specimen loading (refer to Test Method E2298).

3.2 The test consists of breaking the miniaturized specimen, notched in the middle, and supported at each end, with one blow from a swinging pendulum under conditions defined hereafter.

4. Significance and Use

4.1 There are cases where it is impractical or impossible to prepare conventional CVN specimens. MCVN specimens are an alternative approach for characterizing notched specimen impact behavior. Typical applications include MCVN specimens prepared from the broken halves of previously tested specimens, from thin product form material, or from material cut from in-service components.

4.2 This standard establishes the requirements for performing impact tests on MCVN specimens fabricated from metallic materials. Minimum requirements are given for measurement and recording equipment such that similar sensitivity and comparable measurements, as compared to conventional CVN tests, are achieved. The user should be aware that the transition region temperature dependence data obtained from MCVN specimens are not directly comparable to those obtained from full-size standard Charpy-V specimens and suitable correlation procedures have to be employed to obtain ductile-to-brittle transition temperature (DBTT) data equivalent to those obtained using CVN specimens. In all instances, correlations will have to be developed to relate upper shelf energy (USE) data from MCVN test to CVN comparable energy levels. Application of MCVN test data to the evaluation of ferritic material behavior is the responsibility of the user of this test method. MCVN test data should not be used directly to determine the lowest allowable operating temperature for an in-service material. The data must be interpreted within the framework of a fracture mechanics assessment.

4.3 While this ~~Test Method~~ test method treats the use of an instrumented striker as an option, the use of instrumentation in the impact test is recommended and is fully described in Test Method E2298. In order to establish the force-displacement diagram, it is necessary to measure the impact force as a function of time during contact of the striker with the specimen. The area under the force-displacement curve is a measure of absorbed energy. As an alternative, absorbed energy may be evaluated directly from machine dial reading. Whenever possible, an optical encoder shall be used in place of the machine dial because an encoder has better resolution than a dial.

5. Test Machine

5.1 The test shall be carried out with a pendulum-type impact testing machine which is (optionally) instrumented to determine force-time curves. The test machine shall have sufficient capacity to break the specimen in one blow while losing not more than 80 % of the initial potential energy. Provided energy measurements can be obtained with a resolution better than or equal to 0.1 J, the same test machine used for CVN testing may be used to test MCVN specimens.

5.2 The MCVN specimen has to be suitably supported so that the centerline of the specimen coincides with the center of strike of the pendulum. If the same machine used for CVN testing is used for MCVN specimens, refer to Appendix X3 of E23 for changing the specimen support height by manufacturing new supports or adding shims.

5.3 The impact velocity (tangential velocity) of the pendulum at the center of the strike shall not be less than 1 nor more than 6 m/s.

NOTE 1—Impact velocities above 4 m/s are not advisable for instrumented MCVN tests, since excessive oscillations are then superimposed on the initial portion of the test diagram and errors in the evaluation of the force-displacement trace may occur. For the same reason (ease of interpretation of the instrumented curve), lower velocities are allowed for MCVN tests than required by E23 (not less than 3 m/s).

5.4 It is recommended that the scalability of the stress fields is maintained. This is accomplished by scaling the striker radius, anvil radii, and the span of the anvils with respect to a specimen size that is proportional to the CVN specimen. Fig. 1 shows the dimensions of 8 and 2 mm strikers (3.86 mm and 0.96 mm) scaled for use with the nominal 1/2-scale MCVN (4.83 by 4.83 by 24.13 mm) specimen shown in Fig. 2. For both of these scaled strikers, the anvil radius is scaled to 0.48 $\text{mm} \pm 0.025 \text{ mm}$, and the span is 19.3 $\text{mm} \pm 0.025 \text{ mm}$.

5.5 A non-scaled 2 mm striker can be used to test the 4 by 3 by 27 mm MCVN specimen described in Annex D of ISO 14556. The anvil radius and span, in this case are 1 $\text{mm}^{+0.50}$ and 22 $\text{mm}^{+0.10}$ mm respectively.

NOTE 2—This particular test is allowed because a substantial amount of data exists for this specimen and test geometry. This MCVN specimen is not proportional to the CVN specimen, so scaling is not appropriate.

5.6 The testing machine shall be a pendulum type of rigid construction. All general requirements for apparatus and calibration specified in Test Methods E23 shall be satisfied.

5.7 For instrumented force measurements using optional force measuring instrumentation, the requirements given in Test Method E2298 regarding striker instrumentation, data acquisition, and data analysis shall be satisfied.

Miniaturized Charpy V-Notch Strikers

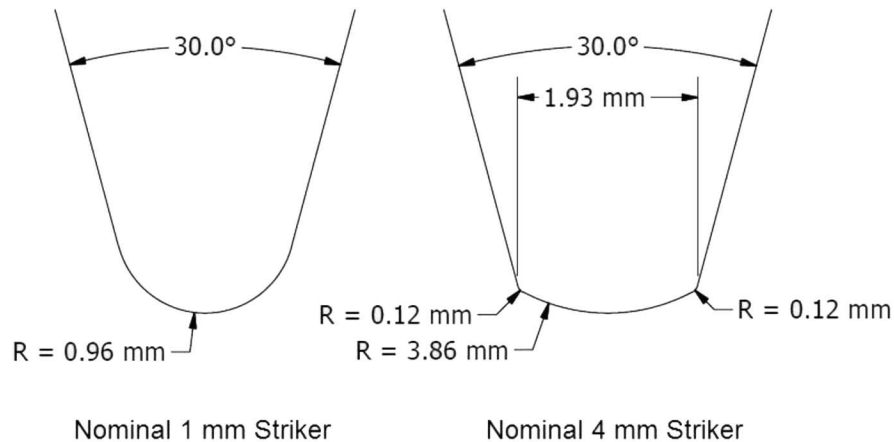
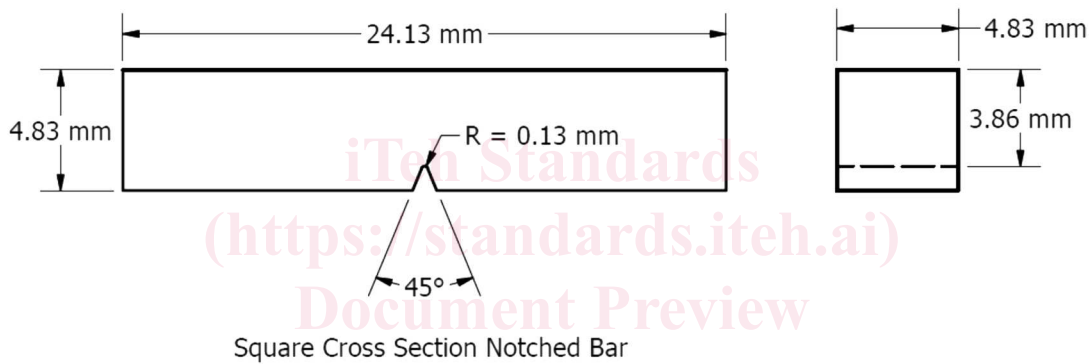

FIG. 1 Scaled 8 mm and 2 mm Strikers for Use in Miniaturized Charpy Impact Testing



Square Cross Section Notched Bar

NOTE 1—Permissible variations shall be as follows:

Angle of striker	$\pm 1^\circ$
Radius of curvature of striking edge	Nominal 1 mm Striker: $+0.25, -0$ Nominal 4 mm Striker: ± 0.025 mm
Radius of curvature of striking edge	Nominal 1 mm Striker: $+0.25, -0$ mm Nominal 4 mm Striker: ± 0.025 mm
Radius of shoulder of nominal 4 mm striker	± 0.025 mm
Width of edge of nominal 4 mm striker	± 0.025 mm
Surface finish requirements	$0.1\mu\text{m}$ or better
Notch length to edge	$90^\circ \pm 2^\circ$
Notch root radius	± 0.025 mm
Adjacent sides at	$90^\circ \pm 10$ min
Ligament length	± 0.025 mm
Cross section dimensions	± 0.025 mm
Finish requirements	$2\mu\text{m}$ notched surface/opposite surface $4\mu\text{m}$ other surfaces
Finish requirements	$2\mu\text{m}$ notched surface/opposite surface $4\mu\text{m}$ other surfaces
Length of specimen	$+0, -12$ mm
Length of specimen	$+0, -0.12$ mm
Centering of notch	± 0.12 mm
Angle of notch	$\pm 1^\circ$

FIG. 2 Nominal 1/2-Scale Miniaturized Charpy Impact Specimen

6. Hazards

6.1 Safety precautions should be taken to protect personnel from electric shock, the swinging pendulum, flying broken specimens, and hazards associated with specimen warming and cooling media. See also 1.6.