**Road vehicles — Communication
between vehicle and external
equipment for emissions-related
diagnostics —**

Part 3:

**Diagnostic connector and related
electrical circuits: Specification and
use**

*Véhicules routiers — Communications entre un véhicule et un
équipement externe pour le diagnostic relatif aux émissions —*

*Partie 3: Connecteur de diagnostic et circuits électriques associés:
spécifications et utilisation*

PROOF / ÉPREUVE



iTeh STANDARD PREVIEW (standards.iteh.ai)

ISO/PRF 15031-3

<https://standards.iteh.ai/catalog/standards/sist/df221ade-710a-4996-a888-c1bc872c7747/iso-prf-15031-3>



COPYRIGHT PROTECTED DOCUMENT

© ISO 2022

All rights reserved. Unless otherwise specified, or required in the context of its implementation, no part of this publication may be reproduced or utilized otherwise in any form or by any means, electronic or mechanical, including photocopying, or posting on the internet or an intranet, without prior written permission. Permission can be requested from either ISO at the address below or ISO's member body in the country of the requester.

ISO copyright office
CP 401 • Ch. de Blandonnet 8
CH-1214 Vernier, Geneva
Phone: +41 22 749 01 11
Email: copyright@iso.org
Website: www.iso.org

Published in Switzerland

Contents

	Page
Foreword.....	iv
Introduction.....	v
1 Scope.....	1
2 Normative references.....	1
3 Terms and definitions.....	1
4 Abbreviated terms.....	1
5 Conventions.....	2
6 Technical requirements overview.....	2
7 Physical layer.....	2
7.1 PM – Data link connector (DLC) requirements.....	2
7.1.1 PM – RHD vehicle DLC system performance requirements.....	2
7.1.2 PM – RHD vehicle DLC location and position.....	2
7.1.3 PM – RHD vehicle DLC securely mounted.....	2
7.1.4 PM – RHD vehicle DLC mounting direction and tolerance.....	2
7.2 PM – DLC Ethernet support layout.....	3
7.3 PM – ACL for on-board pyrotechnic devices.....	3
Bibliography.....	4

iTech STANDARD PREVIEW
(standards.iteh.ai)

[ISO/PRF 15031-3](https://standards.iteh.ai/catalog/standards/sist/df221ade-710a-4996-a888-c1bc872c7747/iso-prf-15031-3)

<https://standards.iteh.ai/catalog/standards/sist/df221ade-710a-4996-a888-c1bc872c7747/iso-prf-15031-3>

Foreword

ISO (the International Organization for Standardization) is a worldwide federation of national standards bodies (ISO member bodies). The work of preparing International Standards is normally carried out through ISO technical committees. Each member body interested in a subject for which a technical committee has been established has the right to be represented on that committee. International organizations, governmental and non-governmental, in liaison with ISO, also take part in the work. ISO collaborates closely with the International Electrotechnical Commission (IEC) on all matters of electrotechnical standardization.

The procedures used to develop this document and those intended for its further maintenance are described in the ISO/IEC Directives, Part 1. In particular, the different approval criteria needed for the different types of ISO documents should be noted. This document was drafted in accordance with the editorial rules of the ISO/IEC Directives, Part 2 (see www.iso.org/directives).

Attention is drawn to the possibility that some of the elements of this document may be the subject of patent rights. ISO shall not be held responsible for identifying any or all such patent rights. Details of any patent rights identified during the development of the document will be in the Introduction and/or on the ISO list of patent declarations received (see www.iso.org/patents).

Any trade name used in this document is information given for the convenience of users and does not constitute an endorsement.

For an explanation of the voluntary nature of standards, the meaning of ISO specific terms and expressions related to conformity assessment, as well as information about ISO's adherence to the World Trade Organization (WTO) principles in the Technical Barriers to Trade (TBT), see www.iso.org/iso/foreword.html.

This document was prepared by Technical Committee ISO/TC 22, *Road vehicles*, Subcommittee SC 31, *Data communication*.

This third edition cancels and replaces the second edition (ISO 15031-3:2016), which has been technically revised.

The main changes are as follows:

- restructuration of the document;
- introduction of requirement numbers, names and definitions;
- update of the dated references to SAE J1962:201607.

A list of all parts in the ISO 15031 series can be found on the ISO website.

Any feedback or questions on this document should be directed to the user's national standards body. A complete listing of these bodies can be found at www.iso.org/members.html.

Introduction

The ISO 15031 series consists of a number of parts which, taken together, provide a coherent self-consistent set of specifications to facilitate emissions-related diagnostics. ISO 15031-1 provides an overview about communication between vehicle and external equipment for emissions-related diagnostics. ISO 15031-2 through ISO 15031-7 are based on SAE recommended practices. This document is based on SAE J1962 (diagnostic connector).

The first edition of this document was based on SAE J1962 and was intended to meet European OBD requirements for 2000 and later model year vehicles, and added a modified connector type to accommodate vehicles with a 24 V system.

The ISO 15031 series includes the communication between the vehicle's on-board diagnostic (OBD) systems and test equipment implemented across vehicles within the scope of the legislated emissions-related OBD.

To achieve this, it is based on the Open Systems Interconnection (OSI) Basic Reference Model in accordance with ISO/IEC 7498-1 and ISO/IEC 10731:

- data link layer:
 - ISO 11898-1;
 - SAE J1850;
 - ISO 9141-2;
 - ISO 14230-2;
 - ISO 26021-1.
- physical layer:
 - ISO 11898-1, ISO 11898-2;
 - SAE J1850;
 - ISO 9141-2;
 - ISO 14230-1;
 - ISO 26021-1.

[Figure 1](#) illustrates this document's reference according to the OSI model.

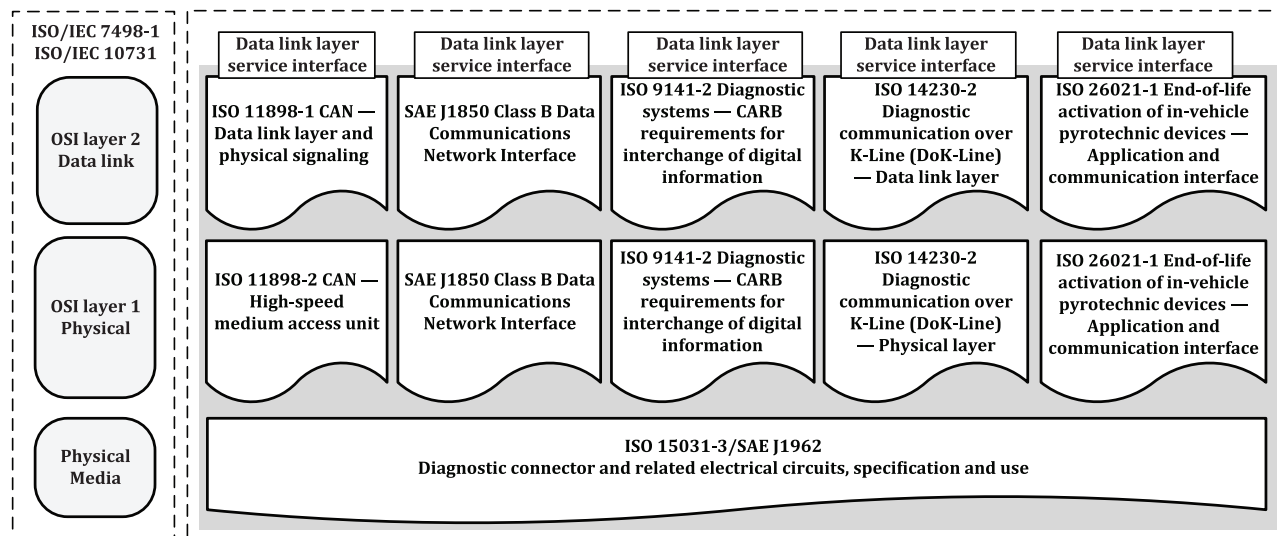

Figure 1 — ISO 15031-3 document reference according to OSI model

iTeh STANDARD PREVIEW
(standards.iteh.ai)

ISO/PRF 15031-3

<https://standards.iteh.ai/catalog/standards/sist/df221ade-710a-4996-a888-c1bc872c7747/iso-prf-15031-3>

Road vehicles — Communication between vehicle and external equipment for emissions-related diagnostics —

Part 3: Diagnostic connector and related electrical circuits: Specification and use

1 Scope

This document references the latest publication of SAE J1962.

On-board diagnostic (OBD) regulations require road vehicles to be equipped with a standardized connector for purposes of access to OBD information by ISO 15031-4 compliant external test equipment. This document describes the requirements for the physical connection and associated pin usage to allow for standard access to the OBD data.

This document is technically equivalent to SAE J1962 with the exception of the specific requirements identified and the specification of additional requirements related to right hand driven (RHD) vehicles.

2 Normative references

The following documents are referred to in the text in such a way that some or all of their content constitutes requirements of this document. For dated references, only the edition cited applies. For undated references, the latest edition of the referenced document (including any amendments) applies.

ISO 13400-4, *Road vehicles — Diagnostic communication over Internet Protocol (DoIP) — Part 4: Ethernet-based high-speed data link connector*

ISO 15031-2, *Road vehicles — Communication between vehicle and external equipment for emissions-related diagnostics — Part 2: Guidance on terms, definitions, abbreviations and acronyms*

ISO 26021-1, *Road vehicles — End-of-life activation of in-vehicle pyrotechnic devices — Part 1: Application and communication interface*

3 Terms and definitions

For the purposes of this document, the terms and definitions given in ISO 15031-2 apply.

ISO and IEC maintain terminology databases for use in standardization at the following addresses:

— ISO Online browsing platform: available at <https://www.iso.org/obp>

— IEC Electropedia: available at <https://www.electropedia.org/>

4 Abbreviated terms

ACL	additional communication line
CAN	controller area network
DLC	data link connector

PM physical media
 RHD right-hand-driven

5 Conventions

This document is based on OSI service conventions as specified in ISO/IEC 10731.

6 Technical requirements overview

[Table 1](#) provides an overview about technical requirements and associated requirement numbers.

Table 1 — Technical requirements overview

OSI#.REQ#	Technical requirement title
1	Physical layer
1.1	PM – RHD vehicle DLC system performance requirements
1.2	PM – RHD vehicle DLC location and position
1.3	PM – RHD vehicle DLC securely mounted
1.4	PM – RHD vehicle DLC mounting direction and tolerance
1.5	PM – Ethernet connector layout
1.6	PM – ACL for on-board pyrotechnic devices

7 Physical layer

7.1 PM – Data link connector (DLC) requirements

7.1.1 PM – RHD vehicle DLC system performance requirements

REQ	1.1 PM – RHD vehicle DLC system performance requirements
For RHD vehicles the performance requirement “It shall also withstand a force of 220 N applied in all other axial directions without mechanical failure.” as specified in SAE J1962:201607, 5.10.4 e) shall not apply.	

7.1.2 PM – RHD vehicle DLC location and position

This requirement replaces SAE J1962:201607, 4.1.1.

REQ	1.2 PM – RHD vehicle DLC location and position
The DLC of RHD vehicles shall have the connector located in the first-row foot well region.	

7.1.3 PM – RHD vehicle DLC securely mounted

REQ	1.3 PM – RHD vehicle DLC securely mounted
The DLC of RHD vehicles shall be securely mounted to the vehicle in order to facilitate mating and un-mating.	

7.1.4 PM – RHD vehicle DLC mounting direction and tolerance

REQ	1.4 PM – RHD vehicle DLC mounting direction and tolerance
The DLC of RHD vehicles shall be mounted such that the face of the vehicle connector is pointing downward (90° from horizontal, the -z direction) or toward the rear of the vehicle (0° from horizontal, the -x direction), or any angle in between (see SAE J1962:201607, Figure 2) with a tolerance of ±5°.	

The connector can be mounted vertically or horizontally, (see SAE J1962:201607, Figure 2), but may not be oriented in any other angles.

7.2 PM – DLC Ethernet support layout

The DLC Ethernet support layout allows pin-out option #1 and #2.

REQ	1.5 PM – DLC Ethernet support layout
The DLC support of Ethernet, including layout, pin-out information and simplified test equipment circuitry for Ethernet option #1 and #2 shall be in accordance with ISO 13400-4. Only one option shall be supported by the vehicle.	

7.3 PM – ACL for on-board pyrotechnic devices

The additional communication line for on-board pyrotechnic devices connector layout and pin-out information is specified in ISO 26021-1.

REQ	1.6 PM – ACL for on-board pyrotechnic devices
If the ACL in combination with support of ISO 9141-2 or ISO 14230-4 protocol for on-board pyrotechnic devices is supported on the vehicle's diagnostic connector, the ACL shall use the L line on pin 15 according to ISO 26021-1.	

iTeh STANDARD PREVIEW
(standards.iteh.ai)

[ISO/PRF 15031-3](https://standards.iteh.ai/catalog/standards/sist/df221ade-710a-4996-a888-c1bc872c7747/iso-prf-15031-3)

<https://standards.iteh.ai/catalog/standards/sist/df221ade-710a-4996-a888-c1bc872c7747/iso-prf-15031-3>

Bibliography

- [1] ISO/IEC/IEEE 8802-3, *Telecommunications and exchange between information technology systems — Requirements for local and metropolitan area networks — Part 3: Standard for Ethernet*
- [2] ISO/IEC 7498-1, *Information technology — Open Systems Interconnection — Basic Reference Model: The Basic Model*
- [3] ISO 9141-2, *Road vehicles — Diagnostic systems — Part 2: CARB requirements for interchange of digital information*
- [4] ISO/IEC 10731, *Information technology — Open Systems Interconnection — Basic Reference Model — Conventions for the definition of OSI services*
- [5] ISO 13400-3, *Road vehicles — Diagnostic communication over Internet Protocol (DoIP) — Part 3: Wired vehicle interface based on IEEE 802.3*
- [6] ISO 14230-4, *Road vehicles — Diagnostic systems — Keyword Protocol 2000 — Part 4: Requirements for emission-related systems*
- [7] ISO 15031-1, *Road vehicles — Communication between vehicle and external equipment for emissions-related diagnostics — Part 1: General information and use case definition*
- [8] ISO 15031-4, *Road vehicles — Communication between vehicle and external equipment for emissions-related diagnostics — Part 4: External test equipment*
- [9] ISO 15765-4, *Road vehicles — Diagnostic communication over Controller Area Network (DoCAN) — Part 4: Requirements for emissions-related systems*
- [10] SAE J1850, *Class B Data Communications Network Interface*
- [11] SAE J1962:201607, *Diagnostic Connector*