



**International  
Standard**

**ISO 813-2**

**Rubber, vulcanized or  
thermoplastic — Determination of  
adhesion to a rigid substrate —**

**Part 2:  
Adhesion of a soft thermoplastic  
elastomer layer**

*Caoutchouc vulcanisé ou thermoplastique — Détermination de  
l'adhérence à un substrat rigide —*

*Partie 2: Adhérence d'une couche d'élastomère thermoplastique  
souple*

**First edition  
2024-02**

iTeh Standards  
(<https://standards.iteh.ai>)  
Document Preview

[ISO 813-2:2024](https://standards.iteh.ai/catalog/standards/iso/1c25ec5c-3587-4416-af20-a46f65840db2/iso-813-2-2024)

<https://standards.iteh.ai/catalog/standards/iso/1c25ec5c-3587-4416-af20-a46f65840db2/iso-813-2-2024>



**COPYRIGHT PROTECTED DOCUMENT**

© ISO 2024

All rights reserved. Unless otherwise specified, or required in the context of its implementation, no part of this publication may be reproduced or utilized otherwise in any form or by any means, electronic or mechanical, including photocopying, or posting on the internet or an intranet, without prior written permission. Permission can be requested from either ISO at the address below or ISO's member body in the country of the requester.

ISO copyright office  
CP 401 • Ch. de Blandonnet 8  
CH-1214 Vernier, Geneva  
Phone: +41 22 749 01 11  
Email: [copyright@iso.org](mailto:copyright@iso.org)  
Website: [www.iso.org](http://www.iso.org)

Published in Switzerland

# Contents

	Page
<b>Foreword</b> .....	<b>iv</b>
<b>Introduction</b> .....	<b>v</b>
<b>1 Scope</b> .....	<b>1</b>
<b>2 Normative references</b> .....	<b>1</b>
<b>3 Terms and definitions</b> .....	<b>1</b>
<b>4 Principle</b> .....	<b>2</b>
<b>5 Apparatus</b> .....	<b>2</b>
5.1 Tensile testing machine.....	2
5.2 Test trolley.....	2
<b>6 Calibration</b> .....	<b>3</b>
<b>7 Test pieces</b> .....	<b>3</b>
7.1 Form and dimensions.....	3
7.2 Test piece fabrication using the injection moulding method.....	4
7.3 Test piece with inserted rigid substrate.....	5
7.4 Number of test pieces.....	5
<b>8 Conditioning</b> .....	<b>5</b>
<b>9 Test conditions</b> .....	<b>6</b>
<b>10 Procedure</b> .....	<b>6</b>
<b>11 Expression of results</b> .....	<b>6</b>
11.1 Peel strength.....	6
11.2 Fracture pattern.....	7
<b>12 Test report</b> .....	<b>8</b>
<b>Annex A (informative) Example of listing the test results</b> .....	<b>10</b>
<b>Annex B (normative) Calibration schedule</b> .....	<b>12</b>
<b>Annex C (informative) Glossary</b> .....	<b>14</b>
<b>Bibliography</b> .....	<b>15</b>

## Foreword

ISO (the International Organization for Standardization) is a worldwide federation of national standards bodies (ISO member bodies). The work of preparing International Standards is normally carried out through ISO technical committees. Each member body interested in a subject for which a technical committee has been established has the right to be represented on that committee. International organizations, governmental and non-governmental, in liaison with ISO, also take part in the work. ISO collaborates closely with the International Electrotechnical Commission (IEC) on all matters of electrotechnical standardization.

The procedures used to develop this document and those intended for its further maintenance are described in the ISO/IEC Directives, Part 1. In particular, the different approval criteria needed for the different types of ISO document should be noted. This document was drafted in accordance with the editorial rules of the ISO/IEC Directives, Part 2 (see [www.iso.org/directives](http://www.iso.org/directives)).

ISO draws attention to the possibility that the implementation of this document may involve the use of (a) patent(s). ISO takes no position concerning the evidence, validity or applicability of any claimed patent rights in respect thereof. As of the date of publication of this document, ISO had not received notice of (a) patent(s) which may be required to implement this document. However, implementers are cautioned that this may not represent the latest information, which may be obtained from the patent database available at [www.iso.org/patents](http://www.iso.org/patents). ISO shall not be held responsible for identifying any or all such patent rights.

Any trade name used in this document is information given for the convenience of users and does not constitute an endorsement.

For an explanation of the voluntary nature of standards, the meaning of ISO specific terms and expressions related to conformity assessment, as well as information about ISO's adherence to the World Trade Organization (WTO) principles in the Technical Barriers to Trade (TBT), see [www.iso.org/iso/foreword.html](http://www.iso.org/iso/foreword.html).

This document was prepared by Technical Committee ISO/TC 45, *Rubber and rubber products*, Subcommittee SC 2, *Testing and analysis*.

A list of all parts in the ISO 813 series can be found on the ISO website.

Any feedback or questions on this document should be directed to the user's national standards body. A complete listing of these bodies can be found at [www.iso.org/members.html](http://www.iso.org/members.html).

<https://standards.iteh.ai/catalog/standards/iso/1c25ec5c-3587-4416-af20-a46f65840db2/iso-813-2-2024>

## Introduction

Nowadays it is common to use combinations of materials aimed at achieving special properties for parts of a product. Thermoplastic elastomers (TPEs) are used in a large percentage of these applications for functional, visual, acoustic, haptic and tactile reasons, with injection moulding used as the joining method in the majority of cases.<sup>[3,4]</sup> Due to their thermoplastic nature, TPE materials are gaining importance steadily in this area relative to vulcanized rubber.

Due to the wide variety of TPE types encountered nowadays and the large number of manufacturers, it is difficult to reach comparative conclusions regarding the bond strength between two materials. Accordingly, the purpose of this document is to specify a peel test procedure specifically for measuring the adhesion of a TPE to a rigid substrate.

iTeh Standards  
(<https://standards.iteh.ai>)  
Document Preview

[ISO 813-2:2024](https://standards.iteh.ai/catalog/standards/iso/1c25ec5c-3587-4416-af20-a46f65840db2/iso-813-2-2024)

<https://standards.iteh.ai/catalog/standards/iso/1c25ec5c-3587-4416-af20-a46f65840db2/iso-813-2-2024>



# Rubber, vulcanized or thermoplastic — Determination of adhesion to a rigid substrate —

## Part 2: Adhesion of a soft thermoplastic elastomer layer

**WARNING 1** — Persons using this document should be familiar with normal laboratory practice. This document does not purport to address all of the safety problems, if any, associated with its use. It is the responsibility of the user to establish appropriate safety and health practices and to determine the applicability of any other restrictions.

**WARNING 2** — Certain procedures specified in this document can involve the use or generation of substances, or the generation of waste, that could constitute a local environmental hazard. Reference should be made to appropriate documentation on safe handling and disposal after use.

### 1 Scope

This document specifies a test method for assessing the peel strength of a thermoplastic elastomer (TPE) to a rigid substrate. It is mainly applicable to soft components in the Shore A hardness range.

This document specifies a test piece but not the injection moulding tool for its manufacture. Hence, it is possible that different results are obtained for test pieces produced using different injection moulding tools.

### 2 Normative references

The following documents are referred to in the text in such a way that some or all of their content constitutes requirements of this document. For dated references, only the edition cited applies. For undated references, the latest edition of the referenced document (including any amendments) applies.

ISO 5893, *Rubber and plastics test equipment — Tensile, flexural and compression types (constant rate of traverse) — Specification*

ISO 6133, *Rubber and plastics — Analysis of multi-peak traces obtained in determinations of tear strength and adhesion strength*

ISO 18899:2013, *Rubber — Guide to the calibration of test equipment*

ISO 23529, *Rubber — General procedures for preparing and conditioning test pieces for physical test methods*

### 3 Terms and definitions

No terms and definitions are listed in this document.

ISO and IEC maintain terminology databases for use in standardization at the following addresses:

- ISO Online browsing platform: available at <https://www.iso.org/obp>
- IEC Electropedia: available at <https://www.electropedia.org/>

## 4 Principle

The force required to cause separation of a strip of a TPE covering a rigid substrate is measured, the angle of separation being 90° and the width and thickness of the TPE being fixed within specified limits.

Special TPE material descriptions are listed in [Annex C](#) for better understanding.

## 5 Apparatus

### 5.1 Tensile testing machine

A tensile testing machine in accordance with class 1 of ISO 5893 shall be used to perform the peel test.

### 5.2 Test trolley

An example of a suitable test trolley used for clamping the test piece is shown in [Figure 1](#) and the clamping arrangement in [Figure 2](#). The trolley mounting shall be such that the force required to set the test trolley, including the guide pulley, in motion in the horizontal direction does not exceed 4 N.

All dimensions are just a guide. The chosen dimension of the test specimen shall fit securely into the trolley.

Dimensions in millimetres

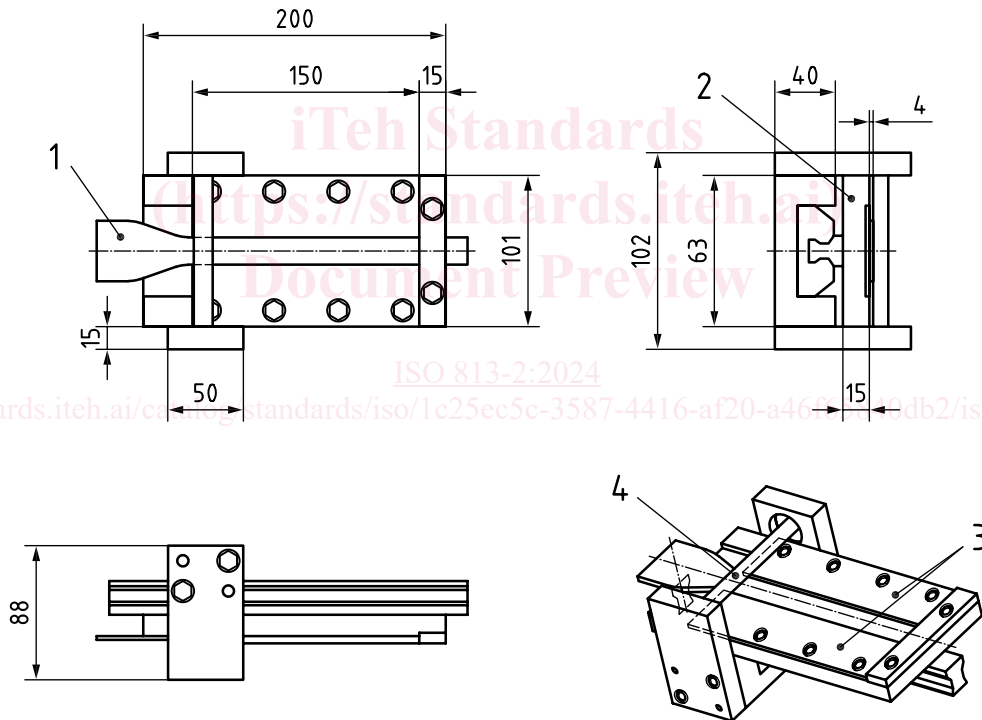

#### Key

- 1 clamped test specimen
- 2 mounting
- 3 clamping plates
- 4 guide pulley, free rotation shall be possible, a diameter of 8 mm to 9 mm is recommended

Figure 1 — Test trolley

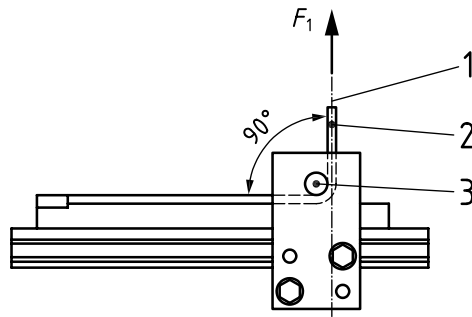

**Key**

- 1 tensile axis
- 2 free end of the soft component
- 3 guide pulley
- $F_1$  direction of the force the soft component is pulled from the rigid substrate

**Figure 2 — The test piece clamping arrangement**

## 6 Calibration

The test apparatus shall be calibrated in accordance with the schedule given in [Annex B](#).

## 7 Test pieces

### 7.1 Form and dimensions

The test piece shown in [Figure 3](#) shall be used. The standard wall thickness for the soft component shall be  $(2 \pm 0,2)$  mm, but in the case of a TPE with a low hardness, the soft component's wall thickness can be increased to  $(3 \pm 0,2)$  mm.

ISO 813-2:2024

<https://standards.iteh.ai/catalog/standards/iso/1c25ec5c-3587-4416-af20-a46f65840db2/iso-813-2-2024>

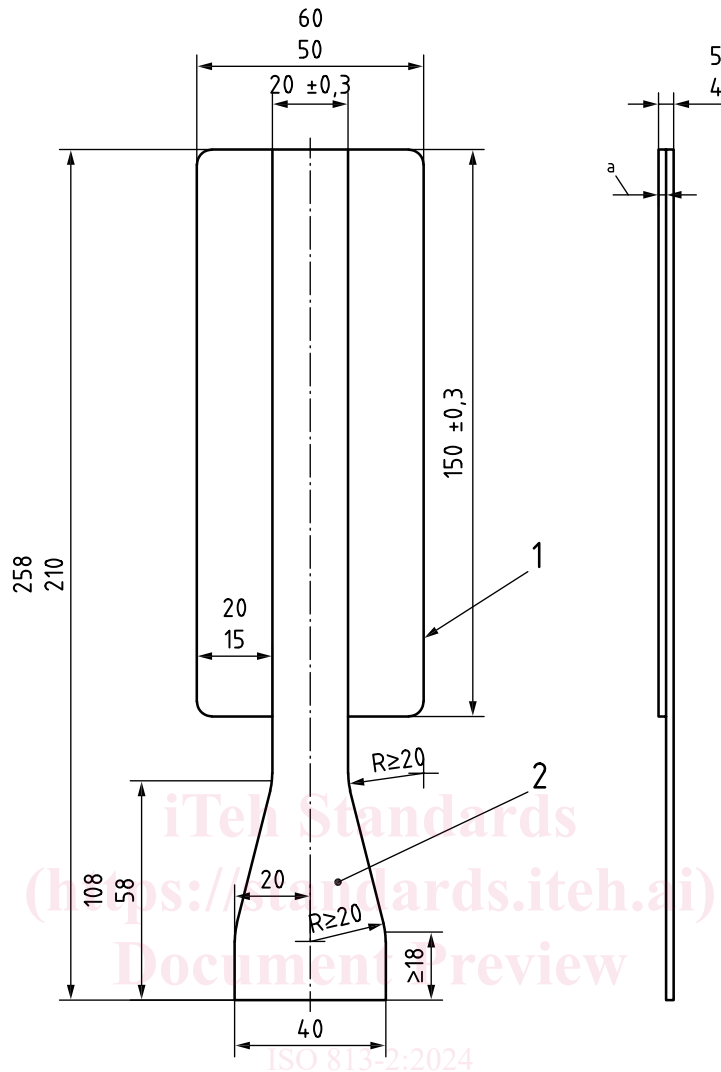

- Key**
- 1 rigid substrate
  - 2 soft component
  - a  $2-3 \pm 0,2$

Figure 3 — Test piece

## 7.2 Test piece fabrication using the injection moulding method

The test pieces shall preferably be fabricated using a two-component injection moulding method in accordance with the material manufacturer's processing instructions. The recommended technique is the core-back technique.<sup>[4]</sup> The tool's surface in the region of the subsequent bond for the pre-moulded hard component shall have a surface roughness of RA ranging from 2,20 µm to 3,20 µm according to ISO 21920-1, created by eroding the surface. The sequence of events in the moulding process shall proceed without interruption.

All the surfaces of the test piece should be free from visible defects such as flow marks, sink marks and air inclusions. Overmoulding at the interface region of the materials used should be avoided as far as possible. No overmoulding shall be present at the hard component's end face (strap-side). Possibly, a means of compensating for shrinking of the hard component will be necessary. The tool design shall exclude the formation of a weld line on the hard component. Note the examples of defects shown in [Figure 4](#).