

ISO /FDIS 283:2022(E)

ISO/TC 41/SC 3

Secretariat: SAC

Textile conveyor belts — Full thickness tensile strength, elongation at break and elongation at the reference load — Test method

Courroies transporteuses à carcasse textile — Résistance à la traction, allongement à la rupture et allongement sous force de référence en pleine épaisseur — Méthode d'essai

- Style Definition:** Heading 1: Indent: Left: 0 cm, First line: 0 cm, Tab stops: Not at 0.76 cm
- Style Definition:** Heading 2: Font: Bold, Tab stops: Not at 0.63 cm
- Style Definition:** Heading 3: Font: Bold
- Style Definition:** Heading 4: Font: Bold
- Style Definition:** Heading 5: Font: Bold
- Style Definition:** Heading 6: Font: Bold
- Style Definition:** ANNEX
- Style Definition:** AMEND Terms Heading: Font: Bold
- Style Definition:** AMEND Heading 1 Unnumbered: Font: Bold
- Formatted:** Font: Cambria, French (Switzerland)
- Formatted:** Adjust space between Latin and Asian text, Adjust space between Asian text and numbers
- Formatted:** Font: Bold, French (Switzerland)
- Formatted:** French (Switzerland)
- Formatted:** Font: Bold, French (Switzerland)
- Formatted:** French (Switzerland)
- Formatted:** Font: Bold
- Formatted:** Font: Bold, Not Italic

iTeh STANDARD PREVIEW

(standards.iteh.ai)

FDIS stage

ISO/FDIS 283

<https://standards.iteh.ai/catalog/standards/sist/c8b30e06-241f-4338-bbe2-b0d3fabfa008/iso-fdis-283>

© ISO 2022

All rights reserved. Unless otherwise specified, or required in the context of its implementation, no part of this publication may be reproduced or utilized otherwise in any form or by any means, electronic or mechanical, including photocopying, or posting on the internet or an intranet, without prior written permission. Permission can be requested from either ISO at the address below or ISO's member body in the country of the requester.

ISO Copyright Office

CP 401 • CH-1214 Vernier, Geneva

Phone: + 41 22 749 01 11

Email: copyright@iso.org

Website: www.iso.org

Published in Switzerland.

Formatted

iTeh STANDARD PREVIEW
(standards.iteh.ai)

ISO/FDIS 283

<https://standards.iteh.ai/catalog/standards/sist/c8b30e06-241f-4338-bbe2-b0d3fabfa008/iso-fdis-283>

Contents	Page
Foreword	5
1 Scope	1
2 Normative references	1
3 Terms and definitions	1
4 Principle.....	2
5 Apparatus	2
6 Test pieces.....	4
6.1 Shape and dimensions	4
6.2 Method of selection of test pieces	4
6.3 Preparation of test pieces.....	9
6.4 Number of test pieces.....	10
6.5 Conditioning of test pieces	10
7 Procedure.....	10
8 Calculation and expression of results	10
8.1 Tensile strength	10
8.2 Elongation	10
9 Test report	11
Bibliography	13
Foreword	5
1 Scope	1
2 Normative references	1
3 Terms and definitions.....	1
4 Principle.....	2
5 Apparatus	2
6 Test pieces.....	4
6.1 Shape and dimensions	4
6.2 Method of selection of test pieces	4
6.3 Preparation of test pieces.....	9
6.4 Number of test pieces.....	10
6.5 Conditioning of test pieces	10

7	Procedure	10
8	Calculation and expression of results	10
8.1	Tensile strength	10
8.2	Elongation	10
8.2.1	Elongation at break	10
8.2.2	Elongation at reference force (see 3.5)	11
9	Test report	11
	Bibliography	13

iTeh STANDARD PREVIEW
(standards.iteh.ai)

ISO/FDIS 283

<https://standards.iteh.ai/catalog/standards/sist/c8b30e06-241f-4338-bbe2-b0d3fabfa008/iso-fdis-283>

Foreword

ISO (the International Organization for Standardization) is a worldwide federation of national standards bodies (ISO member bodies). The work of preparing International Standards is normally carried out through ISO technical committees. Each member body interested in a subject for which a technical committee has been established has the right to be represented on that committee. International organizations, governmental and non-governmental, in liaison with ISO, also take part in the work. ISO collaborates closely with the International Electrotechnical Commission (IEC) on all matters of electrotechnical standardization.

The procedures used to develop this document and those intended for its further maintenance are described in the ISO/IEC Directives, Part 1. In particular, the different approval criteria needed for the different types of ISO documents should be noted. This document was drafted in accordance with the editorial rules of the ISO/IEC Directives, Part 2 (see www.iso.org/directives).

Attention is drawn to the possibility that some of the elements of this document may be the subject of patent rights. ISO shall not be held responsible for identifying any or all such patent rights. Details of any patent rights identified during the development of the document will be in the Introduction and/or on the ISO list of patent declarations received (see www.iso.org/patents).

Any trade name used in this document is information given for the convenience of users and does not constitute an endorsement.

For an explanation of the voluntary nature of standards, the meaning of ISO specific terms and expressions related to conformity assessment, as well as information about ISO's adherence to the World Trade Organization (WTO) principles in the Technical Barriers to Trade (TBT), see www.iso.org/iso/foreword.html.

This document was prepared by Technical Committee ISO/TC 41, *Pulleys and belts (including veebelts)*, Subcommittee SC 3, *Conveyor belts*, in collaboration with the European Committee for Standardization (CEN) Technical Committee CEN/TC 188, *Conveyor belts*, in accordance with the Agreement on technical cooperation between ISO and CEN (Vienna Agreement).

This fifth edition cancels and replaces the fourth edition (ISO 283:2015), which has been technically revised.

The main changes are as follows:

- addition of conditioning period requirement before being sampled in 6.1~~+~~_i
- clarification of sample width measuring point in 6.3~~+~~_i
- addition of cover reduction requirement in the grip areas in 6.3~~+~~_i
- deletion of the humidity requirement in 6.5.

Any feedback or questions on this document should be directed to the user's national standards body. A complete listing of these bodies can be found at www.iso.org/members.html.

Formatted: English (United Kingdom)

Formatted: Don't adjust space between Latin and Asian text, Don't adjust space between Asian text and numbers

Formatted: English (United Kingdom)

Formatted: English (United Kingdom)

Formatted: English (United Kingdom)

Formatted: English (United Kingdom)

Formatted: English (United Kingdom)

Formatted: English (United Kingdom)

Formatted: Font: Not Italic, English (United Kingdom)

Formatted: English (United Kingdom)

Formatted: Font: Not Italic, English (United Kingdom)

Formatted: English (United Kingdom)

Formatted: Font: Not Italic, English (United Kingdom)

Formatted: English (United Kingdom)

Formatted: English (United Kingdom)

Formatted: English (United Kingdom)

Formatted: Don't keep with next, Don't adjust space between Latin and Asian text, Don't adjust space between Asian text and numbers

Formatted: Font: Cambria, English (United Kingdom)

Formatted: List Continue 1, No bullets or numbering, Don't adjust space between Latin and Asian text, Don't adjust space between Asian text and numbers, Tab stops: 0.7 cm, Left + 1.4 cm, Left + 2.1 cm, Left + 2.8 cm, Left + 3.5 cm, Left + 4.2 cm, Left + 4.9 cm, Left + 5.6 cm, Left + 6.3 cm, Left + 7 cm, Left

Formatted: cite_sec

Formatted: cite_sec

Formatted: Font: Cambria

Formatted: cite_sec, Font: Cambria

Formatted: Font: Cambria

Formatted: Font: Cambria

Formatted: cite_sec, Font: Cambria

Formatted: Font: Cambria

Formatted: English (United Kingdom)

Formatted: Don't adjust space between Latin and Asian text, Don't adjust space between Asian text and numbers

Formatted: English (United Kingdom)

Textile conveyor belts — Full thickness tensile strength, elongation at break and elongation at the reference load — Test method

1 Scope

This document specifies a test method for the determination of the full thickness tensile strength in the longitudinal direction and the elongation at the reference force and breaking point of conveyor belts having a textile carcass. The method can also be used for the determination of full thickness tensile strength in the transverse direction and the elongation at the breaking point, for use when the manufacturer is requested by the purchaser to state values for these properties.

This document does not apply to light conveyor belts as described in ISO 21183-1.

2 Normative references

The following documents are referred to in the text in such a way that some or all of their content constitutes requirements of this document. For dated references, only the edition cited applies. For undated references, the latest edition of the referenced document (including any amendments) applies.

ISO 7500-1, *Metallic materials — Calibration and verification of static uniaxial testing machines — Part-1: Tension/compression testing machines — Calibration and verification of the force-measuring system*

ISO 18573, *Conveyor belts — Test atmospheres and conditioning periods*

3 Terms and definitions

For the purposes of this document, the following terms and definitions apply.

ISO and IEC maintain terminology databases for use in standardization at the following addresses:

ISO Online browsing platform: available at <https://www.iso.org/obp>

IEC Electropedia: available at <https://www.electropedia.org/>

3.1

tensile strength

greatest measured force during the tensile test divided by the width of the test piece

Note 1 to entry: It is expressed in N/mm.

3.2

nominal tensile strength

specified minimum value of the belt *tensile strength* (3.1)

Note 1 to entry: It is expressed in N/mm.

3.3

reference force

reference load

Formatted: Font: Cambria

Formatted: Font: Cambria

Formatted: Don't adjust space between Latin and Asian text, Don't adjust space between Asian text and numbers

Formatted: Don't adjust space between Latin and Asian text, Don't adjust space between Asian text and numbers

Formatted: English (United Kingdom)

Formatted: Font: Cambria, 11 pt, English (United Kingdom)

Formatted: No underline, Font color: Auto, English (United Kingdom)

Formatted: Don't adjust space between Latin and Asian text, Don't adjust space between Asian text and numbers, Tab stops: 0.7 cm, Left + 1.4 cm, Left + 2.1 cm, Left + 2.8 cm, Left + 3.5 cm, Left + 4.2 cm, Left + 4.9 cm, Left + 5.6 cm, Left + 6.3 cm, Left + 7 cm, Left

Formatted: English (United Kingdom)

Formatted: Default Paragraph Font, English (United Kingdom)

Formatted: No underline, Font color: Auto, English (United Kingdom)

Formatted: English (United Kingdom)

Formatted: Default Paragraph Font, English (United Kingdom)

Formatted: cite_sec

Formatted: Term(s), Don't adjust space between Latin and Asian text, Don't adjust space between Asian text and numbers

ISO/FDIS 283:2022(E)

one-tenth of the *nominal tensile strength* (3.2) in the longitudinal direction multiplied by the width of the test piece in millimetres

Formatted: cite_sec

EXAMPLE Nominal tensile strength = 1 600 N/mm; one tenth of the nominal tensile strength = 160 N/mm; reference force for 25 mm test piece = 25 mm × 160 N/mm = 4 000 N.

Note 1 to entry: It is expressed in N/mm.

3.4 elongation at break elongation at the greatest force

Note 1 to entry: It is expressed as the percentage increase in the distance between two reference points.

3.5 elongation at the reference force elongation at the reference load

elongation in the longitudinal direction at the reference force (load)

Note 1 to entry: It is expressed as the percentage increase in the distance between two reference points.

4 Principle

A test piece, cut from the full thickness of the conveyor belt, is extended under specified conditions using a tensile testing machine, until rupture of the test piece occurs.

5 Apparatus

The usual laboratory apparatus and, in particular, the following shall be used.

5.1 Tensile testing machine, of CRE or CRT type, calibrated to Grade 1 according to ISO 7500-1 and capable of extending the test piece at a constant rate, without interruption, of (100 ± 10) mm/min.

5.2 Device, such as an extensometer, with a measuring length of at least 100 mm and accurate to within 0,1 mm or better, capable of measuring the elongation of the gauge length marked on the test piece. Use of a device that produces a graphical trace throughout the test is preferred.

5.3 Grips, the form of which should prevent any slippage of the test piece during the tensile test. The use of grips with transverse serrations in accordance with Figure 1 is recommended.

Dimensions in millimetres

Formatted: Body Text, Tab stops: Not at 0.7 cm + 1.4 cm + 2.1 cm + 2.8 cm + 3.5 cm + 4.2 cm + 4.9 cm + 5.6 cm + 6.3 cm + 7 cm

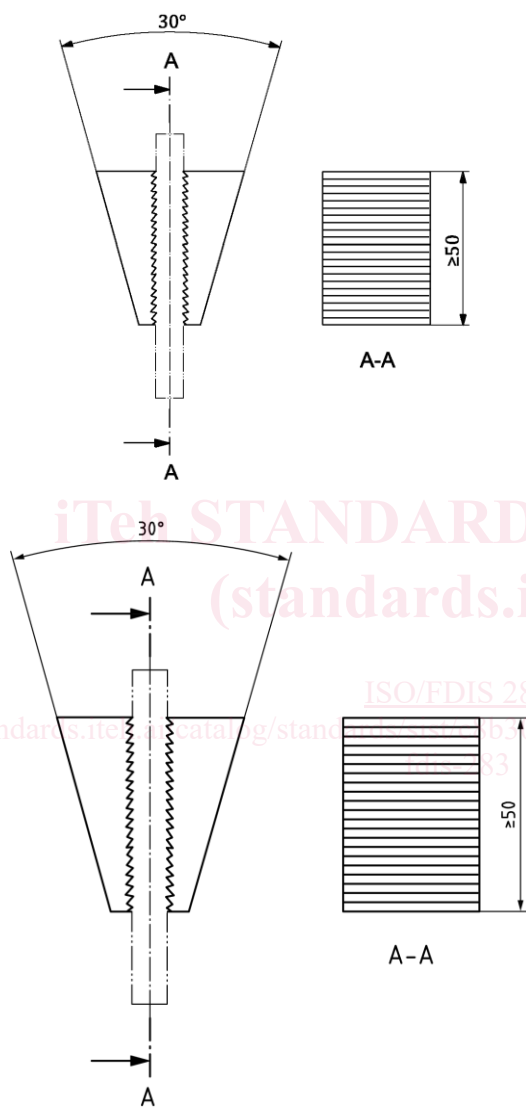

Figure 1 — Grip with transverse serrations

5.4 Die cutter or power saw, either of the dies with wall profiles as shown in Figure 2 being suitable for cutting the test pieces shown in Figure 3, Figure 4, and Figure 5. Other profiles may be used, but the critical feature is that the cut sides of the test piece are perpendicular to the test piece surfaces.

Formatted: Don't keep with next

6 Test pieces

6.1 Shape and dimensions

The shape and dimensions of the test piece shall be in accordance with Figure 3, Figure 4, Figure 5, or Figure 6.

6.2 Method of selection of test pieces

The specimen shall be sampled at least 24-hours after manufacture of the belt with any shorter time period to be noted. Test pieces shall be selected parallel, or at right angles, to the axis of the belt, and at not less than 50 mm from the edge of the belt. If test pieces are selected from a sample cut from the belt, no test piece shall be cut with its longitudinal edge less than 12 mm from the edge of the sample. In all cases, the cut or sawn sides of the test piece shall be perpendicular to its surface. No test piece shall contain a ply joint.

For a test piece of type D, draw the form of the test piece on the surface of the belt or sample and from each edge of the sample, cut at five places with a power saw up to the drawn lines (see Figure 6).

The type D test piece illustrated in Figure 6 should be limited to the testing of conveyor belts having tensile strengths greater than 2 000 N/mm.

Dimensions in millimetres

