

FINAL
DRAFT

INTERNATIONAL
STANDARD

ISO/FDIS
583

ISO/TC 41/SC 3

Secretariat: SAC

Voting begins on:
2022-12-01

Voting terminates on:
2023-01-26

Conveyor belts with a textile carcass — Total belt thickness and thickness of constitutive elements — Test methods

*Courroies transporteuses à carcasse textile — Épaisseur totale de la
courroie et épaisseur des éléments constitutifs — Méthodes d'essai*

iTeh STANDARD PREVIEW
(standards.iteh.ai)

ISO/FDIS 583

<https://standards.iteh.ai/catalog/standards/sist/3b008261-6c93-4996-9b0c-0742c0cfa3df/iso-fdis-583>

ISO/CEN PARALLEL PROCESSING

RECIPIENTS OF THIS DRAFT ARE INVITED TO SUBMIT, WITH THEIR COMMENTS, NOTIFICATION OF ANY RELEVANT PATENT RIGHTS OF WHICH THEY ARE AWARE AND TO PROVIDE SUPPORTING DOCUMENTATION.

IN ADDITION TO THEIR EVALUATION AS BEING ACCEPTABLE FOR INDUSTRIAL, TECHNOLOGICAL, COMMERCIAL AND USER PURPOSES, DRAFT INTERNATIONAL STANDARDS MAY ON OCCASION HAVE TO BE CONSIDERED IN THE LIGHT OF THEIR POTENTIAL TO BECOME STANDARDS TO WHICH REFERENCE MAY BE MADE IN NATIONAL REGULATIONS.



Reference number
ISO/FDIS 583:2022(E)

© ISO 2022

iTeh STANDARD PREVIEW
(standards.iteh.ai)

ISO/FDIS 583

<https://standards.iteh.ai/catalog/standards/sist/3b008261-6c93-4996-9b0c-0742c0cfa3df/iso-fdis-583>



COPYRIGHT PROTECTED DOCUMENT

© ISO 2022

All rights reserved. Unless otherwise specified, or required in the context of its implementation, no part of this publication may be reproduced or utilized otherwise in any form or by any means, electronic or mechanical, including photocopying, or posting on the internet or an intranet, without prior written permission. Permission can be requested from either ISO at the address below or ISO's member body in the country of the requester.

ISO copyright office
CP 401 • Ch. de Blandonnet 8
CH-1214 Vernier, Geneva
Phone: +41 22 749 01 11
Email: copyright@iso.org
Website: www.iso.org

Published in Switzerland

Contents

	Page
Foreword	iv
1 Scope	1
2 Normative references	1
3 Terms and definitions	1
4 Determination of total belt thickness	1
4.1 Apparatus.....	1
4.2 Test piece.....	1
4.3 Measurement points.....	2
4.4 Procedure.....	3
4.5 Expression of results.....	3
5 Determination of thickness of covers	3
5.1 General.....	3
5.2 Method used when covers can be removed completely from carcass.....	3
5.2.1 Principle.....	3
5.2.2 Apparatus.....	3
5.2.3 Test piece.....	3
5.2.4 Measurement points.....	3
5.2.5 Procedure.....	3
5.2.6 Expression of results.....	4
5.3 Method used when covers cannot be removed completely from carcass.....	5
5.3.1 Principle.....	5
5.3.2 Apparatus.....	5
5.3.3 Test piece.....	5
5.3.4 Measurement points.....	5
5.3.5 Procedure.....	5
5.3.6 Expression of results.....	6
6 Determination of carcass thickness	6
6.1 Carcass thickness without covers.....	6
6.2 Carcass thickness with covers.....	6
6.3 Expression of results.....	6
7 Determination of thickness of interlayer	7
7.1 General.....	7
7.2 Method used when elastomeric material in interlayer can be removed completely from adjacent fabric ply.....	7
7.2.1 Principle.....	7
7.2.2 Apparatus.....	7
7.2.3 Test piece.....	7
7.2.4 Measurement points.....	7
7.2.5 Procedure.....	7
7.2.6 Expression of results.....	7
7.3 Method for use when elastomeric material in interlayer cannot be separated completely from adjacent fabric ply.....	8
7.3.1 Principle.....	8
7.3.2 Apparatus.....	8
7.3.3 Test piece.....	8
7.3.4 Measurement points.....	8
7.3.5 Procedure.....	8
7.3.6 Expression of results.....	8
8 Test report	8
Bibliography	10

Foreword

ISO (the International Organization for Standardization) is a worldwide federation of national standards bodies (ISO member bodies). The work of preparing International Standards is normally carried out through ISO technical committees. Each member body interested in a subject for which a technical committee has been established has the right to be represented on that committee. International organizations, governmental and non-governmental, in liaison with ISO, also take part in the work. ISO collaborates closely with the International Electrotechnical Commission (IEC) on all matters of electrotechnical standardization.

The procedures used to develop this document and those intended for its further maintenance are described in the ISO/IEC Directives, Part 1. In particular, the different approval criteria needed for the different types of ISO documents should be noted. This document was drafted in accordance with the editorial rules of the ISO/IEC Directives, Part 2 (see www.iso.org/directives).

Attention is drawn to the possibility that some of the elements of this document may be the subject of patent rights. ISO shall not be held responsible for identifying any or all such patent rights. Details of any patent rights identified during the development of the document will be in the Introduction and/or on the ISO list of patent declarations received (see www.iso.org/patents).

Any trade name used in this document is information given for the convenience of users and does not constitute an endorsement.

For an explanation of the voluntary nature of standards, the meaning of ISO specific terms and expressions related to conformity assessment, as well as information about ISO's adherence to the World Trade Organization (WTO) principles in the Technical Barriers to Trade (TBT), see www.iso.org/iso/foreword.html.

This document was prepared by Technical Committee ISO/TC 41, *Pulleys and belts (including veebelts)*, Subcommittee SC 3, *Conveyor belts*, in collaboration with the European Committee for Standardization (CEN) Technical Committee CEN/TC 188, *Conveyor belts* in accordance with the Agreement on technical cooperation between ISO and CEN (Vienna Agreement).

This fourth edition cancels and replaces the third edition (ISO 583:2007), which has been technically revised.

The main changes are as follows:

- a requirement was added regarding the expression of results (see 4.5).

Any feedback or questions on this document should be directed to the user's national standards body. A complete listing of these bodies can be found at www.iso.org/members.html.

Conveyor belts with a textile carcass — Total belt thickness and thickness of constitutive elements — Test methods

1 Scope

This document specifies test methods for the determination of total belt thickness and the thickness of constitutive elements of conveyor belts having a textile carcass. The constitutive elements include the covers, the carcass and interlayers, i.e. the material between adjoining plies.

This document does not apply to light conveyor belts as described in ISO 21183-1^[1].

2 Normative references

There are no normative references in this document.

3 Terms and definitions

No terms and definitions are listed in this document.

ISO and IEC maintain terminology databases for use in standardization at the following addresses:

- ISO Online browsing platform: available at <https://www.iso.org/obp>
- IEC Electropedia: available at <https://www.electropedia.org/>

4 Determination of total belt thickness

4.1 Apparatus

The apparatus shall consist of a flat, rigid baseplate, on which the test piece rests, and a gauge having a flat circular foot, 10 mm in diameter, by means of which a specified pressure is applied to the test piece.

The gauge shall be capable of measuring to at least 0,1 mm.

The pressure applied shall be (22 ± 5) kPa for materials with a hardness equal to or greater than 35 IRHD; otherwise, the pressure shall be (10 ± 2) kPa.

NOTE The masses needed to give these specified pressures using a 10 mm diameter foot are 176 g and 80 g, respectively.

4.2 Test piece

Either test piece 1 or test piece 2, according to the following, shall be used.

Test piece 1: cut a rectangular piece of full-width belt, designated as dimension L , with a length of 50 mm, as shown in [Figure 1](#).

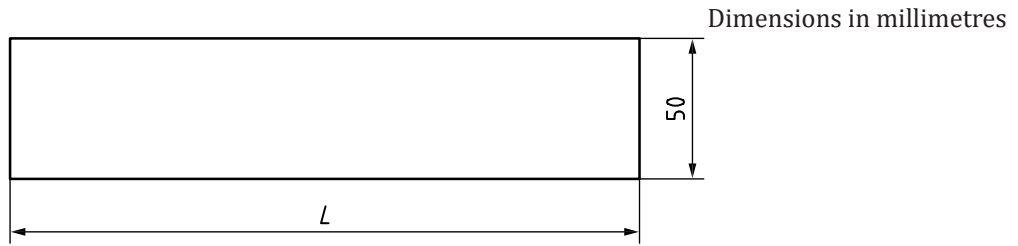

Figure 1 — Test piece 1 (rectangular)

Test piece 2: cut a wedge-shaped piece of full-width belt, designated as dimension L , as shown in [Figure 2](#).

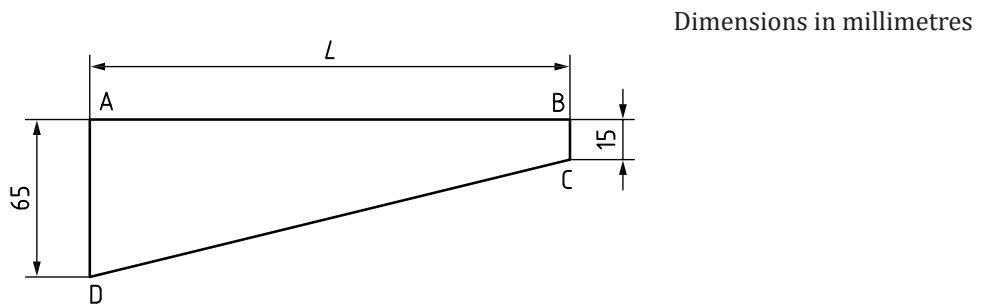

Figure 2 — Test piece 2 (wedge-shaped)

4.3 Measurement points

The measurement points shall be spaced equidistantly along the long axis of the test piece (i.e. the belt width), as shown in [Figure 3](#).

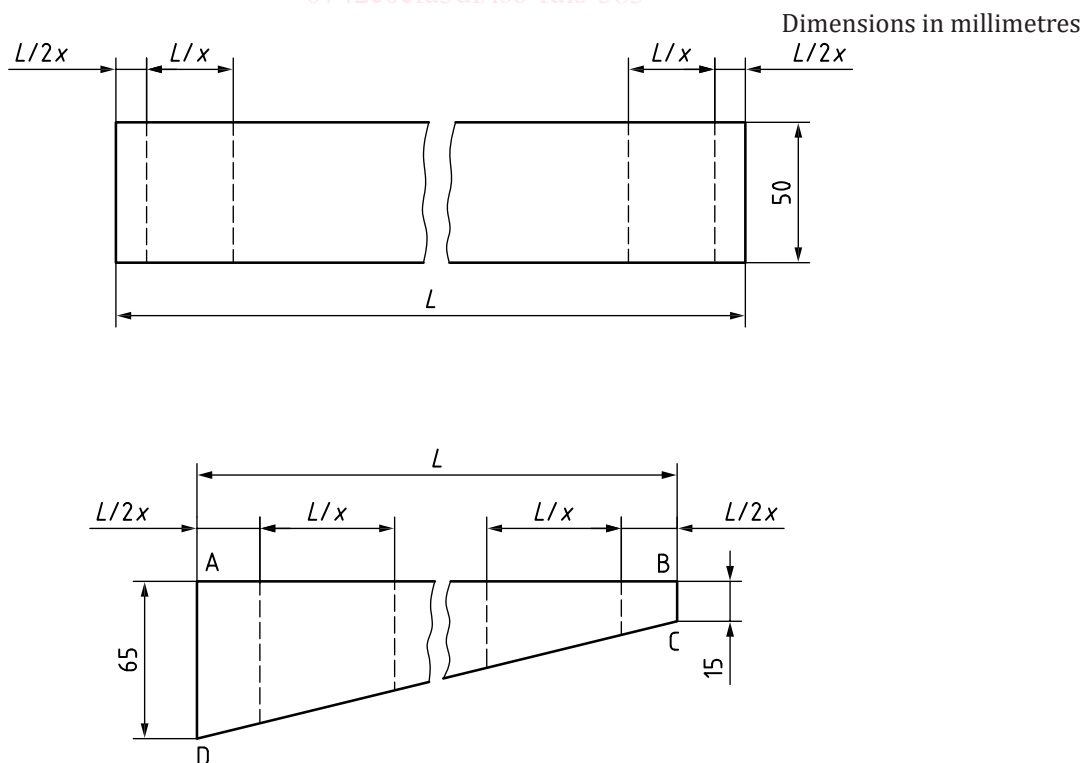

Figure 3 — Measurement points

Determine the minimum number of measurement points, x , according to the width of the belt, L , in accordance with [Table 1](#).

Table 1 — Minimum number of measurement points

Belt width L mm	Minimum number of measurement points x
$L \leq 650$	3
$650 < L \leq 1\,200$	5
$L > 1\,200$	8

4.4 Procedure

Measure the total thickness, d , of the test piece at each of the measurement points specified in [4.3](#), using the pressure specified in [4.1](#).

4.5 Expression of results

Calculate the arithmetic mean and the difference between the maximum thickness and the minimum thickness of the individual measurements taken according to [4.4](#).

Express the arithmetic mean as the total belt thickness in millimetres, to the nearest 0,1 mm.

5 Determination of thickness of covers

5.1 General

The thickness of the covers can be obtained by two methods, the choice of one or the other method depends on whether or not the covers can be removed completely from the carcass.

5.2 Method used when covers can be removed completely from carcass

5.2.1 Principle

The thickness of a test piece is measured at a number of points, according to belt width, both before and after each of the covers has been removed. The cover thickness is calculated by subtraction.

5.2.2 Apparatus

The apparatus shall be in accordance with [4.1](#).

5.2.3 Test piece

Test piece 1, in accordance with [4.2](#) and [Figure 1](#), shall be used.

5.2.4 Measurement points

The measurement points shall be in accordance with [4.3](#).

5.2.5 Procedure

Measure the total thickness, d , of the test piece at each of the measurement points, in accordance with [4.4](#).

Remove the top cover completely, then remeasure the thickness of the test piece, d_1 , at the same measurement points.

Then remove the bottom cover completely and measure the thickness of the test piece, d_2 , at the same measurement points.

See [Figure 4](#).

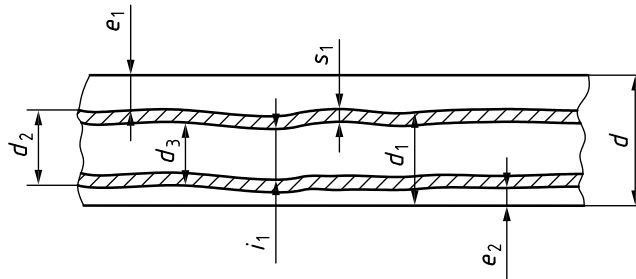

Key

- d total thickness
- d_1 thickness of test piece with top cover removed
- d_2 thickness of test piece with top and bottom covers removed
- d_3 thickness of test piece with one fabric ply removed ^a
- e_1 thickness of top cover
- e_2 thickness of bottom cover
- i_1 thickness of interlayer ^a
- s_1 thickness of fabric ^a
- ^a Applicable to belts with two fabric plies (see [7.2.5](#) and [7.2.6](#)).

Figure 4 — Interlayer thickness (plied fabric belt)

Protective fabrics embedded in the covers, and which do not form an integral part of the textile carcass, shall be regarded as part of the covers and should be removed with them. Other non-load bearing yarns, which are an integral part of the carcass, shall be regarded as part of the carcass, unless otherwise agreed between manufacturer and purchaser. In the latter case, full details shall be included in the test report.

5.2.6 Expression of results

Calculate the thickness, e_1 , of the top cover at each of the measurement points as given in [Formula \(1\)](#):

$$e_1 = d - d_1 \tag{1}$$

Calculate the thickness, e_2 , of the bottom cover at each of the measurement points as given in [Formula \(2\)](#):

$$e_2 = d_1 - d_2 \tag{2}$$

where

- d is the total belt thickness;
- d_1 is the thickness of the test piece with the top cover removed;
- d_2 is the thickness of the test piece with both top and bottom covers removed.

Calculate the arithmetic mean of the individual measurements and express the cover thicknesses in millimetres, to the nearest 0,1 mm.

5.3 Method used when covers cannot be removed completely from carcass

5.3.1 Principle

The thickness of each cover is measured directly on a cut edge of unstripped belt by means of an optical micrometer or travelling microscope.

5.3.2 Apparatus

Optical micrometer or travelling microscope incorporating a scale graduated in divisions of 0,1 mm shall be used.

5.3.3 Test piece

Cut the test piece in accordance with 4.2 (test piece 1 or test piece 2). If the conveyor belt is of solid woven construction, test piece 2 shall be used.

5.3.4 Measurement points

The measurement points shall be in accordance with 4.3. If test piece 2 is used, take measurements along line DC shown in [Figure 2](#).

5.3.5 Procedure

Using the optical micrometer or travelling microscope (5.3.2), measure the distance between the surface of the belting and the top of the nearest fabric knuckle (see [Figure 5](#)) at each of the measurement points specified in 4.3. Ensure that the graduated scale of the optical micrometer or travelling microscope is in physical contact with the test piece to avoid errors of parallax.

With certain colours of cover material, difficulty can be experienced in determining the outline of the fabric knuckles. In these cases, the textile fabric may be identified with a colour stain.

Protective fabrics embedded in the covers, and which do not form an integral part of the textile carcass, shall be regarded as part of the covers and excluded from the measurements. Other non-load bearing yarns, which are an integral part of the carcass, shall be regarded as part of the carcass, unless otherwise agreed between manufacturer and purchaser. In the latter case, full details shall be included in the test report.

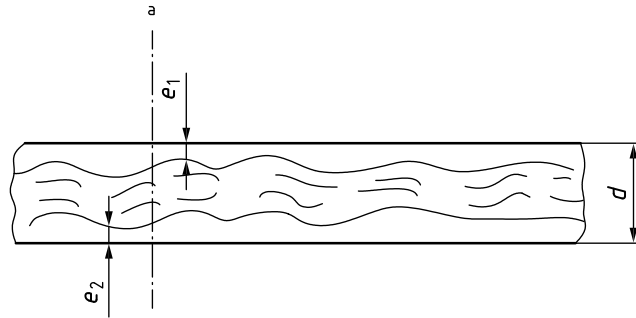

Key

- d total thickness
- e_1 thickness of top cover
- e_2 thickness of bottom cover
- a Target measurement point.

Figure 5 — Cover thickness (solid woven belt)

5.3.6 Expression of results

Calculate the arithmetic mean of the individual measurements for each cover and report the result in millimetres, to the nearest 0,1 mm, as e_1 , the thickness of the top cover, and e_2 , the thickness of the bottom cover.

6 Determination of carcass thickness

6.1 Carcass thickness without covers

For belts where the covers can be removed completely, measure the carcass thickness, d_2 , in accordance with 5.2.

6.2 Carcass thickness with covers

For belts where the covers cannot be removed, obtain the carcass thickness by subtracting the thickness of both covers, measured in accordance with 5.3, from the total belt thickness measured in accordance with Clause 4.

6.3 Expression of results

Calculate carcass thickness d_2 at each of the measurement points as given in Formula (3):

$$d_2 = d - (e_1 + e_2) \tag{3}$$

where

- d is the total belt thickness;
- e_1 is the thickness of the top cover;
- e_2 is the thickness of the bottom cover.

Calculate the arithmetic mean of the individual measurements and express carcass thickness d_2 in millimetres, to the nearest 0,1 mm.